

October 17, 2012

# standards

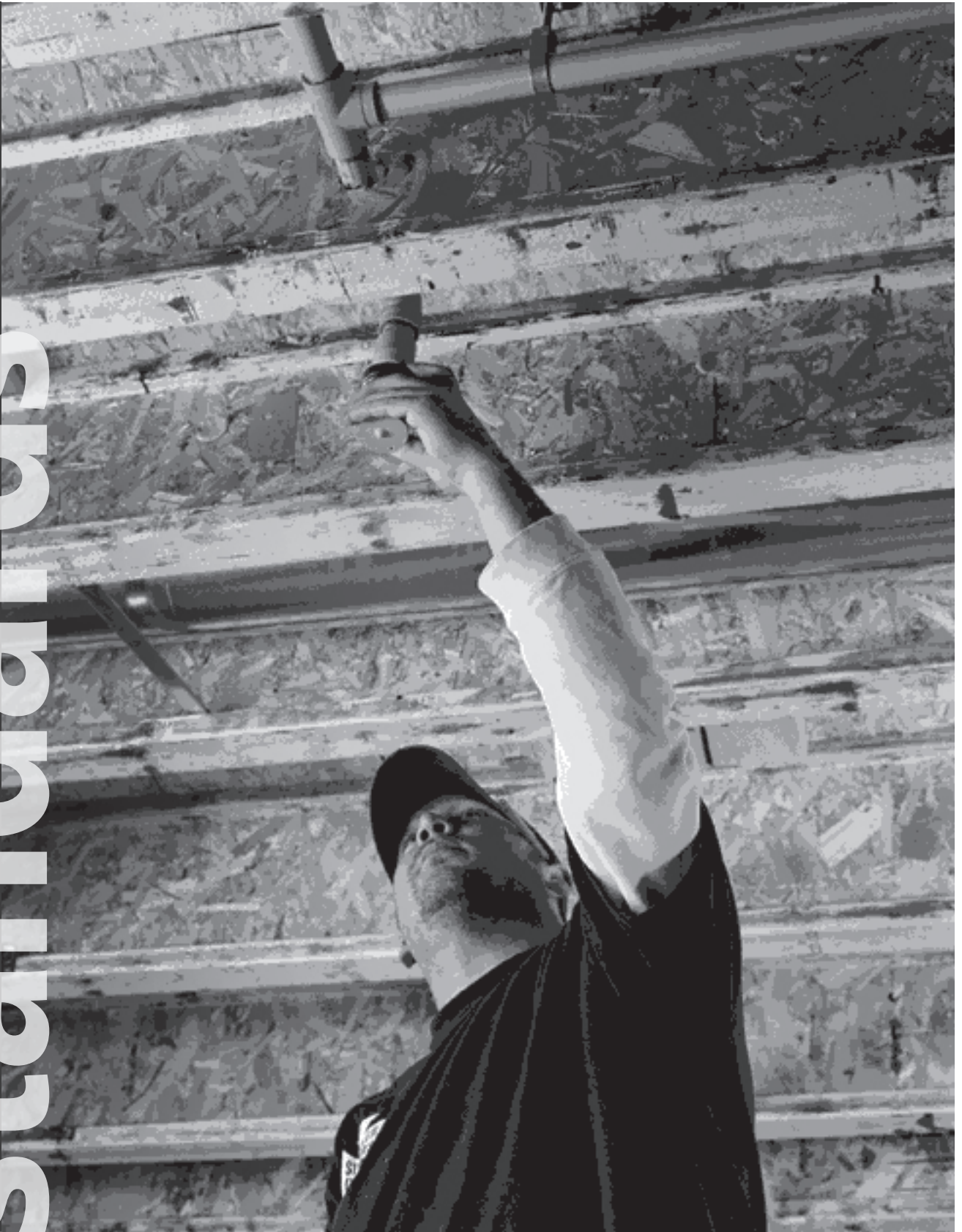

## Fire Protection Systems

200 S. Ivy St. - Room 177, Medford, Oregon 97501  
541-774-2430 • [wtrcom@ci.medford.or.us](mailto:wtrcom@ci.medford.or.us) • [medfordwater.org](http://medfordwater.org)



# **Standards For Fire Protection Systems**

## **Board of Water Commissioners**

Jason Anderson, Chair  
Cathie Davis, Vice Chair  
Leigh Johnson  
John Dailey  
Lee Fortier

## **Management**

Larry Rains, P.E., Manager  
Eric Johnson, P.E., Principal Engineer  
Ken Johnson, Operations Superintendent

Approved by Resolution No. 1501  
At the Regular Meeting of the Board of Water Commissioners  
October 17, 2012

## **Medford Water Commission**

200 S. Ivy St. – Room 177  
Medford, OR 97501  
Phone: (541) 774-2430 / Fax: (541) 774-2555  
Email: [wtrcom@ci.medford.or.us](mailto:wtrcom@ci.medford.or.us) / Web: <http://www.medfordwater.org>

**RESOLUTION NO. 1501**

A RESOLUTION Adopting the Medford Water Commission's Standards for Water Facilities, Fire Protection Services, and Backflow Prevention Assemblies, as revised October 17, 2012

WHEREAS, the Commission's Standards are generally reviewed by staff every two years; and

WHEREAS, the last revisions to the Standards were approved in 2009; and

WHEREAS, staff has reviewed and evaluated all materials supplied to ensure they meet the standards of the Commission; and

WHEREAS, staff provided a study session on the Standards to the Board prior to their regular meeting on October 3, 2012; and

WHEREAS, electronic versions of the three publications were available for review by the Board of Water Commissioners (Board) and the public on the Commission's website prior to the October 3, 2012 board meeting; and

NOW, THEREFORE, BE IT RESOLVED BY THE BOARD OF WATER COMMISSIONERS OF THE CITY OF MEDFORD, OREGON, AS FOLLOWS:

That the Standards for Water Facilities, Fire Protection Services, and Backflow Prevention Assemblies, as revised October 17, 2012, and as set forth in Exhibits A, B and C, copies of which are on file in the Commission's office and by reference made a part hereof, are hereby approved and become effective immediately.

PASSED at a regular meeting of the Board of Water Commissioners and signed by me in authentication thereof this 17th day of October 2012.

ATTEST:   
Karen Spoonts, Deputy City Recorder

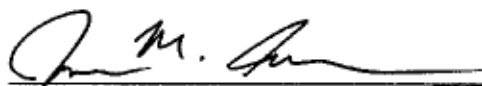
  
Jason Anderson, Chair

# TABLE OF CONTENTS

## SECTION I REGULATIONS

- I-A Authority
- I-B. General Statement
- I-C. Water System
- I-D. Size and Arrangement
- I-E. Charges for Service and Installation
- I-F. Violation of Regulations
- I-G. Pressure and Supply
- I-H. Backflow Protection
  1. Approved Reduced Pressure Principle Backflow Prevention Assembly (RP)
  2. Approved Reduced Pressure Principle-Detector Backflow Prevention Assembly (RPDA)
  3. Approved Double Check Valve Backflow Prevention Assembly (DC)
  4. Approved Double Check-Detector Backflow Prevention Assembly (DCDA)
  5. No Backflow Protection Required
  6. Residential Fire Sprinkler Systems (NFPA 13D)
- I-J. Testing
- I-K. Location
- I-L. Underground Piping
- I-M. Installation Requirements
- I-N. Responsibility for Fire Service
- I-O. Fire Service Abandonment

## SECTION II GENERAL REQUIREMENTS

- II-A. General
- II-B. Plan Submittal
- II-C. Plan Details
- II-D. General Notes

## SECTION III GENERAL SPECIFICATIONS

- III-A. Scope of Work
- III-B. Control of Work
- III-C. Inspection
- III-D. Approval of Contractor and Pipeline Installer
- III-E. Construction
- III-F. Materials
- III-G. Permits
- III-H. Backflow Prevention Assemblies

- III-I. Bypass Meter
- III-J. Vaults
- III-K. Safety
- III-L. Completion

**SECTION IV INSTALLATION STANDARDS**

- IV-A. Reduced Pressure Principle Backflow Prevention Assembly (RP)
- IV-B. Double Check Valve Backflow Prevention Assembly (DC)
- IV-C. Double Check-Detector Backflow Prevention Assembly (DCDA)
- IV-D. Reduced Pressure Principle- Detector Backflow Prevention Assembly (RPDA)

**SECTION V APPROVED BACKFLOW PREVENTION ASSEMBLIES**

**SECTION VI STANDARD SPECIFICATIONS**

**SECTION VII STANDARD DETAIL DRAWINGS (October 2009)**

**SECTION I**  
**REGULATIONS**

## **I-A. AUTHORITY**

1. OAR Chapter 333 Division 061 Rules for Public Water Systems require water suppliers to conduct an active program for systematically identifying and controlling cross connections. The standards set forth for Fire Protection Systems are minimum requirements for safe practice in the delivery of water. They are to be interpreted as meeting only the minimum requirements of design, construction, maintenance, and operation of the water utility system.
2. As set forth in Medford Water Commission's (MWC's) *Regulations Governing Water Service and Standards for Fire Protection Systems*, compliance with cross connection control rules is mandatory.
  - a) MWC may immediately discontinue service to any premises where actual or potential cross connections exist.
3. As a condition of water service, customers shall install, maintain, and operate their piping and plumbing systems in accordance with the State of Oregon Plumbing Specialty Code and the Oregon Administrative Rules Chapter 333, Division 061, Public Water Systems addressing cross connection control and backflow prevention assemblies and, if applicable, in accordance with the City of Medford Plumbing Code.
  - a) Plumbing permits are required by the City of Medford or Jackson County when installing backflow prevention assemblies. Please contact these agencies for information about plumbing permits.

## **I-B. GENERAL STATEMENT**

For the purpose of these minimum requirements, the word "shall" indicates a mandatory requirement and the word "should" indicates a recommendation for good waterworks practice.

## **I-C. WATER SYSTEM**

1. The water system shall be considered as made up of two parts: the utility system and the customer system.
2. The utility system shall consist of the source of facilities and the distribution system, and shall include all those facilities of the water system under the complete control of the utility, up to the point where the customer system begins, generally at the water meter, which is at the easement line or property line.
3. The customer system shall include those parts of the facilities which convey domestic water to points of use beyond the termination of the utility system. The term "customer system" is that of any user whether or not a charge is made.

## **I-D. SIZE AND ARRANGEMENT**

Subject to approval of plans for each installation, MWC will approve standby fire protection service connections of the size and location requested by the applicant

but not less than two (2) inches or more than twelve (12) inches in size. Such service connections will be approved only if adequate provisions are made to prevent the use of water from such services for purposes other than fire extinguishing and if a main exists of adequate size to supply the requested service. Approved backflow prevention assemblies must be installed to prevent the re-entry of water into the public water system from back-siphonage or back-pressure and shall be installed on all standby fire protection service connections for any fire sprinkler system and to those to which hose lines, hydrants, or any other water outlets for fire extinguishing are connected.

#### **I-E. CHARGES FOR SERVICE AND INSTALLATION**

Charges for standby fire protection service shall be in accordance with MWC's regularly scheduled charges and rates. No charge will be made for water used to extinguish accidental fires or routine testing of a fire protection system. The customer shall pay the full cost of the installation of the standby fire protection service connections, any required meters or backflow prevention assemblies and any special water mains installed solely for service to the standby connections. Maintenance of any required facility shall be the sole responsibility of the customer. MWC shall only maintain the bypass meter and the water main from the connection to the existing water main to the front of the fire service vault.

#### **I-F. VIOLATION OF REGULATIONS**

If water is used from a fire service in violation of these regulations, an estimate of the amount used will be computed by MWC, and the customer shall pay for the water used at the regular metered rates, including the monthly service charge. MWC may also require that future service for such connection be through a meter at regularly scheduled metered rates, after notice, or MWC may discontinue the service.

#### **I-G. PRESSURE AND SUPPLY**

MWC assumes no responsibility for loss or damage because of lack of water or pressure and merely agrees to furnish such quantities and pressures as are available in its general distribution system. The service is subject to shut-downs and variations required by the operation of the system.

#### **I-H. BACKFLOW PROTECTION**

The type of backflow protection installed between the municipal system and the private fire system shall depend upon the private system configuration and the degree of hazard as follows:

1. Approved Reduced Pressure Principle Backflow Prevention Assembly (RP):
  - a) Any system with antifreeze, corrosion inhibitor, or other chemicals added to a fire protection system supplied from the potable water supply, and is not isolated with approved backflow protection at the service connection.



- b) Any system where an auxiliary water source may be connected to the private fire system.
2. Approved Reduced Pressure Principle-Detector Backflow Prevention Assembly (RPDA):
- This device may be utilized for a reduced pressure principle assembly in all installations where detector metering is required.
3. Approved Double Check Valve Backflow Prevention Assembly (DC):
- a) Any system with pumper connection.
  - b) Any system with private fire hydrants.
  - c) Any looped system (immediately downstream of each meter to prevent circulating flow).
  - d) Any system containing non-potable water piping.
  - e) Any "Stand-Alone" residential fire sprinkler systems as defined below.
4. Approved Double Check-Detector Backflow Prevention Assembly (DCDA):
- This device may be utilized for an approved double check valve assembly in all installations where detector metering is required.
5. No Backflow Protection Required:
- a) Any residential "multipurpose" or "Combination" fire sprinkler system as defined below.
6. Residential Fire Sprinkler Systems (NFPA 13D):
- a) "Stand-Alone" Fire Sprinkler Systems have a separate water supply that is tapped off the domestic water service to the house. Such a system contains standing water and may be installed using non-potable piping. A Double Check Valve Backflow Prevention Assembly is required at the branch to the fire system.
  - b) "Multipurpose" or "Combination" Fire Sprinkler Systems share common piping with the domestic water supply inside the home. These systems are part of the customer's potable water line, are constructed of materials approved for potable water systems, and end at a routinely used plumbing fixture (allowing for periodic flow during each 24-hour period). There are no dead end lines containing standing water.

## **I-J. TESTING**

All Assemblies must be tested upon installation and at least once per year thereafter by an approved certified tester. Records of such tests and repairs will be maintained by MWC, and it is the responsibility of any backflow prevention assembly tester performing

tests and maintenance on backflow prevention assemblies to submit records of such tests and repairs to MWC.

It shall be the responsibility of the owner of the property served to keep backflow prevention assemblies in good working condition at all times. It shall also be the responsibility of the owner of the property at any premise where backflow prevention assemblies are installed to have thorough inspections and assembly performance/leakage tests made at least once a year. In those instances, as determined by MWC, where successive inspections indicate failure or where there are facilities that pose extreme health risks, more frequent testing will be required. These inspections and tests shall, at the expense of the owner of the property, be performed by a State certified person approved by MWC as a competent backflow assembly tester. It is the responsibility of MWC's representative to see that these tests are made. At the discretion of MWC, approved backflow assembly testers may be required to notify MWC in advance when the test is to be undertaken so that a MWC representative may witness the test. Backflow prevention assemblies shall be repaired, overhauled or replaced promptly at the expense of the owner of the property whenever they are found to be defective. Non-compliance may cause water service to be denied or discontinued. Records of such tests and repairs will be maintained by MWC, and it is the responsibility of any backflow prevention assembly tester performing tests and maintenance on backflow prevention assemblies to submit records of such tests and repairs, to MWC.

#### **I-K. LOCATION**

Backflow prevention assemblies shall be in an outside enclosure at the property line or on the private side of a Public Utility Easement (P.U.E). Backflow prevention assemblies shall not be located in the P.U.E. unless written authorization is obtain from all utility companies governing the use of the P.U.E. Backflow prevention assemblies shall not be located in the Public Right of Way unless written authorization is obtain from City of Medford Public Works Department. No fences or gates will be allowed to obstruct access to the device. All assemblies shall be set a maximum of 36 inches from the top of vault to the top of mainline pipe.

All backflow prevention assemblies for fire systems shall be located as stated previously unless special permission to locate such assemblies elsewhere in existing building situations is granted by MWC.<sup>1</sup>

The backflow prevention assemblies, when and if allowed inside existing buildings, must meet all of the following conditions:

1. Special permission must be granted by MWC and any special requirements followed.
2. The maximum length of service line from the backflow prevention assembly to the property line and/or MWC easement line shall not exceed fifteen feet (15').

#### **I-L. UNDERGROUND PIPING**

---

<sup>1</sup> It is the policy of MWC not to allow fire service backflow prevention assemblies inside buildings.

All water mains serving the fire service that are maintained by MWC shall be ductile iron pipe in accordance with MWC's *Standard Specifications for Ductile Iron Pipe and Cast Iron Fittings*.

#### **I-M. INSTALLATION REQUIREMENTS**

All backflow protection installed shall comply with the installation guidelines included in Section IV of "Standards for Fire Protection Systems" and defined as follows:

- IV-A. Reduced Pressure Principle Backflow Prevention Assembly (RP)
- IV-B. Double Check Valve Backflow Prevention Assembly (DC)
- IV-C. Double Check-Detector Backflow Prevention Assembly (DCDA)
- IV-D. Reduced Pressure Principle-Detector Backflow Prevention Assembly (RPDA)

#### **I-N. RESPONSIBILITY FOR FIRE SERVICE**

For those places where the assembly is placed within the building, the owner shall be responsible for the maintenance and repair of the fire service, and damage caused by the fire service in all areas outside public right-of-way or MWC easement.

#### **I-O. FIRE SERVICE ABANDONMENT**

Any active service account electing to permanently disconnect an existing standby fire service will be required to pay all costs involved with the full abandonment of the fire service at the main. Written approval/acknowledgement from the jurisdictional fire department and the insurance company insuring the property must be submitted to MWC prior to abandonment of the fire service.

## **SECTION II**

# **GENERAL REQUIREMENTS**

## II-A. GENERAL

1. These guidelines are for the purpose of establishing standard procedures for developing designs for fire protection systems to conform with MWC's *Regulations Governing Water Service*. No approval of variances from these guidelines or estimates of costs will be given prior to submittal of plans for review.
2. Whenever the following terms are used in these requirements, specifications and special provisions, they are to be interpreted as being synonymous with the accompanying full title:

<u>TERMS</u>	<u>FULL TITLE</u>
MWC	Medford Water Commission
City	City of Medford
Contractor	Firm or corporation contracting with the developer to perform the work; Contractor and the person installing the pipe must be prequalified.
Council	City Council of Medford, Oregon
County	County of Jackson
Developer	Individual, partnership, firm or corporation proposing construction of water facilities which are a planned extension to the existing Medford Water Commission system
Engineer	Consulting engineer for the developer
Engineering Division	Engineering Division of MWC
Inspector	Inspector for the MWC
Manager	Manager of the MWC
Responsible Party	Individual, partnership, firm or corporation proposing construction of water facilities which are a planned extension to the existing MWC system
State	State of Oregon
Surveyor	Surveyor for the developer

### 1.00.01 RESPONSIBLE PARTY

The "Responsible Party" form (Appendix H, *Standards for Water Facilities*) shall be filled out completely and on file with MWC prior to any work starting on the project.

## II-B. PLAN SUBMITTAL

1. The developer shall submit one (1) set of prints of the proposed installation for first plan check. The Engineering Division will check the drawings and return the drawings (redlines) to the Engineer for corrections. The Engineer will address the corrections and resubmit the corrected drawings and the first plan check

comments to MWC for further plan check if required. All previous redlines must be submitted to MWC at time of resubmittal for plan check.

2. Upon completion of plan check, the Engineering Division will issue a fee letter with an estimate of charges for plan check, work to be performed by MWC (such as tapping, inspection, flushing, testing, disinfection, sampling, and record drawings, etc.), and notify the developer via their Engineer of the amount to be deposited. The plans must be approved and signed by the City of Medford, Public Works Department, and City Engineer prior to MWC approving the plans (if applicable). If the project lies in the County and/or ODOT right of way, then the plans must be approved by those agencies (if applicable) prior to MWC approval.
3. The Developer and Engineer will incorporate any necessary corrections and furnish MWC with an electronic disk of the final drawings using a CD, AUTOCAD Release 2008 format, and two (2) full printed sets of final drawings and four (4) additional sets of prints of the water improvement plans only. Final printed plans shall be at full scale on 24" by 36" paper.
4. Signed and notarized easement shall be provided for recordation.
5. The fee deposit as outlines in the development agreement shall be paid in full to MWC.
6. The owner will be requested at this point to sign a development agreement, acknowledging those responsibilities required of them for finalization and acceptance of the water facilities.
7. Upon receipt of the plans, easements, fees and development agreement, the Engineering Division will initiate a work order, and return two (2) sets of drawings marked "Approved" to the contractor at a pre-construction meeting.
8. Approval of plans by MWC shall expire one year from the approval date. Approved plans become void if the design changes. Changes to the approved designed requires resubmittal of the plans for review and approval. Plans that have been approved (fees not paid and work order not issued) by MWC, but have not been constructed within one year of approval will be returned to the Engineer of record. Resubmittals of updated plans are required for the project to move forward.

## **II-C. PLAN DETAILS**

The following standards are outlined for general use in preparing plan and profile drawings of water facilities for MWC.

1. All plans are to be prepared and signed by a registered engineer in the State of Oregon.
2. All plans are to be drawn on 24" by 36" sheet. All plans shall be drawn to scale. The scales for the plan view shall be engineering scales of: 1" to 50', 1" to 40', 1" to 30', 1" to 20' and 1" to 10'. The scales for the profile view shall be engineering scales of: 1" to 5', 1" to 4', 1" to 3', 1" to 2" and 1" to 1'. Details on the plans may

use smaller scales if required. Architectural scales are not allowed for engineering drawings.

3. Vicinity Map of the project area shall be provided showing proposed installations in relation to nearest cross streets.
4. Project name, north arrow and bar scales shall be shown on the plans.
5. Plan View: Sizes and materials of existing and proposed water mains, valves, fitting, service lines, meter, fire hydrants and all other water appurtenances shall be shown in plan views. Stationing and offsets of all water facilities shall be shown on the plans. Easements shall be shown and dimensioned on the plans. Lot numbers and street names shall be shown on the plans. All existing and proposed utilities shall be shown and dimensioned on the plans. Street improvements including driveway approaches shall be shown on the plans.

Street centerline stations shall be used as reference stationing for water mains, fire hydrants, valves, fittings, and water service connections. Where water mains cannot be referenced to or deviate from street centerline stationing, dimensions for length shall be indicated on the plan view.

The backflow prevention device and enclosure shall be provided indicating dimensions, piping connections ties to existing water facilities, thrust anchorage, vault type and size, backflow prevention assembly type and size, other utility locations, and elevation.

Pressure zones and pad elevations shall be shown on plans when there are multiply pressure zones in a project.

MWC general notes shall be shown on all plans.

Construction notes shall be shown on all plans. Construction notes shall address both existing and proposed water facilities and any item effecting water facilities.

Any item that would add to the clarity and constructability to the plan should be shown.

6. Profile View: Profiles of pipeline invert and soffit are to be plotted directly below the plan views. The existing and/or proposed street profile shall be used for final grade to base the water main profile on.

Sizes of water mains, types of classes of pipes, air release valves, length or restraint pipe, casings and backfill classifications are to be shown in the profile view.

Stationing and grades of pipes are to be shown in the profile view.

All utility crossings (i.e., sanitary sewer, storm drain, irrigation pipes, existing water mains, electrical, natural gas, telephone, fiber optic, and etc.) are to be shown and labeled in the profile view.

Any item that would add to the clarity and constructability to the plan should be shown in the profile view.

## II-D. GENERAL NOTES

1. The following general note shall appear on the plans:

*"All water works shall be constructed in accordance with the current version of Medford Water Commission's Standards and Regulations."*

2. The following notes should appear once on the plans, but in any case apply to all sheets:
  - a) Service connections are to be installed for each parcel per MWC standards (Standard Details Nos. 100 and 101).
  - b) Cover over existing mains shall not be changed without written authorization of MWC.
  - c) New mains are to be pressure tested, disinfected and proven to be bacteriologically safe prior to placing new mains in service by MWC. Pressure testing shall not be done until all excavation and backfill up to subgrade has been established.
  - d) Initial backfill to top of water mains and fire hydrants runs shall be compacted in accordance with MWC's "Standard Specification for Trench Excavation and Backfill," or backfill material and compaction shall meet the requirements of the controlling agency.
  - e) Water mains and fire hydrants are to be installed with reference alignment and grade status and only upon notification of the MWC Inspector.
  - f) Water mains are to be installed after sewers.
  - g) Fire hydrant runs are to be installed before curbs and gutters. In the event a water main is installed larger than eight (8) inches, or if the main has more than three (3) feet of cover, the contractor will be required to install an offset similar to "Standard Drawing 105" to permit use of a standard 3'-6" bury fire hydrant.
  - h) Stubs service runs shall be installed prior to curb and gutter and after PUEs are graded to curb levels.
  - i) Approved plans and specification shall be available at site of construction at all times during construction of water facilities.
  - j) Copies of the MWC's "Standard Specifications" should be obtained at the office of MWC.
  - k) Separation of water main, including service lines and sanitary sewer, shall be in accordance with current Oregon State Health Division Rules and/or as



modified in Section IV, Item II, C-8 of these Standards except in all cases running parallel with each other, there shall be a 10-foot separation center line to center line.

- l) No above-ground appurtenances or physical structures of any kind shall be within five (5) feet of any water facility whether that water facility is above or below ground. This distance shall be ten (10) feet when water and sanitary sewer facilities are concerned.
- m) No below-ground utility lines or other service of any kind shall be within five (5) feet of any water facility when running parallel to the water facility.
- n) No below-ground utility lines or other service of any kind shall be within six (6) inches of any water facility when running parallel or approximately perpendicular to the water facility. This distance shall be eighteen (18) inches when water and sanitary sewer facilities are concerned.
- o) Blasting or explosive work will not be allowed within 30 feet of existing water facilities and only then using proper industry standards and through a permit process with the Fire Department or other agency jurisdiction.
- p) MWC requires "poly pigs" to be used on all newly laid water lines.
- q) All dry tap water services and air release valves shall be installed by a MWC-pre-qualified installer.

## **SECTION III**

# **GENERAL SPECIFICATIONS**

### **III-A. SCOPE OF WORK**

1. It is the developer's responsibility to have all work done in accordance with approved plans and MWC's "Standard Specifications."
2. Any change or alteration in approved plans will require written consent of the Engineering Division.
3. MWC will assist in marking and locating MWC facilities through the Oregon Utility Notification Center system.

### **III-B. CONTROL OF WORK**

1. The Engineering Division will decide all questions which may arise as to the quality of acceptability of materials furnished and work performed. The Engineering Division will have the authority to decide on the acceptable fulfillment of all phases of work.
2. Finished construction shall conform with grades and dimensions shown on approved plans. Deviations from approved plans, as may be required by the necessities of construction, will be determined in all cases by the Engineering Division and significant deviations must first be authorized in writing.
3. Construction not included as part of the original plans must first be given written approval by the Engineering Division.
4. Failure to comply with the aforementioned requirements will be cause for rejection of the work.

### **III-C. INSPECTION**

1. MWC's Inspector shall at all reasonable times have access to the work during construction and shall be furnished every reasonable facility for ascertaining full knowledge regarding adherence to approved plans, workmanship and type, and quality of materials used in the work.
2. Work which is defective in its construction or deficient in any of the specified requirements shall be removed and replaced to the satisfaction of MWC.
3. Failure to comply with any part of the approved plans may be sufficient cause to reject the work. Deviations will be called to the attention of the developer or contractor at the time it is noted. Failure to comply by making the necessary corrections will result in sending of a written notification to both the contractor and the developer and the work thereafter will not be accepted until after corrections have been made to the satisfaction of MWC.

4. The fire service will be turned on only by MWC's Inspector for testing of backflow prevention assemblies and after final inspection.

### **III-D. APPROVAL OF CONTRACTOR, PIPE INSTALLER**

The contractor and person installing the pipe and water facilities shall be approved by MWC. Calendar year prequalification information shall be submitted on MWC's "Contractor Prequalification Application" forms.

The Contractor must list previous work related to "Ductile Iron Pipe Installation" or other items related to particular projects, with references and telephone numbers.

The Contractor may be required to attend a meeting with MWC field personnel with their service truck and explain their planned approach to the project as well as knowledge of our printed standards. Determination of prequalification may be based solely on this information.

It must be understood that MWC inspects waterline work for acceptance into the public system but does not teach the techniques for proper installation. Having the knowledge of techniques for proper installation is the responsibility of the contractor to already possess. New persons wanting to learn the process should work under an experience Contractor and then apply for prequalification keeping in mind their first few jobs will necessitate increased inspection time until a sense of confidence is achieved by MWC.

Work performed by other than approved contractors and people installing the pipe will not be accepted.

### **III-E. CONSTRUCTION**

1. All material and workmanship utilized in the construction of facilities that MWC assumes ownership of shall be in accordance with the attached "Standard Specifications for Trench Excavation, Backfill and Shoring" and "Ductile Iron Pipe, Cast Iron Fittings, Valves, and Fire Hydrants."
2. Facilities shall be installed in strict accordance with plans.
3. MWC shall be notified 48 hours in advance of construction.
4. All materials and workmanship utilities in the construction of facilities that MWC assumes ownership of shall be guaranteed for a period of one year following date of acceptance by MWC.
5. Approved plans shall be available at the site of construction at all times during construction.

6. Prior to backfill operations, water facilities installation shall be inspected by the MWC Inspector to ensure compliance with the plans and specification. Contractors shall notify MWC 48 hours in advance for inspections.
7. It shall be the contractor's responsibility to arrange for inspection prior to backfilling operations.
8. Contractor shall provide excavation, backfill, shoring, surfacing, trench plates, traffic control and etc. when assisting MWC forces.
9. Work activities on water projects shall be confined to normal MWC working hours (8 a.m. to 5 p.m. – Monday to Friday).

### **III-F. MATERIALS**

1. All materials shall be new and meet the specified requirements. No other materials will be accepted. All materials shall be new and meet the specified requirements. All materials shall be as listed in the "Standard Specifications" or as approved by MWC.
2. MWC will refuse to accept for use any materials which are defective or damaged. Installation of any such materials will result in rejection and subsequent request for removal and replacement before acceptance.

### **III-G. PERMITS**

It is the obligation of the developer or contractor to obtain whatever permits may be legally required prior to the start of construction.

### **III-H. BACKFLOW PREVENTION ASSEMBLIES**

Approved backflow prevention assemblies shall be furnished by the applicant where required and installed in accordance with the appropriate schedules contained herein.

The types of assemblies approved by MWC are identified in the current "Approved Backflow Prevention Assembly Listing" provided by the Oregon Health Authority. In case of discrepancies, the most recent Health Division listing or addenda will prevail (see **Section V: APPROVED BACKFLOW ASSEMBLIES PREVENTION ASSEMBLIES** for more information).

All assemblies must be tested upon installation and at least once per year thereafter by an approved certified tester. Records of such tests and repairs will be maintained by MWC, and it is the responsibility of any backflow prevention assembly tester performing tests and maintenance on backflow prevention assemblies to submit records of such tests and repairs to MWC.

### **III-I. BYPASS METER**

The touch/read bypass meter shall be 5/8" x 3/4" in size, and shall be used on double check detector assemblies or reduced pressure principal detector assemblies and must be purchased from MWC. MWC shall also set the bypass meter at current charges for special services.

### **III-J. VAULTS**

Vaults and lids shall be approved\*<sup>1</sup> pre-cast type. All vaults shall be well drained, constructed of suitable materials, and sized to allow for the minimum clearances established.

MWC provides only initial inspection and approval of vaults and appurtenances. Vaults, lids, and the backflow assemblies are owned by the property owner, and they incur all responsibility and liability of these items. These items shall be maintained by the property owner. Vault owners must recognize that many vaults can be considered a "confined space" where oxygen deficiency or toxic atmosphere may exist. The Oregon Occupational Safety and Health Administration (OSHA) mandate specific requirements for confined space entry.

No fire department pumper connections shall be installed through vault lids.

Vaults shall be provided with a sump pump when in potential groundwater installations. Brass or plastic plugs are required in all assembly test ports when assemblies are installed in a vault below grade.

### **III-K. SAFETY**

Safety is the sole responsibility of the contractor. It is the contractor's responsibility to conform to all OSHA or other safety regulations. MWC inspector is not responsible for patrolling safety issues.

### **III-L. COMPLETION**

1. Upon completion of the project, the contractor will notify MWC 48 hours in advance of a desired final inspection.
2. MWC will in turn furnish a "Dedication and Declaration of Acceptance of Water System Facilities" form to be executed by the owner and MWC. The owner's Dedication provides for a one (1) year guarantee from the date of acceptance in which the owner agrees to indemnify and hold harmless MWC from any and all defects appearing or developing in the workmanship or material performed or furnished in the construction of the described water system facility.

---

<sup>1</sup> \* See Section VII – Standard Detail Drawings – No. 800

3. The owner/contractor is required to supply a statement of actual cost of the project on the "Dedication and Declaration" form.

**SECTION IV**

**INSTALLATION  
STANDARDS**



## INSTALLATION STANDARDS

Only assemblies approved for vertical installation by Oregon Department of Human Services and MWC, including the proper direction of flow, may be installed vertically.

*(Refer to Section VI, "Standard Detail Drawings" for backflow assembly installations)*

### IV-A. REDUCED PRESSURE PRINCIPLE BACKFLOW PREVENTION ASSEMBLY (RP)

RPs may be utilized at premises where the substance which could backflow is hazardous to health. The RP is normally used in locations where an air gap is impractical and is effective against both backsiphonage and backpressure.

1. RPs must be sized to provide an adequate supply of water and pressure for the premises being served. Flow characteristics are not standard. Consult manufacturer's specifications for specific performance data.
2. Premises where interruption of the water supply is critical should be provided with two assemblies installed in parallel. They should be sized in such a manner that either assembly will provide the minimum water requirements while the two together will provide the maximum flow required.
3. Bypass lines are not permitted. Pipe fittings which could be used for connecting a by-pass line must not be installed.
4. The assembly must be readily accessible for testing and maintenance and must be located in an area where water damage to building or furnishings would not occur from relief valve discharge. An approved air gap funnel assembly may be used to direct minor discharges away from the assembly; the air gap funnel will not control flow in a continuous relief situation. Drain lines to accommodate full relief valve discharge flow should be considered. Relief valves shall not be extended or plugged.

RPs are typically installed above grade in well drained areas, but may be installed below grade if an adequate drain to daylight is provided.

Enclosures shall be designed for easy access and sized to allow for the minimum clearances established below. Removable protective enclosures are typically installed on smaller assemblies. Daylight drain port must be provided to accommodate full pressure discharge from the assembly.

All assemblies shall have a minimum of 12 inches on the back side, 24 inches on the test cock side, and the relief valve opening shall be at least 12 inches plus nominal size of assembly above the floor or highest possible water level.

Minimum clearances for assemblies 2 inches or smaller may be reduced provided that they are accessible for testing and repairing and approved by the water purveyor. The 12-inch minimum clearance below the relief valve must be maintained.

Maximum height of installation shall not exceed 5 feet for assemblies unless there is a permanently installed platform meeting Occupational Safety and Health (OSHA) standards to facilitate servicing the assembly.

5. The assembly must be protected from freezing and other severe weather conditions.
6. Vertical installation is not permitted.
7. Lines should be thoroughly flushed prior to installation. A strainer with blow out tapping is recommended ahead of the assembly.
8. The property owner assumes all responsibility for leaks and damage.
9. All RPs must be tested upon installation and at least once per year thereafter by an approved certified tester. Records of such tests and repairs will be maintained by MWC, and it is the responsibility of any backflow prevention assembly tester performing tests and maintenance on backflow prevention assemblies to submit records of such tests and repairs to MWC.
10. RPs shall be installed above the 100-year flood level.
11. Variances from these specifications will be evaluated on a case by case basis. Any deviations must have prior written approval of the MWC.

#### **IV-B. DOUBLE CHECK VALVE BACKFLOW PREVENTION ASSEMBLY (DC)**

DCs may be installed at premises where the substance which could backflow is objectionable but not hazardous to health.

1. DCs must be sized to provide an adequate supply of water and pressure for the premises being served. Flow characteristics are not standard. Consult manufacturer's specifications for specific performance data.
2. Premises where interruption of water supply is critical should be provided with two assemblies installed in parallel. They should be sized in such a manner that either assembly will provide the minimum water requirements while the two together will provide the maximum flow required.
3. Bypass lines are not permitted. Pipe fittings which could be used for connecting a bypass line shall not be installed.
4. The assembly shall be readily accessible with adequate room for testing and maintenance. DCs may be installed below grade in a vault, provided water-tight brass or plastic plugs are installed in the test cocks. The assembly shall not, however, be subject to continuous immersion. All vaults shall be well drained, meet MWC vault standards, and be sized to allow for the established minimum clearances.

Assemblies 2 inches and smaller shall have at least 12-inch clearance below and 3-inch clearance on both sides of the assembly. All assemblies larger than two

(2) inches shall have a minimum clearance of 12 inches on the back side, 24 inches on the test cock side, and 12 inches below the assembly.

Maximum height of installation shall not exceed 5 feet for assemblies unless there is a permanently installed platform meeting Occupational Safety and Health (OSHA) standards to facilitate servicing the assembly.

5. DCs may be installed vertically as well as horizontally provided that the assembly is approved for vertical installation by Oregon Department of Human Services and MWC, including the proper direction of flow.
6. The assembly must be protected from freezing and other severe weather condition.
7. Lines should be thoroughly flushed prior to installation. A strainer with blow out tapping is recommended ahead of the assembly.
8. The property owner assumes all responsibility for foundation or basement wall penetration, leaks, and damage. The owner shall also see that the vault is kept reasonable free of silt and debris.
9. All DCs must be tested upon installation and at least once per year thereafter by an approved certified tester. Records of such tests and repairs will be maintained by MWC, and it is the responsibility of any backflow prevention assembly tester performing tests and maintenance on backflow prevention assemblies to submit records of such tests and repairs to MWC.
10. Variances from these specification will be evaluated on a case by case basis. Any deviations must have prior written approval of MWC.

#### **IV-C. DOUBLE CHECK-DETECTOR BACKFLOW PREVENTION ASSEMBLY (DCDA)**

DCDAs may be utilized in all installations requiring a double check valve assembly and detector metering.

1. DCDAs shall comply with the installation requirements applicable for double check valve assemblies.
2. Bypass meters for DCDAs must be purchased from MWC.

#### **IV-D. REDUCED PRESSURE PRINCIPLE-DETECTOR BACKFLOW PREVENTION ASSEMBLY (RPDA)**

RPDAs may be utilized in all installations requiring a reduced pressure backflow assembly and detector metering.

1. RPDAs shall comply with the installation requirements applicable for reduced pressure backflow assemblies.
2. Bypass meter for RPDAs must be purchased from MWC.

## **SECTION V**

# **APPROVED BACKFLOW PREVENTION ASSEMBLIES**

## V. APPROVED BACKFLOW PREVENTION ASSEMBLIES

Under current Oregon Administrative Rule 333-061-0070 Oregon Health Authority-approved *testable* backflow prevention assemblies shall be assemblies approved by the University of Southern California (USC), Foundation for Cross Connection Control and Hydraulic Research. Membership to the Foundation is required for access to this list of approved assemblies. The Oregon Health Authority has limited permission from USC to provide this reformatted list to public water systems and water system consultants working within Oregon. New assemblies approved by USC are available on cumulative addendums prepared throughout the year.

### For information on approved backflow prevention assemblies contact:

Oregon Health Authority Drinking Water Program  
Cross Connection/Backflow Prevention Program (DWP CC/BPP)  
PO Box 14450  
Portland, OR 97293-0450

Phone: (971) 673-1220  
Phone: (971) 673-0405  
Fax: (971) 673-0694  
TTY: (971) 673-0372

Web site:

<http://public.health.oregon.gov/HealthyEnvironments/DrinkingWater/CrossConnection/Pages/index.aspx>

### OR

Medford Water Commission  
200 S. Ivy St. – Room 177  
Medford, OR 97501

Phone: (541) 774-2450 or (541) 774-2447

Web site: [www.medfordwater.org](http://www.medfordwater.org)

**SECTION VI**

**STANDARD  
SPECIFICATIONS**

## VI. STANDARD SPECIFICATIONS

**Refer to MWC's *Standards for Water Facilities (Green Book)*, latest edition.**

- I Standard Specifications for Trench Excavation, Backfill and Shoring
- II Standard Specifications for Ductile Iron Pipe, Ductile Iron Fittings, Valves, and Fire Hydrants

# **SECTION VII**

## **STANDARD DETAIL DRAWINGS**



**STANDARD DETAIL DRAWINGS  
FOR  
BACKFLOW PREVENTION FOR  
FIRE PROTECTION SYSTEMS**

**TABLE OF CONTENTS**

<b><u>Standard Detail No.</u></b>	<b><u>Description</u></b>
<b>800</b>	Pre-cast Non-Traffic Vault and Lid
<b>802</b>	Reduced Pressure Principle Assembly (RP)
<b>803</b>	Reduced Pressure Principle Detector Assembly (RPDA)
<b>805</b>	Double Check Valve Assembly (DC)
<b>807</b>	Double Check Detector Assembly (DCDA)

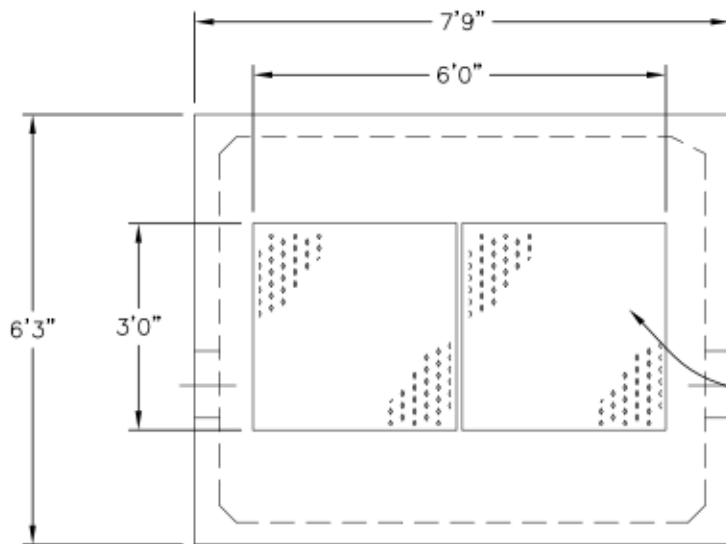

**NOTE:**

1. THIS IS A GENERAL DRAWING FOR MINIMUM REQUIREMENTS.
2. FIRE DEPARTMENT CONNECTION AND CHECK VALVE MAY BE IN VAULT, BUT NOT THROUGH LID OR TOP.

HOT-DIPPED GALVANIZED, HINGED, LOCKING LATCH, H-20 TRAFFIC RATED, FULL OPENING, TORSION SPRING ASSISTED, DOUBLE DIAMOND PLATE DOOR, 3'x6' CLEAR OPENING

**PLAN**  
NTS

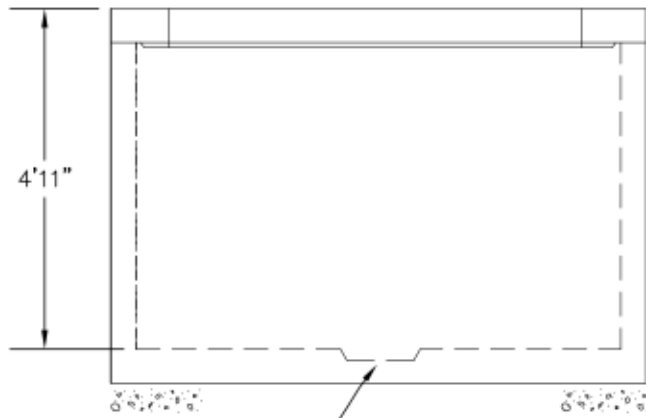

12" DIAMETER SUMP (OPTIONAL)

**SIDE**  
NTS

3" MIN  $\frac{3}{4}$ " MINUS CRUSHED ROCK COMPACTED TO STANDARDS

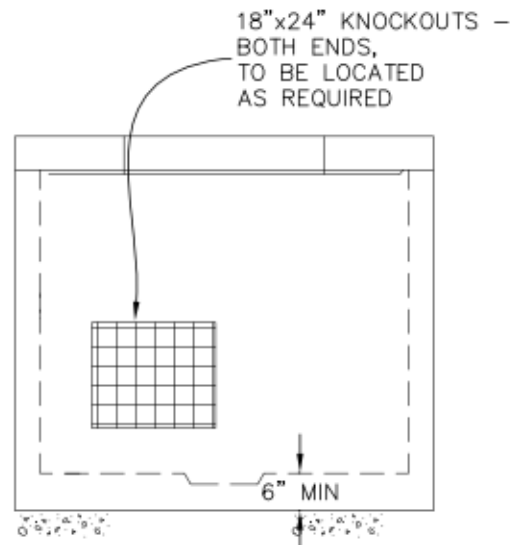

18"x24" KNOCKOUTS - BOTH ENDS, TO BE LOCATED AS REQUIRED

**END**  
NTS

APPROVED VAULTS AND LIDS

1. ALLIANCE CONCRETE ENCLOSURES INC ACE-468 OR ACE-468S FIRE SERVICE VAULT
2. UTILITY VAULT CO. 675-WA VAULT WITH 675-TW-2-332P LID (4" OR 6" DEVICE)
3. UTILITY VAULT CO. 5106-LA VAULT WITH 5106-TL-2-332P LID (8" OR 10" DEVICE)

STRUCTURAL NOTES:

1. CONCRETE: 28-DAY STENGTH F'C=4500 PSI
2. REBAR: ASTM A615 GRADE 60
3. MESH: ASTM A-185 GRADE 65
4. MINIMUM DESIGN PARAMETERS: ASTM C-857 - MINIMUM DESIGN, ACI-318 BUILDING CODE LOADING FOR UNDERGROUND PRECAST CONCRETE UTILITY STRUCTURES

9/22/09 800.DWG



REV	PRECAST NON-TRAFFIC VAULT AND LID
10/09	STANDARD DETAIL NO. 800

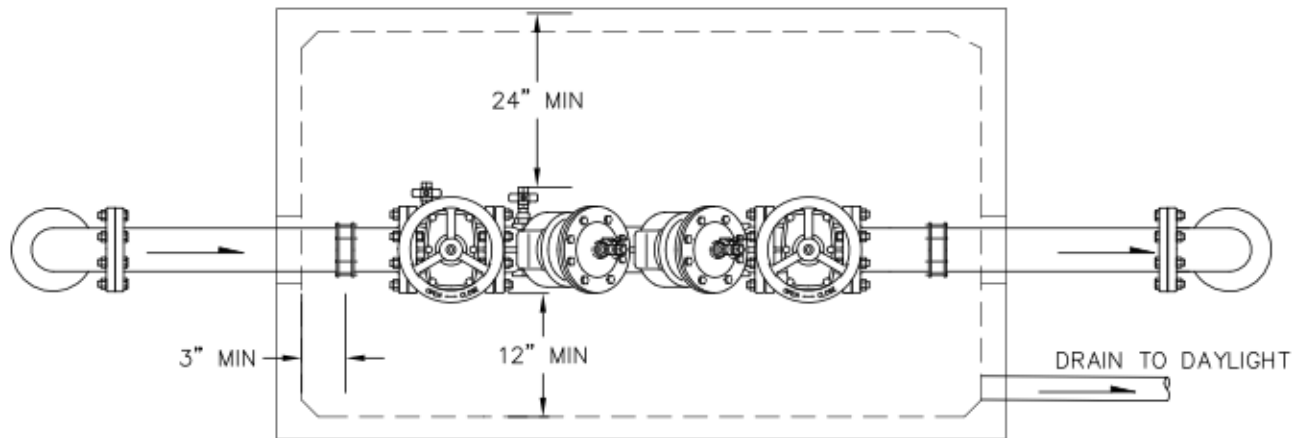

**PLAN**  
NTS

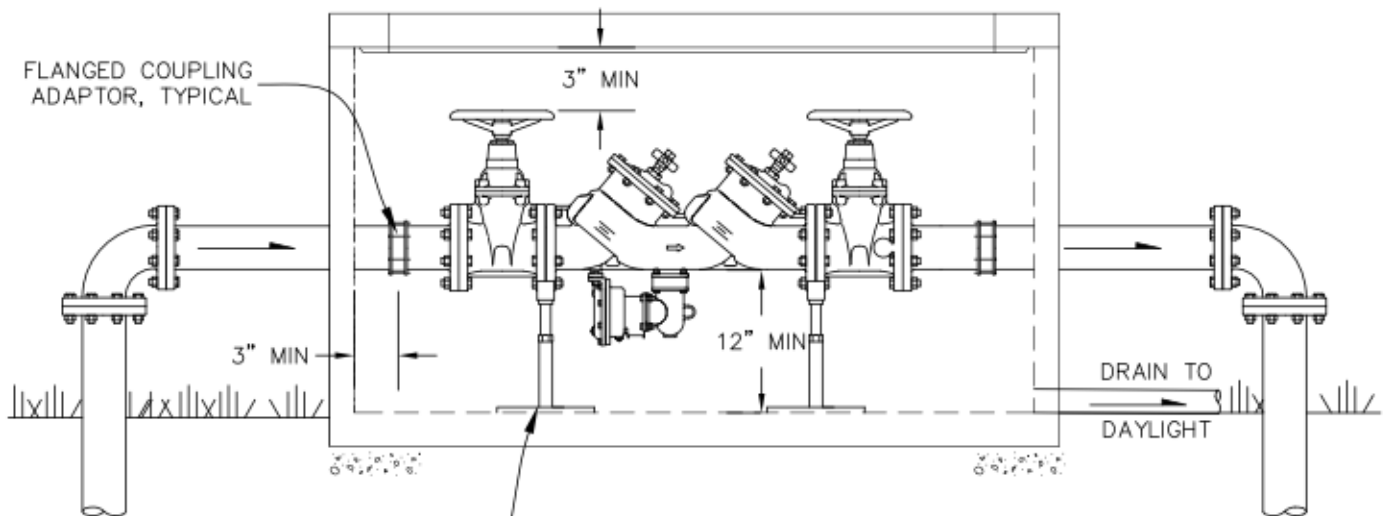

**SIDE**  
NTS

PROVIDE ADJUSTABLE METAL PIPE SUPPORT: GRINNELL FIG 258/FIG 259 OR AS APPROVED

**NOTE:**

1. LARGE ASSEMBLIES ARE THOSE 2½" AND LARGER.
2. ASSEMBLY SHALL NOT BE SUBJECT TO FLOODING.
3. DRAIN LINES SHALL BE SIZED TO ACCOMODATE FULL RELIEF VALVE DISCHARGE FLOW.
4. RP's ARE TYPICALLY INSTALLED ABOVE-GRADE IN WELL-DRAINED AREAS, BUT MAY BE INSTALLED BELOW-GRADE IF AN ADEQUATE DRAIN TO DAYLIGHT IS PROVIDED.
5. RP's SHALL BE INSTALLED ABOVE THE 100 YEAR FLOOD LEVEL, UNLESS OTHERWISE APPROVED BY MWC.
6. BRASS OR PLASTIC PLUGS ARE REQUIRED FOR ALL VAULT INSTALLATIONS.

9/22/09 802.dwg



REV	REDUCED PRESSURE PRINCIPLE ASSEMBLY (RP)
10/09	STANDARD DETAIL NO. 802

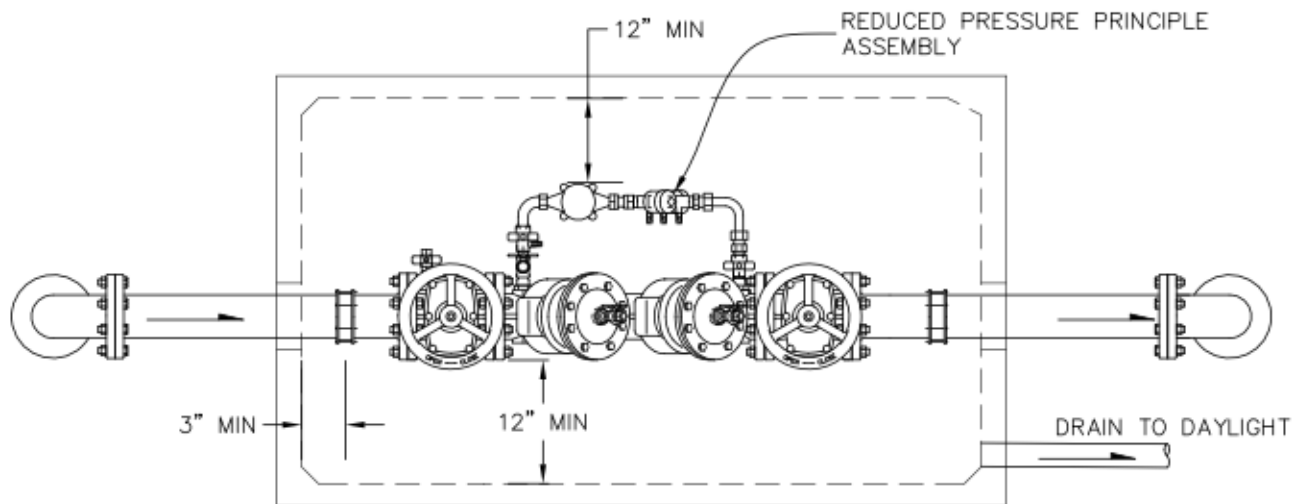

**PLAN**  
NTS

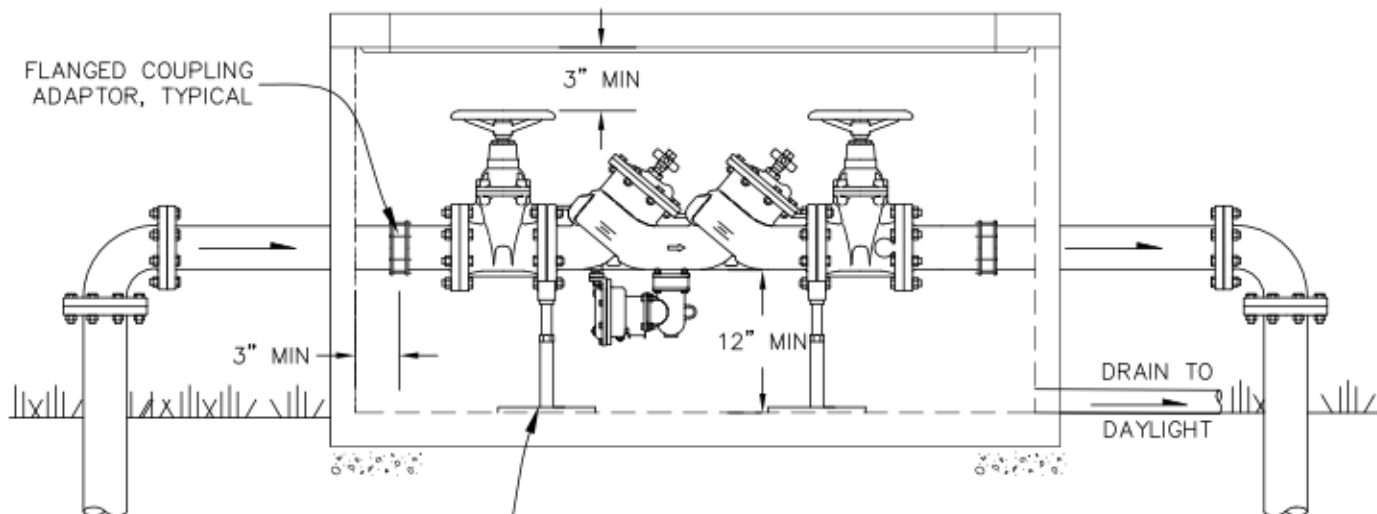

**SIDE**  
NTS

PROVIDE ADJUSTABLE METAL PIPE SUPPORT: GRINNELL FIG 258/FIG 259 OR AS APPROVED

**NOTE:**

1. LARGE ASSEMBLIES ARE THOSE 2½" AND LARGER.
2. ASSEMBLY SHALL NOT BE SUBJECT TO FLOODING.
3. DRAIN LINES SHALL BE SIZED TO ACCOMODATE FULL RELIEF VALVE DISCHARGE FLOW.
4. RPDA's ARE TYPICALLY INSTALLED ABOVE-GRADE IN WELL-DRAINED AREAS, BUT MAY BE INSTALLED BELOW-GRADE IF AN ADEQUATE DRAIN TO DAYLIGHT IS PROVIDED.
5. RPDA's SHALL BE INSTALLED ABOVE THE 100 YEAR FLOOD LEVEL, UNLESS OTHERWISE APPROVED BY MWC.
6. BRASS OR PLASTIC PLUGS ARE REQUIRED FOR ALL VAULT INSTALLATIONS.

9/22/09 803.DWG



REV	REDUCED PRESSURE PRINCIPLE DETECTOR ASSEMBLY (RPDA)
10/09	STANDARD DETAIL NO. 803

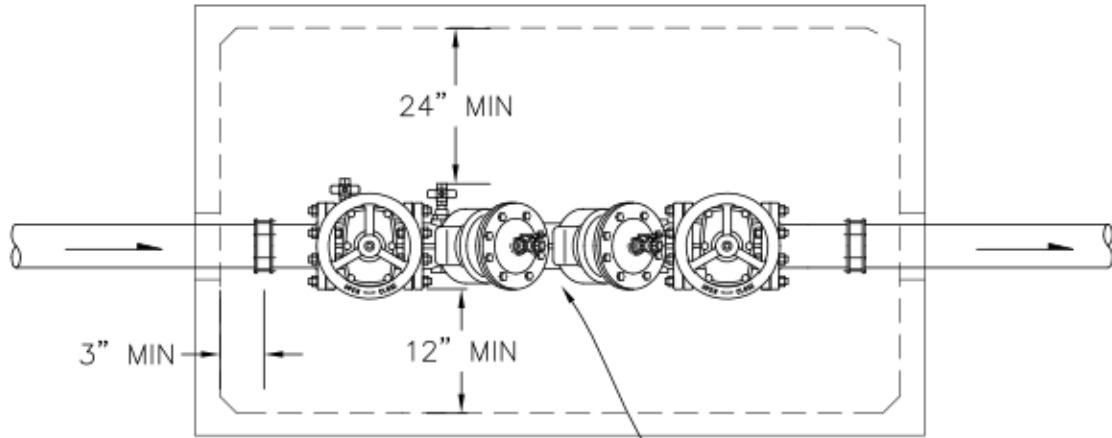

**PLAN**  
NTS

DOUBLE CHECK VALVE ASSEMBLY  
(LARGE)

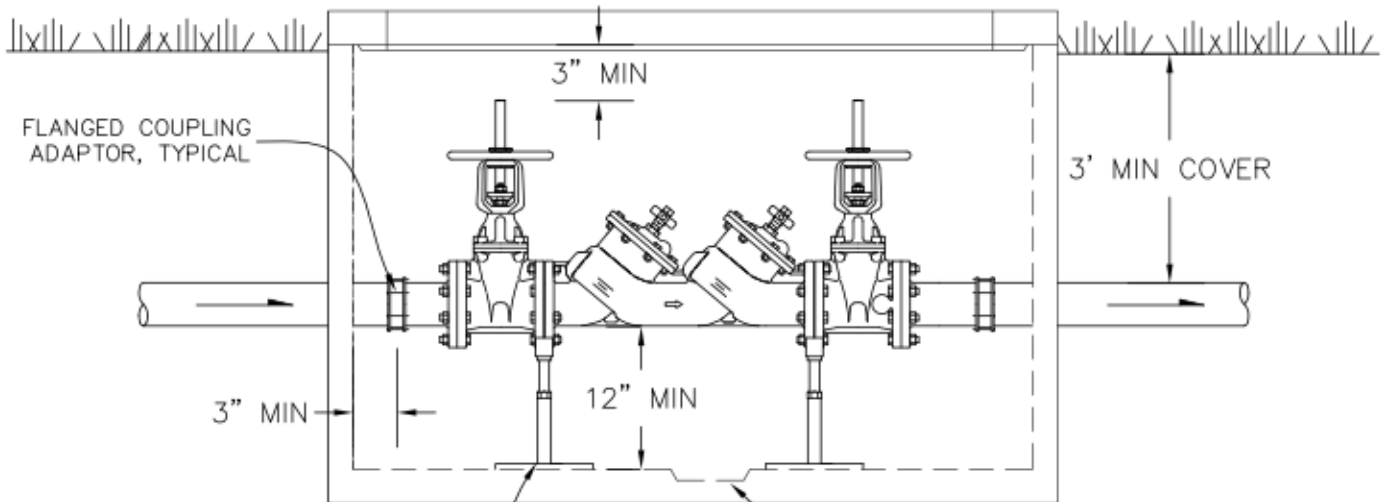

FLANGED COUPLING  
ADAPTOR, TYPICAL

3' MIN COVER

3" MIN

12" MIN

PROVIDE ADJUSTABLE METAL  
PIPE SUPPORT: GRINNELL FIG  
258/FIG 259 OR AS APPROVED

DRAIN SUMP  
(OPTIONAL)

**SIDE**  
NTS

**NOTE:**

1. LARGE ASSEMBLIES ARE THOSE 2½" AND LARGER.
2. ASSEMBLY SHALL NOT BE SUBJECT TO FLOODING.
3. DC'S ARE TYPICALLY INSTALLED BELOW-GRADE.
4. DC'S SHALL BE INSTALLED ABOVE THE 100 YEAR LEVEL, UNLESS OTHERWISE APPROVED BY MWC.
5. BRASS OR PLASTIC PLUGS ARE REQUIRED FOR ALL TESTING PORTS.

805.DWG

9/22/09



REV

DOUBLE CHECK VALVE ASSEMBLY (DC)

10/09

STANDARD DETAIL NO. 805

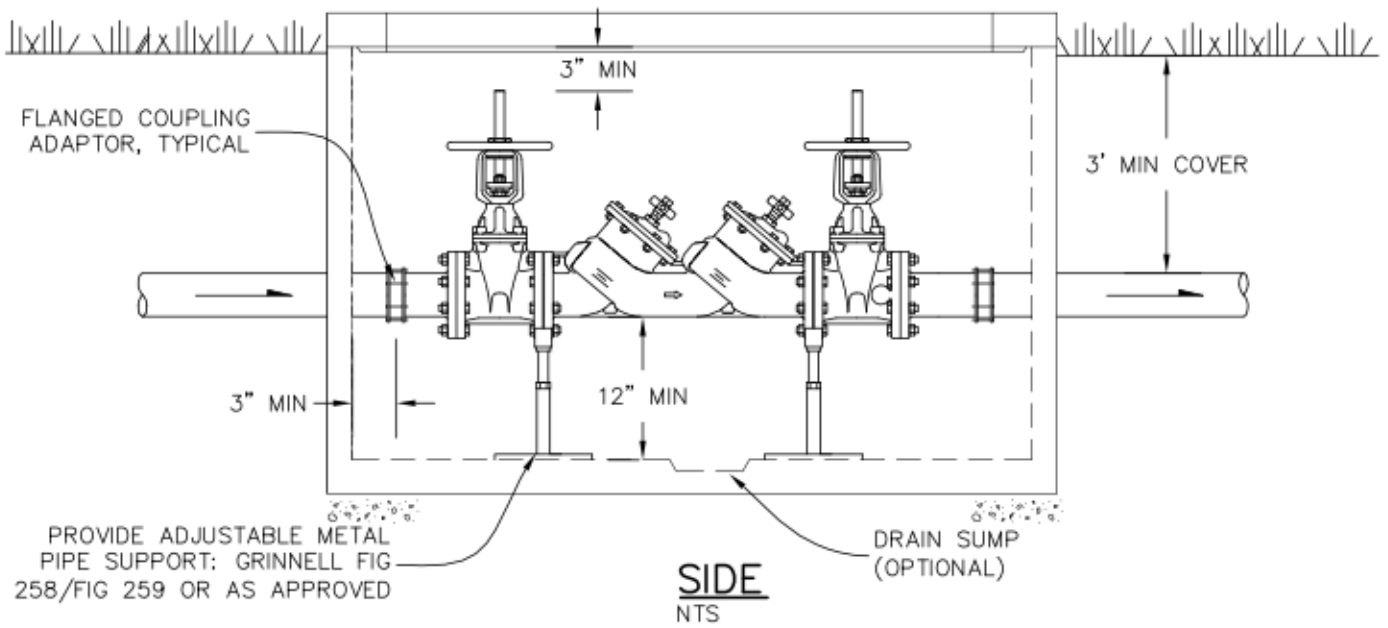
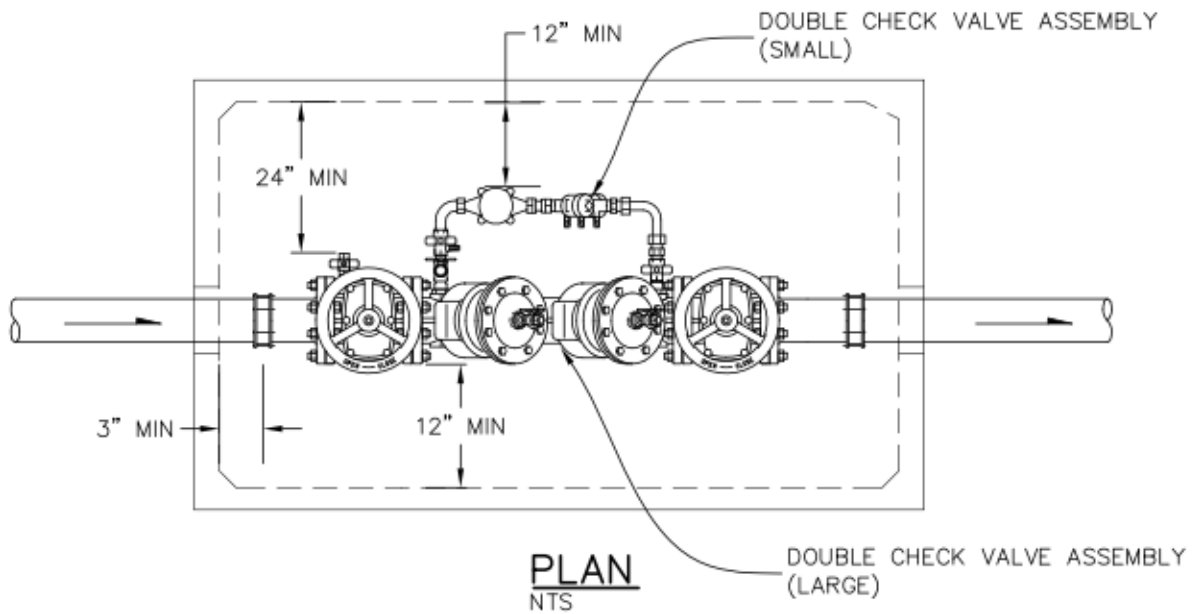

PROVIDE ADJUSTABLE METAL PIPE SUPPORT: GRINNELL FIG 258/FIG 259 OR AS APPROVED

**NOTE:**

1. LARGE ASEMBLIES ARE THOSE 2½" AND LARGER.
2. ASSEMBLY SHALL NOT BE SUBJECT TO FLOODING.
3. DCDAs ARE TYPICALLY INSTALLED BELOW-GRADE.
4. DCDAs SHALL BE INSTALLED ABOVE THE 100 YEAR FLOOD LEVEL, UNLESS OTHERWISE APPROVED BY MWC.
5. BRASS OR PLASTIC PLUGS ARE REQUIRED FOR ALL TESTING PORTS.
6. IF DOMESTIC SERVICE IS INSTALLED OFF THE FIRE SERVICE, A SECOND GATE VALVE SHALL BE INSTALLED OUTSIDE THE VAULT. RESTRAINED JOINTS MUST BE PROVIDED BETWEEN THE VALVE AND THE MAIN.
7. APPROVED DEVICE ASSEMBLIES: ALLIANCE CONCRETE ENCLOSURES, INC. ACE-468 FIRE SERVICE BACKFLOW ASSEMBLY.

9/22/09 807.DWG



REV	DOUBLE CHECK DETECTOR ASSEMBLY (DCDA)
10/09	STANDARD DETAIL NO. 807