

October 17, 2012

(Updated July 1, 2023)

standards

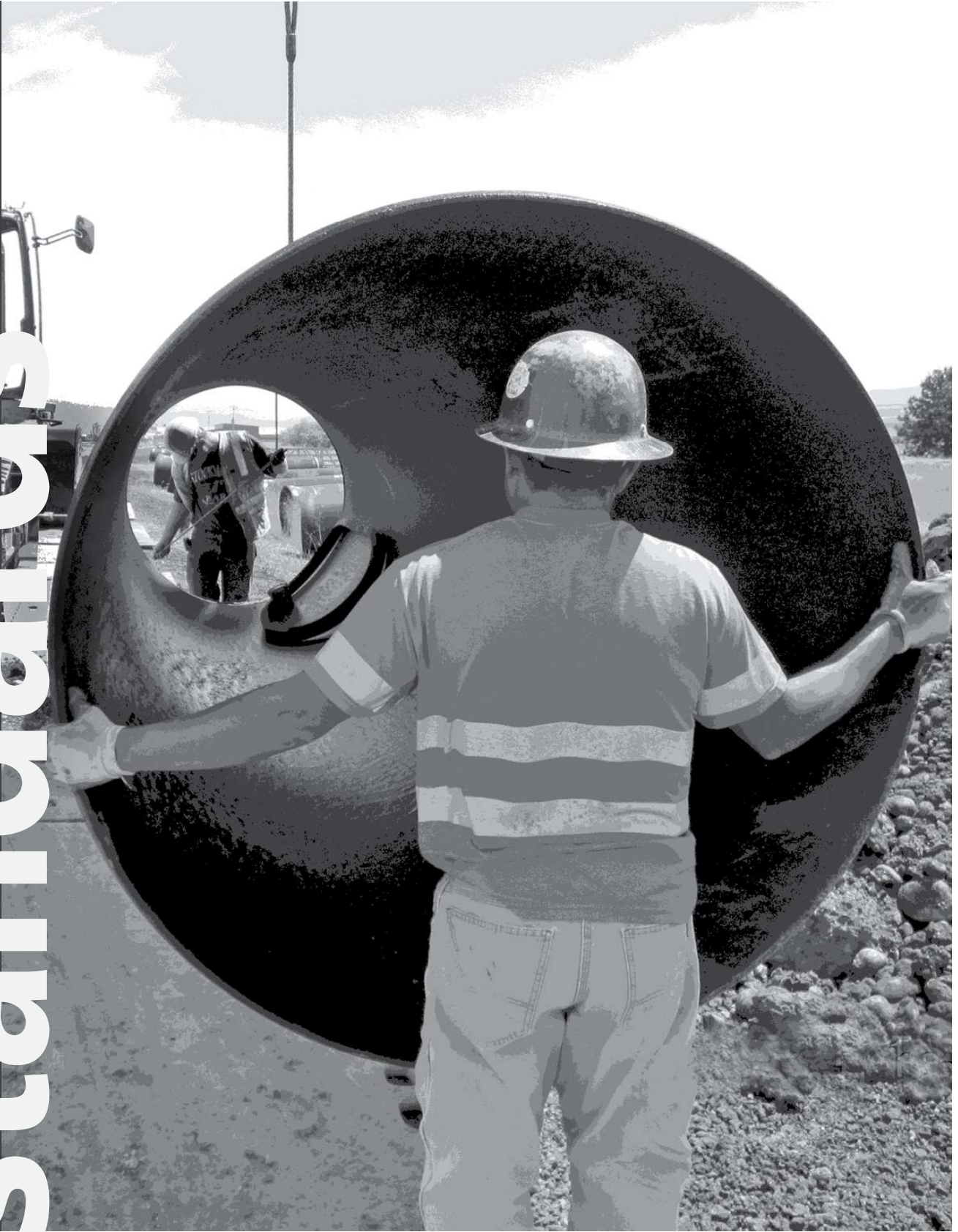

Water Facilities

200 S. Ivy St. - Room 177, Medford, Oregon 97501
541-774-2430 • water@medfordwater.org • medfordwater.org



**JULY 2023 UPDATES TO THE
2012 STANDARDS FOR WATER FACILITIES**

UPDATED SECTIONS

SECTION III GUIDELINES & DESIGN CRITERIA

3.01 Water Mains

3.01.01 Type of Pipe

3.04.01 Type of Meters and Service Lines

SECTION IV STANDARD SPECIFICATION FOR MATERIALS AND INSTALLATION

IIA Standard Specifications for Ductile Iron Pipe, Cast Iron Fittings, Valves, And Fire Hydrants

B-3 Ductile Iron Pipe

B-3.01 through B-3.04

III Standard Specifications for Water Services – Entire Section

SECTION V STANDARD DETAIL DRAWINGS

101 1-Inch Service with 5/8" X 3/4" Meter Setting – Replaced with Standard Details No. 101-A and 101-B

DELETED SECTION

APPENDIX I METER PARTS SUPPLIED LIST

NEW SECTION

SECTION IV STANDARD SPECIFICATION FOR MATERIALS AND INSTALLATION

IV Standard Specifications for Polyethylene Encasement

SECTION V STANDARD DETAIL DRAWINGS

114 Polyethylene Encasement (Polywrap) Detail

TABLE OF CONTENTS

SECTION I CONDITIONS OF ACKNOWLEDGMENT AND AGREEMENT

1.01 DEVELOPMENT AGREEMENT

1.02 REQUIREMENTS

SECTION II GENERAL REQUIREMENTS

2.00 GENERAL

2.00.01 Description

2.00.02 Responsible Party

2.01 PLANS

2.01.01 Plan Submittal

2.01.02 Plan Details

2.01.03 General Notes

2.02 CONTROL OF WORK

2.02.01 Scope of Work

2.02.02 Control of Work

2.02.03 Inspection

2.02.04 Approval of Contractor, Pipeline Install and Service Installer

2.02.05 Construction

2.02.06 Materials

2.02.07 Permits

2.02.08 Coordination of Plans, Specifications, and Special Provisions

2.02.09 Lines and Grades

2.02.10 Safety

2.03 COMPLETION

2.03.01 Completion

SECTION III GUIDELINES & DESIGN CRITERIA

3.00 GENERAL

3.00.00 Description

3.00.01 State of Oregon Requirements

3.00.02 Existing Water Mains and Water Facilities

3.00.03 Proposed Design of Water Facilities

3.01 WATER MAINS

- 3.01.00 Description
- 3.01.01 Type of Pipe
- 3.01.02 Size of Pipe
- 3.01.03 Location of Pipe
- 3.01.04 Over-sizing of Pipe
- 3.01.05 Full Property Frontage Extension of Pipe
- 3.01.06 Depth of Cover
- 3.01.07 Connections to Existing Pipes
- 3.01.08 Looping of Pipes
- 3.01.09 Separation Between Pipes
- 3.01.10 Plugging and Capping of Pipe
- 3.01.11 Thrust and Anchorage Blocks
- 3.01.12 Mechanically Restrained Joints
- 3.01.13 Deflection of Pipe
- 3.01.14 Grade for Pipe
- 3.01.15 Poly Pigs
- 3.01.16 Pipe Piers
- 3.01.17 Crankshafts in Water Mains
- 3.01.18 Flex-Tends
- 3.01.19 Dry Line Pipe

3.02 VALVES

- 3.02.00 Description
- 3.02.01 Type of Valve
- 3.02.02 Size of Valve
- 3.02.03 Location of Valve
- 3.02.04 Spacing of Valve
- 3.02.05 Valve Cans and Lids
- 3.02.06 Special Crossings

3.03 FIRE HYDRANTS

- 3.03.00 Description
- 3.03.01 Fire Hydrants
- 3.03.02 Type of Fire Hydrants
- 3.03.03 Size of Fire Hydrants
- 3.03.04 Location of Fire Hydrants
- 3.03.05 Spacing of Fire Hydrants
- 3.03.06 Protection of Fire Hydrants
- 3.03.07 Separation of Facilities

3.03.08	Fire Hydrants Dedicated for Fire Department Connections (FDC)
3.03.09	Fire Hydrant Maximum Length
3.03.10	Existing Fire Hydrants
3.04	METERS & SERVICE LINES
3.04.00	Description
3.04.01	Types of Meters and Service Lines
3.04.02	Sizes of Meters and Service Lines
3.04.03	Location of Meters and Service lines
3.04.04	Protection of Meters
3.04.05	Separation of Facilities
3.04.06	Metering for Development
3.04.07	Remote Metering and Sub-metering
3.04.08	Backflow
3.05	AIR VALVES
3.05.00	Description
3.05.01	Type of Air Release Valves
3.05.02	Sizes of Air Release Valves
3.05.03	Location of Air Release Valves
3.05.04	Protection of Air Release Valves
3.05.05	Separation of Facilities
3.05.06	Insulation of Air Release Valves
3.06	BLOW-OFFS
3.06.00	Description
3.06.01	Type of Blow Offs
3.06.02	Sizes of Blow Offs
3.06.03	Location of Blow Offs
3.06.04	Protection of Blow Offs
3.06.05	Separation of Facilities
3.07	CASINGS
3.07.00	Description
3.07.01	Casing Required
3.07.02	Type of Casing
3.07.03	Water Facility in Casing
3.08	SLOPES
3.08.00	Description
3.08.01	Water Facilities in Slopes
3.09	ABANDONMENTS
3.09.00	Description

- 3.09.01 Abandonments
- 3.09.02 Work Performed by MWC

3.10 EASEMENTS AND MAPS

- 3.10.00 Description
- 3.10.01 Location of Easement
- 3.10.02 Size of Easement
- 3.10.03 Restriction of Easement
- 3.10.04 Writing of the Easement
- 3.10.05 Illustrating the Easement
- 3.10.06 Recording the Easement
- 3.10.07 Access Road for the Easement
- 3.10.08 Maps
- 3.10.09 Domestic Water Service not Provided
- 3.10.10 Correction to Recorded Easement
- 3.10.11 Easement for Water District

3.11 FIRE SERVICES

- 3.11.00 Description
- 3.11.01 Fire Service
- 3.11.02 Type of Fire Service
- 3.11.03 Size of Fire Service
- 3.11.04 Location of Fire Service
- 3.11.05 Requirements of Fire Services
- 3.11.06 Abandonment of Fire Service
- 3.11.07 Fire Service to Multiple Buildings

3.12 COSTS & SYSTEM DEVELOPMENT FEES

- 3.12.00 Description
- 3.12.01 Project Fees
- 3.12.02 System Development Fees
- 3.12.03 Meter Fees
- 3.12.04 Abandonment of Existing Meter Fee
- 3.12.05 Street Moratorium Fee
- 3.12.06 Transfer of System Development Fee
- 3.12.07 Fees for Water Meters to Lots Not Created
- 3.12.08 Fee for Night Work
- 3.12.09 Existing Lots in SDC Fee Area

3.13 PRIVATE PUMPS

- 3.13.00 Description
- 3.13.01 Private Pump System
- 3.13.02 Requirements for Private Pump System

3.14 PRESSURE ZONES

- 3.14.00 Description
- 3.14.01 Location of Pressure Zones
- 3.14.02 List of Pressure Zones
- 3.14.03 Design Consideration of Pressure Zones

3.15 TESTING & DISINFECTION

- 3.15.00 Description
- 3.15.01 Pressure Testing of Water Mains
- 3.15.02 Disinfection of Water Mains

3.16 WATER DISTRICTS

- 3.16.00 Description
- 3.16.01 Location of Water Districts
- 3.16.02 Approval of Plans by Water District

3.17 BIG BUTTE SPRINGS WATER TRANSMISSION MAINS

- 3.17.00 Description
- 3.17.01 Location of BBS Water Transmission Mains
- 3.17.02 Activities around BBS Water Transmission Mains

SECTION IV STANDARD SPECIFICATION FOR MATERIALS AND INSTALLATION

I STANDARD SPECIFICATIONS FOR TRENCH EXCAVATION AND BACKFILL

IIA STANDARD SPECIFICATIONS FOR DUCTILE IRON PIPE, CAST IRON FITTINGS, VALVES, AND FIRE HYDRANTS

IIB STANDARD SPECIFICATIONS FOR STEEL PIPE AND FITTINGS, AN ALTERNATE PIPE FOR TRANSMISSION MAINS 42- INCHES AND LARGER

III STANDARD SPECIFICATIONS FOR WATER SERVICES

IV STANDARD SPECIFICATIONS FOR POLYETHYLENE ENCASEMENT

SECTION V STANDARD DETAIL DRAWINGS

DETAIL DRAWINGS

- 100A Meter Installation and Location (General)
- 100B Single Family Service Installation (Medford)
- 100C Water Facility Location (General)
- 100D Water Facility Location (White City)

101-A1	1" Service with 5/8" x 3/4" Meter Setting
101-A2	1" Service with 5/8" x 3/4" Meter Setting Approved Materials
101-B1	1" Service with 1" Meter Setting
101-B2	1" Service with 1" Meter Setting Approved Materials
102	Sample and Disinfection Tree
103	Full Size Flush Point
104	Hydrant Installation for 14-Inch Main and Smaller
105	Hydrant Installation for 16-Inch Main and Larger
106	1-Inch Air Valve
107	2-Inch Air Valve
108	Mainline Blowoff Assembly
109	Thrust Blocks
110	Casing Detail
111	Typical Trench Detail
112	Bollard Detail
113	Support Pier Detail
114	Polyethylene Encasement (Polywrap) Detail

APPENDIXES

APPENDIX A	SAMPLE EASEMENTS FORM – INDIVIDUAL
APPENDIX B	SAMPLE EASEMENTS FORM – CORPORATION
APPENDIX C	SAMPLE QUITCLAIM FORM – MWC
APPENDIX D	SAMPLE EXHIBIT ‘A’ LEGAL DESCRIPTION – WRITTEN
APPENDIX E	SAMPLE EXHIBIT ‘B’ LEGAL DESCRIPTION – ILLUSTRATION
APPENDIX F	SAMPLE DEDICATION AND DECLARATION OF ACCEPTANCE OF WATER SYSTEM FACILITIES
APPENDIX G	PROCEDURES CHECK LIST
APPENDIX H	RESPONSIBLE PARTY FORM

SECTION I

CONDITIONS OF ACKNOWLEDGMENT AND AGREEMENT

1.01 DEVELOPMENT AGREEMENT

The following conditions apply to the Statement of Acknowledgment and Agreement signed by the developer for any given project.

Pursuant to the fee letter being issued to the Developer by Medford Water Commission (MWC) the following is verbatim from the fee letter:

Water mains and appurtenances IF installed across private property must be provided with a WRITTEN easement dedicated to the MWC by the owner. These easements do not allow building of any structures over them now or in the future.

Prior to the final project being approved and accepted, the owner is responsible for signing a MWC Dedication and Declaration Form, which also specifies actual costs of the water facilities installation.

PLEASE NOTE THAT THIS PROJECT CANNOT PROCEED UNTIL WRITTEN APPROVALS FROM OTHER AGENCIES ARE RECEIVED, PRE-DESIGN MEETING IS HELD, CORRECTION SET AND FINAL COPIES OF PLAN CORRECTIONS AND DISK HAVE BEEN SUBMITTED, ESTIMATES/FEES/CHARGES ARE PAID, SIGNED EASEMENTS SUBMITTED, AND STATEMENT OF ACKNOWLEDGMENT SIGNED.

Please have the following statement signed:

I, as the owner, developer, or contractor of the above noted project, acknowledge that the above-letter and listed items are required for a complete project with the MWC and I agree to take responsibility to guarantee that all requirements reflected here and elsewhere in the MWC standards and regulations are adhered to. I have read, understand, and agree to the Conditions of Acknowledgment and Agreement contained in Section I of the Standards for Water Facilities Booklet (green) of the MWC.

Signature

Date

Print name

1. Water mains and appurtenances, if installed across private property, must be provided with a written easement dedicated to MWC by the owner. These easements do not allow building of any structures over them now or in the future. All signed (by owner) and notarized easements on MWC standard forms are required prior to approval of construction plans.
2. The owner must supply the MWC with a statement of actual construction costs of the water facilities and must complete and sign a form for the *Dedication and Declaration of Acceptance of Water System Facilities* at the end of the project. The one-year warranty on the water facilities guaranteed by the owner does not start until this dedication is signed.

1.02 REQUIREMENTS

1. All utility/entity appurtenances and routing locations will be shown, coordinated and signed off. The required procedure for this coordination will be through a

UTILITY PRE-DESIGN meeting with all utilities/entities (power, telephone, natural gas, cable TV, engineer, architect, surveyor, water district, irrigation district, owner, developer, public works departments, etc.) including MWC and the controlling Fire Department.

FIRE HYDRANTS, WATER METERS, AND OTHER WATER-RELATED ITEMS WILL BE LOCATED ON PLANS SUCH THAT THERE ARE NO CONFLICTS WITH OTHER UTILITY APPURTENANCES OR DRIVEWAYS. PLEASE NOTE THAT THE MWC STANDARD IS 5' CLEAR FROM WATER FACILITY APPURTENANCES. SINGLE AND NON-STANDARD DOUBLE WATER METERS WILL BE STATIONED OR DIMENSIONED ON PLANS FOR CONSTRUCTION STAKING AND INSPECTION VERIFICATION. THE RESPONSIBILITY FOR THE OUTCOME OF THIS PRE-DESIGN MEETING AND CONFLICT-FREE APPURTENANCE LOCATIONS IS THAT OF THE DEVELOPER AND THEIR DESIGN ENGINEER.

2. The developer and engineer will understand that the standards and regulations imposed by the MWC are minimum requirements and that it will be the design engineer's responsibility to guarantee the safety and performance of their design beyond these requirements. It is also required that the registered engineer that stamps the plans submitted for approval be responsible not only for the adequacy of design but proper implementation of the design throughout the project. This includes proper surveying, staking, and inspection, providing of record information, AND solving problems that may occur during construction. MWC realizes that some of these duties may be assigned to others; however MWC will look to the registered design professional engineer for responsibility of conformance to plans and design performance.
3. The estimated cost for plan check includes, but is not limited to such things as plan review, preconstruction meeting, temporary water services when needed, valve operation, MWC service crew work, special welded sleeves or material, labor and equipment charges for mainline taps, inspection, flushing, testing, disinfection, dechlorination, sampling, bacteriological tests, project finalization, fire hydrant painting, minor materials, and record drawings. The contractor provides all the pipeline and material appurtenances (unless noted otherwise), excavation, installation of the pipeline, backfill, and surfacing.

The contractor is responsible for contacting engineering or public works departments of all other jurisdictional agencies and for obtaining all required permits.

4. Please keep in mind that the plan check amount is an estimate, and if additional work is incurred, it will be charged to the developer. If the work is not as extensive as estimated, a refund will be made to the developer. The developer is the one who pays the initial estimated cost. The developer will be completely responsible for ensuring prompt payment of all additional costs incurred whether they paid the initial estimated cost or not. The final billing statement could be delayed after actual completion of the water related project because of reasons beyond the control of the MWC. This charge or refund is not processed until the project is final with MWC, which includes final paving of finished surfaces. The charge or refund may take four to six weeks to process.

5. Conflicts with unknown existing facilities encountered may cause additional work and added costs to the project of which the developer will be completely responsible for to ensure proper construction to current MWC standards.
6. All estimates, fees and charges must be paid prior to any work being done by MWC.
7. The following items should be noted:
 - a) The developer's representative, engineer and/or contractors will arrange a preconstruction conference on the site with the MWC engineering division at least 48 hours prior to start of the project. Please note that during the busy construction seasons, it very likely will be necessary to abide by and allow this lead time notice as well as the time requirements for scheduling.

ABSOLUTELY NO WORK WILL BE DISCUSSED, SCHEDULED OR ACCOMPLISHED BY MWC UNTIL THIS CONFERENCE IS HELD. YOU MAY CONTACT ENGINEERING INSPECTION STAFF: (541) 774-2438 TO ARRANGE THE CONFERENCE. PLEASE DO NOT CONTACT ANY OTHER MWC EMPLOYEES REGARDING THESE ARRANGEMENTS.

All phases of construction will require inspection and approval by MWC before covering up or backfilling.

- b) The contractor, foreman and pipe layer will be prequalified with MWC.
- c) The final stamped "approved" construction plans and "green book" MWC Standards will be available at the project at all times during construction.
- d) Be aware that water service may not be allowed until the project is completely final by MWC and any water systems repairs are made. This includes, but is not limited to, all types of project construction that may affect the water system facilities (e.g., power and other utility trenches, paving, any outstanding or remaining billings to be paid, and delivery of the dedication of the water system to the MWC).
- e) Planning and timing for service crew work performed by MWC personnel (e.g., sleeves, taps, testing, disinfection, dechlorination, services, air valves, etc.) must be scheduled ahead of time and preferably with a minimum of two weeks lead time. Some material supplied by MWC may have long lead times in ordering and preparing for this project. This means that all items needed to allow this project to proceed, especially payment of required fees, must be done as soon as possible.

It is the developer's responsibility to provide these items as soon as possible and the contractor's responsibility to schedule service work with the inspector ahead of time as noted.

All service work will be scheduled through the inspector, and if the contractor is not prepared at the time of scheduling, then the work goes to the bottom of the list and is rescheduled.

At the time of the preconstruction meeting the inspector will reiterate the scheduling requirements, the level of contractor work to be done ahead of time, and the flow of information during construction.

SECTION II

GENERAL REQUIREMENTS

2.00 GENERAL

2.00.01 DESCRIPTION

1. These standards are for the purpose of establishing standard procedures for developing water facilities design and for constructing water facilities which will become a part of the MWC distribution system, including water districts and other entities contracting with the MWC for service.
2. The provisions of these requirements and specifications shall be made, by reference and inclusion, a part of construction requirements to the extent of their applicability and shall prevail over any other specification provisions.
3. No approval of variances from these guidelines or written estimates of costs will be given prior to submittal of plans for review.
4. Whenever the following terms are used in these requirements, specifications, and special provisions, they are to be interpreted as being synonymous with the accompanying full title:

<u>TERMS</u>	<u>FULL TITLE</u>
MWC	Medford Water Commission
City	City of Medford
Contractor	Firm or corporation contracting with the developer to perform the work; Contractor and the person installing the pipe must be prequalified.
Council	City Council of Medford, Oregon
County	County of Jackson
Developer	Individual, partnership, firm or corporation proposing construction of water facilities which are a planned extension to the existing MWC system
Engineer	Consulting engineer for the developer
Engineering Division	Engineering Division of MWC
Inspector	Inspector for the MWC
Manager	Manager of the MWC
Responsible Party	Individual, partnership, firm or corporation proposing construction of water facilities which are a planned extension to the existing MWC system
State	State of Oregon
Surveyor	Surveyor for the developer

2.00.02 RESPONSIBLE PARTY

The 'Responsible Party' form found in the appendix of these Standards shall be filled out completely and on file with MWC prior to any work starting on the project.

2.01 PLANS

2.01.01 PLAN SUBMITTAL

1. The developer shall submit one (1) full set of prints of the proposed project for 1st plan check, 2nd plan check and 3rd plan check. The Engineering Division will check the drawings and return the drawings (redlines) to the Engineer for corrections. The Engineer will address the corrections and resubmit the corrected drawings and the first plan check comments to MWC for further plan check if required. All previous redlines must be submitted to MWC at time of re-submittal for plan check.
2. Upon completion of plan check, The Engineering Division will issue a fee letter with an estimate of charges for plan check, work to be performed by MWC (such as tapping, inspection, flushing, testing, disinfection, sampling, and record drawings, etc.), and notify the developer via their Engineer of the amount to be deposited. The plans must be approved and signed by the City of Medford, Public Works Department, and City Engineer prior to MWC approving the plans. If the project lies in the County and /or ODOT right of way, then the plans must be approved by those agencies prior to MWC approval.
3. The Developer and Engineer will incorporate any necessary corrections and furnish the MWC with an electronic disk of the final drawings in the latest AUTODESK DWGformat, and two (2) full printed sets of final drawings and three (3) additional sets of prints of the water improvement plans only. Plans that are for fire services shall submit two (2) full printed sets of final drawings and four (4) additional sets of prints of the water improvement plans only. Final printed plans shall be at full scale on 24" by 36" paper.
4. Signed and notarized easement shall be provided for recordation.
5. The fee deposit as outline in the development agreement shall be paid in full to MWC.
6. The owner will be requested at this point to sign a development agreement, acknowledging those responsibilities required of them for finalization and acceptance of the water facilities.
7. Upon receipt of the plans, electronic files on CD, easements, fees and development agreement, the Engineering Division will initiate a work order, and return two (2) sets of drawings marked "Approved" to the contractor at a pre-construction meeting.

8. Approval of plans by MWC shall expire one year from the approval date. Approved plans become void if the design changes. Changes to the approved design requires resubmittal of the plans for review and approval. Plans that have been approved (fees not paid and work order not issued) by MWC, but have not been constructed within one year of approval will be returned to the Engineer of record. Resubmittals of updated plans are required for the project to move forward.

2.01.02 PLAN DETAILS

The following standards are outlined for general use in preparing plan and profile drawings of water facilities for MWC.

1. All plans are to be prepared and signed by a registered engineer in the State of Oregon.
2. All plans are to be drawn on 24" x 36" sheet. All plans shall be drawn to scale. The scales for the plan view shall be engineering scales of: 1" to 50', 1" to 40', 1" to 30', 1" to 20' and 1" to 10'. The scales for the profile view shall be engineering scales of: 1" to 5', 1" to 4', 1" to 3', 1" to 2" and 1" to 1'. Details on the plans may use smaller scales if required. Architectural scales are not allowed for engineering drawings.
3. Vicinity Map of the project area shall be provided showing proposed installations in relation to nearest cross streets.
4. Project name, north arrow and bar scales shall be shown on the plans.
5. Plan View: Sizes and materials of existing and proposed water mains, valves, fitting, service lines, meters, fire hydrants and all other water appurtenances shall be shown in plan views. Stationing and offsets of all water facilities (i.e., mains, fittings, fire hydrants, meters, etc.) shall be shown on the plans. Easements shall be shown and dimensioned on the plans. Lot numbers and street names shall be shown on the plans. All existing and proposed utilities shall be shown and dimensioned on the plans. Street improvements including driveway approaches shall be shown on the plans.

Street centerline stations shall be used as reference stationing for water mains, fire hydrants, valves, fittings, and water service connections. Where water mains cannot be referenced to or deviate from street centerline stationing, dimensions for length shall be indicated on the plan view.

Pressure zones and building pad/finish floor elevations shall be shown on plans when there are multiple pressure zones in a project.

MWC general notes shall be shown on all plans.

Construction notes shall be shown on all plans. Construction notes shall address both existing and proposed water facilities and any item effecting water facilities.

Any item that would add to the clarity and constructability to the plan should be shown.

6. Profile View: Profiles of pipeline invert and soffit are to be plotted directly below the plan views. The existing and/or proposed street profile shall be used for final grade to base the water main profile on.

Sizes of water mains, types of classes of pipes, air release valves, length of restraint pipe, casings and backfill classifications are to be shown in the profile view.

Stationing and grades (elevations) of pipes are to be shown in the profile view. Stationing and grades (elevations) of grade break in pipes alignment are to be shown in the profile view.

All utility crossings (i.e., sanitary sewer, storm drain, irrigation pipes, existing water mains, electrical, natural gas, telephone, fiber optic, etc.) are to be shown and labeled in the profile view.

Any item that would add to the clarity and constructability to the plan should be shown in the profile view.

2.01.03 GENERAL NOTES

1. The following general note shall appear on every plan: "All water works shall be done in accordance with the current requirements of the MWC's Standard Specifications"
2. The following notes should appear once on the plans, but in any case apply to all sheets:
 - a. Service connections are to be installed for each parcel per MWC standards (Standard Details Nos. 100A, 100B, 100C and 100D).
 - b. Cover over existing mains shall not be changed without written authorization of MWC.
 - c. New mains are to be pressure tested, disinfected and proven to be bacteriologically safe prior to placing new mains in service by the MWC. Pressure testing shall not be done until all excavation and backfill up to subgrade has been established.

- d. Initial backfill to top of water mains and fire hydrants runs shall be compacted in accordance with MWC Standard Specification for trench Excavation and Backfill, or backfill material and compaction shall meet the requirements of the controlling agency.
- e. Water mains and fire hydrants are to be installed with reference alignment and grade status and only upon notification of the MWC Inspector.
- f. Water mains are to be installed after sewers.
- g. Fire hydrant runs are to be installed before curbs and gutters. In the event a water main is installed larger than eight inches (8"), or if the main has more than three feet (3') of cover, the contractor will be required to install an offset similar to Standard Detail 105 to permit use of a standard three to six-foot (3'-6') bury fire hydrant.
- h. Stubs service runs shall be installed prior to curb and gutter and after PUEs are graded to curb levels.
- i. Approved plans and specification shall be available at site of construction at all times during construction of water facilities.
- j. Copies of the MWC's Standard Specification can be obtained at the office of MWC.
- k. Separation of water main, including service lines and sanitary sewer, shall be in accordance with current Oregon State Health Division Rules and /or as modified in Section IV, Item II, C-8 of these Standards except in all cases running parallel with each other, there shall be a 10-foot (10') separation center line to center line.
- l. No above-ground appurtenances or physical structures of any kind shall be within five feet (5') (horizontally) of any water facility whether that water facility is above or below ground. This distance shall be ten feet (10') (horizontally) when water and sanitary sewer facilities are concerned.
- m. No below-ground utility lines or other service of any kind shall be within five feet (5') (horizontally) of any water facility when running parallel to the water facility.
- n. No below-ground utility lines or other service of any kind shall be within six inches (6") (vertically) of any water facility when running approximately perpendicular to the water facility. This distance shall be

eighteen inches (18") (vertically) when water and sanitary sewer facilities are concerned.

- o. Blasting or explosive work will not be allowed within 30 feet (30') of existing water facilities and only then using proper industry standards and through a permit process with the Fire Department or other agency jurisdiction.
- p. MWC requires "poly pigs" to be used on all newly laid water lines.
- q. All dry tap water services and air release valves shall be installed by a MWC pre-qualified installer.
- r. Only State of Oregon-approved backflow prevention assemblies shall be installed.

2.02 CONTROL OF WORK

2.02.01 SCOPE OF WORK

1. It is the developer's responsibility to have all work done in accordance with approved plans and MWC Standard Specifications.
2. Any change or alteration in approved plans will require written consent of the Engineering Division.
3. MWC will assist in marking and locating MWC facilities through the Oregon Utility Notification Center system.

2.02.02 CONTROL OF WORK

1. The Engineering Division will decide all questions which may arise as to the quality of acceptability of materials furnished and work performed. The Engineering Division will have the authority to decide on the acceptable fulfillment of all phases of work.
2. Finished construction shall conform to grades and dimensions shown on approved plans. Deviations from approved plans, as may be required by the necessities of construction, will be determined in all cases by the Engineering Division and significant deviations must first be authorized in writing.
3. Construction not included as part of the original plans must first be given written approval by the Engineering Division.
4. Failure to comply with the aforementioned requirements will be cause for rejection of the work.

2.02.03 INSPECTION

1. MWC's Inspector shall at all reasonable times have access to the work during construction and shall be furnished every reasonable facility for ascertaining full knowledge regarding adherence to plans, workmanship and type, and quality of materials used in the work.
2. Work which is defective in its construction or deficient in any of the specified requirements shall be removed and replaced to the satisfaction of MWC.
3. Failure to comply with any part of the plans may be sufficient cause to reject the work. Deviations will be called to the attention of the developer or contractor at the time it is noted. Failure to comply by making the necessary corrections will result in the sending of a written notification to the Engineer, the Contractor and the Developer, that any work thereafter will not be accepted until after corrections have been made to the satisfaction of MWC.

2.02.04 APPROVAL OF CONTRACTOR, PIPE INSTALLER AND SERVICE INSTALLER

1. The contractor and person installing the pipe and water facilities shall be approved by MWC. Calendar year prequalification information shall be submitted on MWC "Contractor Prequalification Application" forms.

The Contractor must list previous work related to "Ductile Iron Pipe Installation" or other items related to particular projects, with references and telephone numbers.

The Contractor may be required to attend a meeting with MWC field personnel with their service truck and explain their planned approach to the project as well as knowledge of our printed standards. Determination of prequalification may be based solely on this information.

It must be understood that the MWC inspects waterline work for acceptance into the public system but does not teach the techniques for proper installation. Having the knowledge of techniques for proper installation is the responsibility of the contractor to already possess. New persons wanting to learn the process should work under an experienced Contractor and then apply for prequalification keeping in mind their first few jobs will necessitate increased inspection time until a sense of confidence is achieved by MWC.

Work performed by other than approved contractors and people installing the water facilities will not be accepted.

2.02.05 CONSTRUCTION

1. All material and workmanship utilized in the construction of facilities that MWC assumes ownership of shall be in accordance with the attached "Standard Specifications for Trench Excavation, Backfill and Shoring" and "Ductile Iron Pipe, Cast Iron Fittings, Valves, and Fire Hydrants."
2. Facilities shall be installed in strict accordance with approved plans.
3. MWC shall be notified 48 hours in advance of construction.
4. All materials and workmanship in the construction of water facilities that MWC assumes ownership of shall be guaranteed for a period of one year following date of acceptance by MWC.
5. Approved Plans shall be available at the site of construction at all times during construction.
6. Prior to backfill operations, water facilities installation shall be inspected by the MWC Inspector to ensure compliance with the plans and specification. Contractor shall notify MWC 48 hours in advance for inspections.
7. It shall be the contractor's responsibility to arrange for inspection prior to backfilling operations.
8. Contractor shall provide excavation, backfill, shoring, surfacing, trench plates, traffic control and etc. when assisting MWC forces.
9. Work activities on water projects shall be confined to normal MWC working hours (8 a.m. to 5 p.m. – Monday through Friday).

2.02.06 MATERIALS

1. All materials shall be new and meet the specified requirements. No other materials will be accepted. All material shall be as listed in the Standard Specifications or as approved by MWC.
2. MWC will refuse to accept for use any materials which are defective or damaged. Installation of any such materials will result in rejection and subsequent request for removal and replacement before acceptance.

2.02.07 PERMITS

It is the obligation of the developer or contractor to obtain whatever permits may be legally required prior to the start of construction.

2.02.08 COORDINATION OF PLANS, SPECIFICATIONS, AND SPECIAL PROVISIONS

Standard Specifications, Plans, and Special Provisions are essential parts of the work. They are intended to be cooperative, descriptive, and provide for complete work. Requirements occurring in one shall be considered as occurring in all. Plans shall govern over Standard Specifications, and Special Provisions shall govern over both Standard Specifications and Plans.

2.02.09 LINE AND GRADES

1. Construction shall be conducted with the aid of alignment and grade stakes.
2. Finished grade for all water appurtenances shall be established prior installation.
3. Grade shall be established by an Engineer or Surveyor licensed in the State of Oregon.

2.02.10 SAFETY

Safety is the sole responsibility of the contractor. It is the contractor's responsibility to conform to all OSHA or other safety regulations. The MWC inspector is not responsible for patrolling safety issues.

2.03 COMPLETION

2.03.01 COMPLETION

1. Upon completion of the project, the contractor will notify the MWC 48 hours in advance of a desired final inspection.
2. MWC will in turn furnish a ***Dedication and Declaration of Acceptance of Water System Facilities*** form to be executed by the owner and MWC. The owner's Dedication provides for a one (1) year guarantee from the date of acceptance in which the owner agrees to indemnify and save harmless the MWC from any and all defects appearing or developing in the workmanship or material performed or furnished in the construction of the described water system facility.
3. The owner/contractor is required to supply a statement of actual cost of the project on the "Dedication and Declaration" form.
4. All outstanding fees must be paid to MWC before MWC will approve recording of the final map.

SECTION III

GUIDELINES & DESIGN CRITERIA

3.00 GENERAL

3.00.00 DESCRIPTION: General requirements for water facilities.

3.00.01 STATE OF OREGON REQUIREMENTS

In general, the State of Oregon's rules govern the quality of water and not the manner in which it is distributed. However, the rules do contain a limited number of standards with storage and piping criteria:

- Distribution piping shall be designed and installed so that the pressure measured at the property line of any user shall not be reduced below 20 psi (OAR 333-061-00580(9) (e)).
- Wherever possible, dead ends shall be minimized by looping. Where dead ends are installed, blow offs of adequate size shall be provided for flushing (OAR 333-061-0050(9) (h)).
- Wherever possible, distribution pipelines shall be located on public property. Where pipelines are required to pass through private property, easements shall be obtained from the property owner and shall be recorded with the county clerk (OAR 333-061-0050 (9) (a)).

3.00.02 EXISTING WATER MAINS AND WATER FACILITIES

Existing water mains and water facilities that are in non-conformation with the current MWC standards shall be brought into compliance with current MWC standards upon new developments and/or upgrades.

3.00.03 PROPOSED DESIGN OF WATER MAINS

Design of future (proposed) water mains and water facilities shall not create non-compliant conditions and/or maintenance hardships. All water main and water facilities shall be designed to current MWC standards.

3.01 WATER MAINS

3.01.00 DESCRIPTION: Requirements of water mains for water distribution systems.

3.01.01 TYPE OF PIPE

Pipe used for distribution mains shall be new Ductile Iron (DI) Pipe. All Ductile Iron Pipe with diameters of 4-inch (4") through 12-inch (12") shall have a wall thickness of Class 52. Pipe with diameters of 14-inch (14") through thirty-six-inch (36") shall have a wall thickness of Class 50. All pipe classes and styles shall be represented on Engineered plans.

Pipe used for transmission mains shall be new Class 50 Ductile Iron (DI) Pipe or Steel pipe. Either pipe material can be used depending on an engineering analysis. Transmission mains are those pipes with diameters forty-two inches (42") or larger. All Ductile Iron Pipe shall be encased with Polyethylene Encasement (Polywrap) in accordance with Medford Water Standard Specifications, no exceptions.

3.01.02 SIZE OF PIPE

The minimum water main size for residential development shall be eight-inch (8") in diameter unless otherwise approved by MWC. The minimum water main size for multi-family, commercial and industrial development shall be twelve-inch (12") in diameter unless otherwise approved by MWC. The minimum size for a water main with fire hydrants and water service and/or fire services on that water main shall be eight-inch (8") in diameter. The minimum water main size for fire service with water service and/or fire hydrants shall be at least one size bigger than the fire service water main, but shall be a minimum of eight-inch (8") if a fire hydrant is required. *Departures from the minimum requirements will be considered only in special circumstances.*

Water mains in cul-de-sacs that will not be extended in the future may be four-inch (4") in diameter if that size water main meets the development's build-out water demand requirements. No fire hydrants are allowed on four-inch (4") water mains.

If the existing water main is different than the minimums listed previously and the installation of the water main would complete a loop, then the size of the existing water main shall be used providing that the previously stated minimums are not violated.

Existing water mains that are under sized (i.e., 4" water in residential and 8" in commercial/industrial areas) shall be abandoned and new water mains installed per current MWC standards.

3.01.03 LOCATION OF PIPE

All water mains shall be located within the public right-of-way. If a dedicated right-of-way is not available, the water main may be located elsewhere upon MWC approval and upon the granting of an easement to MWC. Water mains shall not be installed in alleys and the installation of mains within easements across privately owned property is to be done only when absolutely necessary, such as the avoidance of dead-end conditions.

The standard location for water mains shall be within public streets and roads and shall be ten feet (10') from the centerline of such streets on either the south or west side of street centerlines. This standard may be changed depending on site specific circumstances and the approval by MWC. When traffic calming curbs are required the distance from centerline of the street may be reduced to eight feet (8'). Water mains shall be located a minimum of four feet (4') from the curb face in the travel way. Bends shall be at least four feet (4') from curbs along corners and the apex of curves.

Water mains located on private property (i.e., shopping centers, apartments, etc.) shall be located in the travel ways. Water mains shall not be located in backyards, side yards, between lots, median strips, planter areas, parking stalls, under curbs, gutters, sidewalk, buildings, covered areas, retaining walls, fences, etc. unless prior approval is obtained from MWC. Trees, landscape features, play yards, signs and any other above ground appurtenance shall not be placed over a water main. Water mains shall not be located in any place that would cause a future hardship of maintenance for MWC.

If the new main is being installed in a street that will be extended in the future, the main shall end three feet (3') beyond the end of the street. Water mains shall be designed to be compatible with anticipated future improvements. Water mains shall be looped whenever practical to avoid dead-end water mains.

Mains installed in a cul-de-sac shall run the full street length ending in the appropriate location for a fire hydrant installation. Small mains (4" diameter) shall end at the radius point of the cul-de-sac or an appropriate location to provide water services to the lots along with a blow off.

Multiple water mains running parallel in the same street right-of-way for the convenience of development are not allowed. Exceptions to these requirements may be made in order to avoid conflicts with other existing underground facilities or street facilities, to permit sanitary sewers to be installed on the low sides of streets and projects that lie in different pressure zones. Extension of existing mains shall be installed in the same relative location on a particular street with the distance from the centerline of the street being varied as little as possible.

When a proposed project alters the alignment of the roadway/travel way which results in the existing water main being in a less desirable position for maintenance and not per MWC current Standards, then the existing water main shall be abandoned in place and a new water main installed in the correct position per MWC current Standards.

Water mains shall cross storm drain pipes, sanitary sewer pipe and all other utilities as close to 90 degrees (90°) as possible. Skewed crossing shall not be allowed for proposed design and shall be held to a minimum for existing conditions.

3.01.04 OVERSIZING OF PIPE

MWC may require the Developer to oversize some, or all, of the proposed water main. MWC will reimburse the Developer for the cost of the difference in size of the pipe for pipe materials only. Prior to construction the Developer shall submit invoices from a minimum of three (3) pipe suppliers to MWC for review and approval. The invoices shall list the two different sizes of the pipes and fittings for a direct comparison. Once MWC and Developer have agreed upon the reimbursement amount, the developer may order the pipe.

3.01.05 FULL PROPERTY FRONTAGE EXTENSION OF PIPE

Water mains are required to be installed along the entire length of the property line frontage of the property to be developed whenever future line extension is possible. The property line frontage is that portion of the property along the public right-of-way. If a property to be developed has more than one property line frontage (i.e., corner lot) then water mains shall be installed along both frontages unless approved otherwise by MWC. All properties shall be required to extend water mains through the project site to facilitate future connection and extension of the water main to adjacent properties.

3.01.06 DEPTH OF COVER

All water mains and fire hydrant laterals require a minimum of thirty-six inches (36") cover unless otherwise approved by MWC. Normal depth of cover can vary from a minimum of thirty-six inches to forty-two inches (36"-42") of cover. Depth of cover exceeding 42 inches (42") must be justified with design of the water main.

The ideal cover, finished surface to top of the water line pipe barrel, over new water lines shall be as per current MWC standards of 36 inches (36"). However, minimal cover of twenty-four inches (24") will be allowed on ductile iron pipe and thirty inches (30") for cast iron pipe. This minimal cover shall only be allowed under MWC pre-approved situations and only for a limited distance (lengths of less than 50' feet). The depth of trenches shall be as shown on the Plans or as specified in the Detail Specifications. The grade line shown on the Plan and Profile shall be the pipe invert.

If the bottom of any extensive excavated sub-grade is within 18 inches (18") of the top of an existing water line pipe barrel, the water line shall be replaced per MWC current Standards

If the bottom of any extensive excavated sub-grade is between 18 and 30 inches (18"-30") of the top of an existing water line pipe barrel, the water line shall be protected during construction with original intact mounded material until such time the sub-grade area over the water line can be carefully removed, replaced and compacted.

To facilitate pre-design of potential conflicts, the MWC will, at their expense and timing, pot hole the location of the existing water lines upon request. The developer will be responsible for payment for the required backfill and re-surfacing of these pot holes per Jurisdictional Agency requirements.

When a water main is installed under a stream or other watercourse, a minimum cover of 30 inches (30") shall be provided over the carrier casing. The water main shall be installed in a carrier casing. Where the water course is more than 10-feet (10') wide, the pipe shall be of special construction with flexible watertight joints, valves shall be provided on both sides of the crossing so that the section can be isolated for testing or repair, and test cocks shall be provided at the valves.

3.01.07 CONNECTIONS TO EXISTING PIPES

1. Wet taps on mains:

Size on size (i.e., 8" tap on existing 8" pipe) wet taps are allowed on cast iron pipe, ductile iron pipe and welded steel pipe. Wet taps on concrete cylinder pipe must be one size smaller than the pipe being tapped. Wet tap connections to existing facilities shall be made only by MWC forces.

a. Contractor supplied materials:

The contractor shall provide, at their sole cost and expense, all materials necessary to perform the wet tap. The contractor shall

provide permits, traffic control, saw cutting of asphalt paving, removal of asphalt paving, excavation, shoring, dewatering, tapping sleeve, tapping valve, pipe zone material, backfill, trench plates, resurfacing, stripping, and any other items incidental to the wet tap. MWC shall tap or drill out the water main.

b. Existing stub pipes:

Pipes stubs that were installed with a previous project can be used for extension of the water main. The existing pipe stub must lie in the correct horizontal and vertical alignments to extend the water main. If the pipe stub is not in the correct alignment then the pipe stub shall be abandoned at the existing water main. A new tap shall be made on the existing water main and a new water main shall be installed to facilitate the project. Existing pipe stubs that are not used shall be abandoned with the proposed project regardless of when the pipe stub was installed. Existing pipe stubs shall be abandoned if the pipe stub is not the same size as the proposed water main extension. A new tap of the correct size shall be made on the existing water main to facilitate the proposed project. Existing pipe stubs of unknown origin shall not be used.

3.01.08 LOOPING OF PIPES

The distribution system lateral water mains shall be looped wherever possible. The installation of permanent dead-end mains and dependence of relatively large areas on a single water main is to be avoided. Looping shall be defined as a minimum distance of 500 feet between water main connection points.

A lateral water main is defined as a main not exceeding eight inches (8") in diameter which is installed to provide water service and fire protection for a local area.

The normal size of looped lateral water mains for single-family residential areas is eight-inch (8").

Unlooped lateral mains may not:

1. Exceed 1,500 feet (1,500') in length;
2. Be less than eight-inch (8") in size;
3. Be allowed without reasonable assurance of looping within two (2) years from date of installation. Meters, Fire Hydrants or Blow Offs shall be required to be placed at the end of the unlooped main.

The normal size of lateral mains for commercial, industrial, and multiple-family areas shall be twelve-inch (12") except that in the sole discretion of MWC, 8-inch (8") lateral mains may be allowed if flows meet domestic service and fire protection needs of an area.

SEPARATION BETWEEN PIPES

Separation of water mains, including service lines, and sanitary sewers shall be in accordance with current Oregon State Health Division Rules and/or as modified in Section IV, Item II, C-8 of these Standards EXCEPT in all cases running parallel with each other, there shall be a 10-foot separation (center line to center line).

The minimum horizontal spacing between water mains and storm sewers, gas lines, electrical conduits, telephone conduits and other underground utilities, excepting sanitary sewers shall be:

Separation Distance from Water Mains and Facilities to Other Utilities:

1. Minimum five-foot (5') horizontal separation centerline of pipe to centerline of pipe. For pipe larger than 18-inch (18") in diameter the horizontal separation shall be increased to meet Condition 2.
2. Minimum three-foot (3') horizontal between trench walls.
3. MWC requires 10-foot (10') parallel separation between water mains and sanitary sewer mains (centerline of pipe to centerline of pipe).
4. Minimum five-foot (5') horizontal distance between water facilities (water mains, fire hydrants, air release valves, water meters, etc.) and other utilities' facilities (transformers, enclosures, risers, boxes, manholes, curb inlets, catch basins, light/signal poles, structures, footing, overhangs, etc.).
5. Minimum five-foot (5') horizontal clearance between a fire hydrant and any other above ground obstruction to allow access to the hydrant.
6. Minimum vertical separation of six inches (6") outside of water main to outside of utility.

Water line/Sewer line Separation:

Reference OAR 333-061-0050 Ch. 10: All references to sewers in this section shall mean sanitary sewers.

1. In situations involving a water line parallel to a gravity sewer main or sewer lateral, the separation between the two shall be as indicated in Figure 1. MWC requires 10 feet (10') parallel separation between water mains and sanitary sewer mains.
2. In situations where a water line and a gravity sewer main or sewer laterals cross, the separation between the two shall be as follows:
 - a. Wherever possible, the bottom of the water line shall be 1.5 feet (1.5') or more above the top of the sewer line and one full length of water pipe shall be centered at the crossing.
 - b. Where the water line crosses over the sewer line but with a clearance of less than 1.5 feet (1.5'), the sewer line shall be exposed to the sewer line joints on both sides of the crossing to permit examination of the sewer pipe. The minimum vertical separation between water mains and sanitary mains shall be 8 inches (8"). All crossing between 1.5 feet (1.5') and 8 inches (8") require special material for sanitary sewer mains per DEQ Standards.

3. Where the water line crosses under the sewer line, the sewer line shall be exposed and examined. If conditions are favorable and there is no evidence of leakage from the sewer line, the sewer line may be left in place but must be supported with a steel or reinforced concrete beam or other means of preventing settlement when it spans the water line trench, and special precautions must be taken to assure that the backfill material over the water line in the vicinity of the crossing is thoroughly compacted in order to prevent settlement which could result in the leakage of sewage. One full length of water main pipe shall be centered at the crossing. The minimum vertical separation between water mains and sanitary mains shall be eight inches (8").

Figure 1: Water Line-Sewer Line Separation

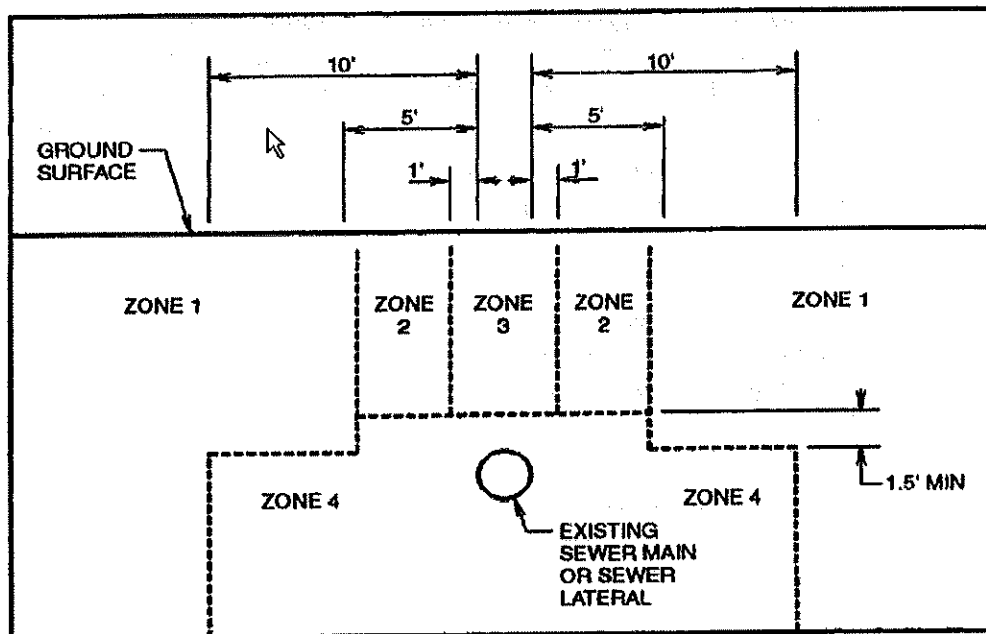

- Zone 1: Only crossing restrictions apply
- Zone 2: Case-by-case determination
- Zone 3: Parallel waterline prohibited
- Zone 4: Parallel waterline prohibited

3.01.10 PLUGGING & CAPPING OF PIPES

All water mains ends shall be plugged. Plugs and caps shall be per MWC Standards.

3.01.11 THRUST & ANCHORAGE BLOCKS

Concrete thrust blocks are required at all tees, bends and fittings used to change the pipe direction, and shall be placed in accordance with MWC Standard Details. If undisturbed material is not present (such as in fill sections) then mechanical restrained joints shall be required.

3.01.12 MECHANICAL RESTRAINED JOINTS

Mechanical restrained joints may be used in lieu of thrust blocks upon MWC approval, or as required by the MWC. The length of restraint joints should be clearly identified on drawings in the profile view.

All valves, bends, tees, reducers, plugs and fittings are required to be fully restrained.

All vertical changes in water main alignment using fittings and/or pipe joint deflection shall be restrained.

The minimum length for restraint is 18' (1-18' pipe length) plus fittings. Restrained joint lengths for mains shall be calculated by the Design Engineer using a factor of safety of 2.0, depth of cover, type of pipe bedding and backfill material, with a test pressure based of 150 psi.

All end runs of water main shall be restrained for future extension and/or testing purposes. The minimum end run restrain distance for 4", 6" and 8" diameter pipe shall be 54' (3-18' pipe lengths). The minimum end run restrain distance for 12", 14" and 16" diameter pipe shall be 90' (5- 18' pipe lengths).

Restrain calculations shall be based on either EBAA Iron Restrain Pipe Program or DIPRA program.

3.01.13 DEFLECTION OF PIPE

The maximum allowable water main joint deflection for ductile iron pipe and lengths is listed in the following tables. If these offsets conflict with the pipe manufacturer's recommendation, the more stringent requirement shall apply. Requirements in excess of these deflections identified shall require installation of fittings.

The maximum allowable joint deflection for push-on type joint and mechanical-joint pipe shall be as follows:

-- CONTINUED ON THE NEXT PAGE --

TABLE I					
MAXIMUM DEFLECTION OF MECHANICAL JOINT PIPE					
Safe Deflection for 150 Pounds Pressure					
Size of Pipe in Inches	Maximum Joint Deflection in Degrees	Deflection in Inches with Pipe Length of 18'	Deflection in Inches with Pipe Length of 20'	Approx. Radius	
				18 Feet	20 Feet
4	8	31	35	125	140
6	7	27	30	145	160
8	5	20	22	195	220
10	5	20	22	195	220
12	5	20	22	195	220
14	3.5	13.5	15	285	320
16	3.5	13.5	15	285	320
18	3	11	12	340	380
20	3	11	12	340	380
24	2	9	10	450	500
*For pressures above 150 pounds, reduce the tabulated deflection by 10% for each 150 pounds added pressures					
Tables I and II are based on DIRPA data					

TABLE II					
MAXIMUM PERMISSIBLE DEFLECTION IN LAYING PUSH-ON JOINT PIPE					
Safe Deflection for 150 Pounds Pressure					
Size of Pipe in Inches	Maximum Joint Deflection in Degrees	Deflection in Inches with Pipe Length of 18'	Deflection in Inches with Pipe Length of 20'	Approx. Radius	
				18 Feet	20 Feet
4	5	19	21	205	230
6	5	19	21	205	230
8	5	19	21	205	230
10	5	19	21	205	230
12	5	19	21	205	230
14	3	11	12	340	380
16	3	11	12	340	380
18	3	11	12	340	380
20	3	11	12	340	380
24	3	11	12	340	380
30	3	11	12	340	380
36	3	11	12	340	380

1. General:

Joint deflections shall be no more than 80 percent (80%) of maximum allowable deflection per manufacturer's specifications. All bends (11¼°, 22½°, 45° or 90°) and pipe joint deflections (deflection in degrees) shall be noted on the plans.

2. Horizontal Deflection:

Minimize bends/fittings by utilizing deflections in joints whenever possible.

Use standard fittings (11¼°, 22½°, 45° or 90°) for changes to the water main alignment when required. A combination of deflecting the pipe joint and a standard fitting may be required.

When utilizing joint deflections for proposed water mains on a horizontal radius, the minimum radius shall be per Table I or Table II depending on the type of pipe. The horizontal radius shall never exceed the manufacturer's recommendations or MWC's Standards.

3. Vertical Deflection:

Minimize bends/fittings by utilizing deflections in joints whenever possible.

Use standard fittings ($11\frac{1}{4}^\circ$, $22\frac{1}{2}^\circ$, 45° or 90°) for changes to the water main alignment when required. A combination of deflecting the pipe joint and a standard fitting may be required.

Design to avoid high points whenever possible. Attempt to locate grade breaks near proposed fittings.

3.01.14 GRADE FOR PIPE

The minimum grade for a water main shall be 0.20 percent (0.002 feet/foot). Water mains shall be installed with positive grade when ever possible. High point in water mains shall be avoided when possible. When water main grades exceed 19 percent (0.19 feet/foot) the water main shall be fully restrained per these Standards and slope anchors shall be installed.

3.01.15 POLY PIGS

Poly pigs are required for all water mains and shall be noted on the plans.

3.01.16 PIPE PIERS

Concrete pipe piers (bridging supports) per MWC's Standards are required at all utility crossing when the utility is crossing over the water main and the utility is larger than 18-inch (18") in diameter. Depending on the size and type of utility, concrete pipe piers will be required to span the water facility.

3.01.17 CRANKSHAFTS IN WATER MAINS

Crankshafts in water mains shall be kept to a minimum. Crankshafts shall be fully restrained. Valves may be required on both sides of the crankshaft depending on the conditions. The bottom of the crankshaft shall extend five feet (5') beyond the crossing on both sides of the crossing. A casing pipe may be required depending on the conditions.

3.01.18 FLEX-TENDS

Flex-tends (flexible expansion joints) are required for all water mains at bridge abutments or other water main installation conditions that would warrant a flexible connection.

3.01.19 DRY LINE PIPE

Installation of dry line pipes are not allowed in the MWC water system. All water mains shall be installed, tested and put into service.

3.02 VALVES

3.02.00 DESCRIPTION

This section covers the requirements for valves.

3.02.01 TYPE OF VALVES

Valves shall be per MWC standards. Gate valves and butterfly valves shall be used.

3.02.02 SIZE OF VALVES

Gate valves shall be used for sizes two-inch (2") to eight-inch (8") and tapping valves to twelve-inch (12"). Butterfly valves shall be used for sizes twelve-inch (12") and above. The standard sizes of valves are 2", 4", 6", 8", 12", and 16", unless an existing water main is of a different size. Valve sizes shall be the same size as the main in which the valve is being installed.

3.02.03 LOCATION OF VALVES

Valves shall be located in the public right of way. Valves shall be located at the extension of the right of way line out of the intersection of the street. Valves shall not be located in the curb, gutter panels, driveway aprons, behind fences or any other area that restricts the maintenance and operation of the valve.

3.02.04 SPACING OF VALVES

Valves shall be located at all intersections. Tee intersections shall have a minimum of two (2) valves and four way intersections shall have a minimum of three (3) valves. The maximum spacing between valves shall be eight hundred feet (800') in industrial and commercial areas and twelve hundred feet (1,200') in residential areas.

3.02.05 VALVE CANS AND LIDS

All valves shall have valve cans and lids installed with the valves. The lids shall have the word 'Water' stamped in it.

3.02.06 SPECIAL CROSSINGS

Railroad crossings, creek crossing, freeway crossing, bridges, slope installation, any hazardous installation and any other installation as deemed by MWC shall have at a minimum of one (1) valve on each side of the installation. Valves shall be installed before and after flexible expansion joints (i.e., flex-tend fittings).

3.03 FIRE HYDRANTS

3.03.00 DESCRIPTION

This section covers the requirements for fire hydrants.

3.03.01 FIRE HYDRANTS

The requirement of fire hydrants for fire protection is dictated by the local governing Fire Department and The International Fire Code not by MWC. The project engineer shall coordinate with the appropriate departments/agencies prior to starting design. Fire Hydrants shall be served by an independent 6-inch water main with no other services originating from the fire hydrant water main.

3.03.02 TYPE OF FIRE HYDRANTS

Fire hydrants shall be per MWC Standards Specifications and Details.

3.03.03 SIZE OF FIRE HYDRANTS

Fire hydrants for fire protection shall be six inches (6").

3.03.04 LOCATION OF FIRE HYDRANTS

Fire hydrants shall be located in the public right of way. Fire hydrants shall be located at the beginning or ending of the curb return. Fire hydrants shall not be located in the curb returns, driveways, travel ways and any other area that restricts the use of the fire hydrant. Fire hydrants shall be installed at the terminus of all unlooped (i.e., dead-ends and cul-de-sacs) water mains unless a Blow-Off is installed. There shall be a five-foot (5') clear zone around the fire hydrant for maintenance and operation.

3.03.05 SPACING OF FIRE HYDRANTS

Fire hydrants shall be spaced per the local governing Fire Department and The International Fire Code.

3.03.06 PROTECTION OF FIRE HYDRANTS

All fire hydrants shall be protected by six-inch (6") vertical curb or bollards per MWC standards. Curbs shall be located five feet (5') from the fire hydrant. Bollards shall be located per MWC standard Details.

3.03.07 SEPARATION OF FACILITIES

There shall be a minimum of five feet (5') horizontal clearance between fire hydrants and all other utilities, except sanitary sewer which shall be a minimum of ten feet (10'). There shall be a minimum of six inches (6") vertical clearance between fire hydrants laterals and all other utilities, except sanitary sewer which shall be a minimum of eighteen inches (18").

3.03.08 FIRE HYDRANTS DEDICATED FOR FIRE DEPARTMENT CONNECTIONS (FDCs)

Fire hydrants dedicated for fire department connections (FDC) shall be located in the proximity of the fire service vault. Water mains that serve both a fire

service and a dedicated fire hydrant shall be a minimum of eight-inch (8") in diameter. No other water service shall be taken from this water main.

3.03.09 FIRE HYDRANTS MAXIMUM LENGTH

Fire hydrant lateral lines shall not exceed 100 feet (100') in length.

3.03.10 EXISTING FIRE HYDRANTS

Existing fire hydrants shall not be removed and reinstalled. Existing fire hydrants that do not facilitate or are in conflict with proposed improvements shall be abandoned and a new fire hydrant installed in the appropriate location. Existing fire hydrants that need to be adjusted to grade shall be evaluated on case by case bases. If the existing fire hydrant has been in service for 15 years or more, then the fire hydrant shall not be adjusted to grade, but removed and a new fire hydrant shall be installed.

3.04 METERS AND SERVICE LINES

3.04.00 DESCRIPTION

This section covers the requirements for water meters and water service lines.

3.04.01 TYPE OF METERS AND SERVICE LINES

Water meters and service lines shall be per MWC standards. Residential water meters shall be sealed register (SR) positive displacement water meters. Commercial and industrial water meters shall be either turbo (series W) or combination (SRH) water meters. Service lines shall be copper, except for three-inch (3") and larger water services which shall be Class 52 ductile iron pipe.

3.04.02 SIZE OF METERS AND SERVICE LINES

The standard sizes for water meters shall be $\frac{5}{8}$ " by $\frac{3}{4}$ ", $\frac{3}{4}$ " by $\frac{3}{4}$ " (residential fire service/domestic water meter), 1", 1½", 2", 3", 4", 6", 8" and 10". No other sizes of water meters are allowed. The standard sizes for residential water meters are $\frac{5}{8}$ " by $\frac{3}{4}$ " and 1". The standard sizes for commercial and industrial water meter are $\frac{5}{8}$ " by $\frac{3}{4}$ ", 1", 1½", 2", 3", 4", 6", 8" and 10". The standard sizes for irrigation water meter are $\frac{5}{8}$ " by $\frac{3}{4}$ ", 1", 1½", 2" and 3". One inch (1") service lines shall be used with $\frac{5}{8}$ " by $\frac{3}{4}$ ", $\frac{3}{4}$ " by $\frac{3}{4}$ " and 1" water meters. Service lines shall match water meter sizes for 1½", 2", 3", 4", 6", 8" and 10", except for 3" water meters which shall have a 4" service line.

The $\frac{3}{4}$ " by $\frac{3}{4}$ " water meter will only be allowed for dual use as residential fire service/domestic water service.

Large water meters (i.e., 2" water meters and bigger) shall be installed with bypass water main to allow maintenance and testing of the water meter.

Each water meter shall be served independently via a service line from the water main. Multiple water meters from a single service line is not allowed.

3.04.03 LOCATION OF METERS AND SERVICE LINES

Water meters and service lines shall be located in the public right of way. Easements are required for water meter and service lines that are located on private property. Water meters and service lines shall be located at 90 degrees from the water main. Water meters and service lines located at the ends of cul-de-sacs shall be radial from the water main. Water meters shall be located in the back of sidewalk when the sidewalk is curb adjacent. Water meters shall be located in the parkway between the curb and the sidewalk when a parkway strip exists. Water meters shall be located as close as practical to the water main, long service lines are not allowed. Water meters shall not be located in the curb, gutter panels, driveway aprons, rock driveways, behind fences, bridges, railroad crossings, slopes, freeways, creeks, wetlands and any other area that restricts the maintenance and operation of the water meter.

Lot with double frontages shall have the water meter located on the street that the lot is addressed from. Corner lots have the option of having the water meter located on either frontage, but the street which the corner lot is addressed from is preferred. Cross-lot water services are not allowed.

In general water meters shall be located in front of the lot that the water meter serves. Refer to "Metering for Developments" for further guidelines.

3.04.04 PROTECTION OF METERS

All water meters shall be protected by six-inch (6") vertical curb or bollards per MWC standards drawings.

3.04.05 SEPARATION OF FACILITIES

There shall be a minimum of five feet (5') horizontal clearance between water meters and all other utilities, except sanitary sewer which shall be a minimum of ten feet (10'). There shall be a minimum of six inches (6") vertical clearance between water meters and all other utilities, except sanitary sewer which shall be a minimum of eighteen inches (18").

3.04.06 METERING FOR DEVELOPMENTS

1. Standard Residential Subdivision

One water meter per lot is required. Adjacent lot water meters (two meters) are to be grouped at a common property line when possible. Single water meters are to be placed in the middle of the lot. Multiple water meters shall be grouped at the driveway access at a minimum access easement (MAE) if applicable.

2. Additional Dwelling Unit (ADUs)

ADUs are allowed to be metered either separately (two meters) or jointly (one meter) depending on the fixture unit count and the UPC. If two water meters are required the water meters shall be grouped.

3. Duplexes

Duplexes are allowed to be metered either separately (two meters) or jointly (one meter) depending on the fixture unit count and the UPC. If two water

meters are required the water meters shall be grouped. The duplex unit must be constructed with a double common wall separating the two units with no utility penetrations.

4. Apartments

Apartment shall have one water meter per building. Multiple water meters per single building are not allowed due to the construction standards and cross connection control. A master water meter to serve multiple buildings may be allowed only if the property is retained under single ownership.

5. Condominiums

Condominiums shall have one water meter per building. Multiple water meters per single building are not allowed due to the construction standards and cross connection control. A master water meter to serve multiple buildings may be allowed only if the property is retained under a Homeowners Association with the homeowners association listed as the responsible party for payment of the water bill.

6. Townhouses

Townhouses shall have one water meter per building or one meter per townhouse. Multiple water meters per single building are allowed with construction of a double common wall separating the townhouses units with no utility penetrations. A master water meter to serve a building may be allowed only if the property is retained under a Homeowners Association with the homeowners association listed as the responsible party for payment of the water bill.

7. Commercial Multi-Tenant and EA OVERLAY/EFU

Commercial Multi-Tenant and EA overlay/EFU shall have one water meter per building. Multiple water meters per single building are not allowed due to the construction standards and cross connection control. A master water meter to serve multiple buildings may be allowed only if the property is retained under a Homeowners Association/ single ownership with the Homeowners Association/ single owner listed as the responsible party for payment of the water bill.

8. Commercial Single Tenant and EA OVERLAY/EFU

Commercial Single Tenant and EA Overlay/EFU buildings shall have one water meter per building.

9. Industrial Multi-Tenant

Industrial Multi-Tenant shall have one water meter per building. Multiple water meters per single building are not allowed due to the construction standards and cross connection control. A master water meter to serve multiple buildings may be allowed only if the property is retained under a Homeowners Association/ single ownership with the Homeowners Association/ single owner listed as the responsible party for payment of the water bill.

10. Industrial Single Tenant

Industrial Single Tenant buildings shall have one water meter per building.

11. Planned Unit Developments (PUDs)

Planned Unit Developments may have a combination of the metering schemes listed in 'a' through 'j' providing the metering scheme being proposed to MWC does not violate any backflow concerns, does not mix uses (i.e., residential and commercial), does not split building (i.e., different halves of the building being meter by different meters), etc. A master water meter to serve a PUD may be allowed only if the property is retained under a Homeowners Association with the Homeowners Association listed as the responsible party for payment of the water bill. A master water meter to serve multiple buildings may be allowed only if the property is retained under a Homeowners Association with the Homeowners Association listed as the responsible party for payment of the water bill.

All meter schemes for PUDs shall be approved by MWC prior to design of the water system.

12. Landscape and Irrigation

Landscape and irrigation meters are allowed for multi-family, commercial, industrial, open space, common space and PUD developments. Landscape and irrigation meters for single family residential are generally not allowed unless there is a compelling reason for a second water meter. If a second water meter is allowed for a residential lot, then backflow devices shall be installed on both water meters. Landscape and irrigation meters shall be kept to a minimum. The use of multiple landscape and irrigation meters to reduce zones within a landscape area shall not be allowed.

13. Existing Water Meter

If a proposed development has existing water meters to that development, then the existing water meters can be used. The existing water meters must meet all of the previous requires of these standards. If the water meters do not meet these standards then the water meters will be abandoned at the water main and new water meters will be required. If multiple water meter exist and all of the water meters are not used for the development, then the unused water meters shall be abandoned.

14. No Water Meter Required

Water meters are not required for commercial, industrial and reserved acreage lot that are only proposing to install water mains and not services. A note pertaining to water services must be shown on the final map per the mapping requirements of these standards (see 03.10.09).

3.04.07 REMOTE METERS

Remote meters are not allowed unless approved by MWC. Remote meter shall be kept to the shortest length of service line possible.

3.04.08 BACKFLOW

Backflow devices are required on all water meters serving multi-family, commercial, industrial, open space, common space and PUD (depending on metering scheme) developments. Backflow devices are required on all lots that

have active/inactive wells. Backflow devices shall be located in-line and adjacent to the water meter.

3.05 AIR RELEASE VALVE

3.05.00 DESCRIPTION

This section covers the requirements for air release valves.

3.05.01 TYPE OF AIR RELEASE VALVE

Air release valves shall be per MWC standards.

3.05.02 SIZE OF AIR RELEASE VALVE

Air release valves for water mains shall be one-inch (1"). Larger air release valves shall be approved by MWC.

3.05.03 LOCATION OF AIR RELEASE VALVE

Air release valves are required at all high points in water mains. Air release valves shall be located in the public right of way. Air release valves shall be the last water appurtenance on a dead end water main that ends with positive grade (i.e., uphill pipe). Air release valves shall not be located behind fences or walls.

3.05.04 PROTECTION OF AIR RELEASE VALVES

All air release valves shall be protected by six-inch (6") vertical curb or bollards per MWC standards.

3.05.05 SEPARATION OF FACILITIES

There shall be a minimum of five feet (5') horizontal clearance between air release valves and all other utilities, except sanitary sewer which shall be a minimum of ten feet (10'). There shall be a minimum of six inches (6") vertical clearance between air release valves and all other utilities, except sanitary sewer which shall be a minimum of eighteen inches (18").

3.05.06 INSULATION OF AIR RELEASE VALVE

Air release valves shall be wrapped with insulation materials when air release valve are subjected to freezing conditions. Air valves located on bridges and above ground application are two conditions requiring freeze protection.

3.06 BLOW OFFS

3.06.00 DESCRIPTION

This section covers the requirements for blow offs.

3.06.01 TYPE OF BLOW OFFS

Blows offs shall be per MWC standards.

3.06.02 SIZE OF BLOW OFFS

Blow offs for dead end water mains shall be two inches (2"). Blow offs for low points in water mains shall be one size smaller than the water main the blow off is serving (i.e., 6" blow off for an 8" water main)

3.06.03 LOCATION OF BLOW OFFS

Blow offs are required at low points in water mains and at the ends of water mains (i.e., dead end water mains and cul-de-sacs). Fire hydrants may be substituted for blow offs. Blow offs shall be located in the public right of way when possible. Blows offs shall be located in the proximity of drainage facilities.

3.03.04 PROTECTION OF BLOW OFFS

All blow offs shall be protected by six-inch (6") vertical curb or bollards per MWC standards.

3.03.05 SEPARATION OF FACILITIES

There shall be a minimum of five feet (5') horizontal clearance between blow offs and all other utilities, except sanitary sewer which shall be a minimum of ten feet (10'). There shall be a minimum of six inches (6") vertical clearance between blow off mains and all other utilities, except sanitary sewer which shall be a minimum of eighteen inches (18").

3.07 CASING

3.07.00 DESCRIPTION

This section covers the requirements for casing.

3.07.01 CASING REQUIRED

When ever a water facility is proposed to be located under railroad tracks, creeks, rivers, ponds, multiply culverts, bridges, bridge abutments, wetlands (environmentally sensitive areas), slopes, retaining walls, concrete walls, highway crossings and any other structures (natural or manmade) that inhibits maintenance of the water facility a carrier casing pipe shall be required. If an alternate route for the water facility is available then the alternate route shall be used.

When a water main is installed under a stream or other watercourse, a minimum cover of 30 inches (30") shall be provided over the carrier casing. The water main shall be installed in a carrier casing. Where the water course is more than 10 feet (10') wide, the pipe shall be of special construction with flexible watertight joints, valves shall be provided on both sides of the crossing so that the section can be isolated for testing or repair, and test cocks shall be provided at the valves.

Any utility crossing the BBS water transmission mains are required to be installed in casings.

3.07.02 TYPE OF CASING

Casing shall be installed per MWC standards. The project engineer shall coordinate with the appropriate departments/agencies concerning

departments/agencies requirements for casing. The most stringent standard for the casing shall apply for the project. The casing shall extend a minimum of ten feet (10') beyond the area requiring the casing at both ends.

3.07.03 WATER FACILITY IN CASING

The water facility located inside a casing shall be fully restrained. The area before and the area after the casing shall be of sufficient level length (minimum of 25 feet) to allow maintenance of the water facility and removal of the water facility from the casing.

3.08 SLOPES

3.08.00 DESCRIPTION

This section covers the requirements for water facilities in slopes.

3.08.01 WATER FACILITIES IN SLOPES

Water facilities are not allowed in slopes. If MWC approves water facilities to be installed parallel with a slope, the slope shall have a benched area (flat area with a width of ten-foot (10') minimum for the water facility. Water facilities shall be located in the center of the benched area. Water facilities shall not be located any closer than five feet from the top or bottom of a slope. If MWC approves water facilities to be installed perpendicular with a slope, the water facility shall be fully restrained from the bottom of the slope to the top of the slope. Slope anchors shall be installed on pipe for all slopes exceeding 19 percent (19%) (0.19 feet/foot) Depending on the nature of the slope, MWC may require the water facility to be installed in a casing.

3.09 ABANDONMENT OF WATER FACILITIES

3.09.00 DESCRIPTION

This section covers the requirements for abandonment of water facilities.

3.09.01 ABANDONMENTS

MWC requires that all existing water facilities that are not used for a proposed project be abandoned with that project at the direction of MWC. The abandonment may be for water mains, valves, fire hydrants, air valves, water meters and other water facilities. All water facilities to be abandoned shall be removed back to the water main servicing that water facility. The developer shall bear all cost associated with the abandonment.

3.09.02 WORK PERFORMED BY MWC

MWC forces shall perform all work associated with the abandonment of water facilities. Work for abandonment of water facilities shall not be preformed by private contractor unless approved by MWC and supervised by MWC.

3.10 EASEMENTS AND MAPS

3.10.00 DESCRIPTION

This section covers the requirements for easement across private property for water facilities.

3.10.01 LOCATION OF EASEMENT

Water facilities shall be located in the public right of way unless approved by MWC. If water facilities must be located on private property then the water facilities shall be located in travel ways. Easements shall be located on a single tax lot and not split tax lots. The easement shall be required to terminate at a property line for future extension. Other utility easements shall not encroach into the water easement unless approved by MWC. Over lapping of easements are not allowed unless approved by MWC. Water easements shall extend (cross perpendicular) through the Public Utility Easements (PUEs). Water easements shall not be located within a PUE.

3.10.02 SIZE OF EASEMENT

The water facilities easement shall be sufficiently wide to allow operation and maintenance of MWC facilities. The minimum width of an easement for a water main is ten feet (10'), with a minimum distance to the water main centerline of five feet (5'). Water mains shall be centered in the easement. If the water main cannot be centered in the easement, then the easement shall be increased to obtain the five feet (5') minimum to the centerline of the water main to the outer edge of the easement. Easements shall extend five feet (5') beyond fire hydrants and three feet (3') beyond water meter and air valves. Easements for backflow vaults shall extend to the demand side of the vault. The width of the easement shall be increased if more than one water facility is located in the easement. Example: if a water meter, fire hydrant and air release valve are located on the end of a water main, then the easement for the water meter, fire hydrant and air release valve shall be fifteen feet (15') wide. Easements located between buildings shall be a minimum of fifteen feet (15') in width. Easements located in residential side yards or rear yards shall be a minimum of twenty feet (20') in width. Easements for water transmission main (water mains 14" and greater) shall be a minimum of twenty feet (20') wide.

3.10.03 RESTRICTION OF EASEMENT

The water facilities easement shall be kept free and clear of structures, walls, fences, trees, signs, building overhangs and all other types of encroachments. The water facilities easement shall not be located in landscape areas except with prior approval by MWC. Under no circumstances will permission for the construction of a building or structure of any type within the easement be granted.

3.10.04 WRITING OF THE EASEMENT

All water facilities easements shall have a written meets and bounds legal description. The legal description can be included on the first page of the easement or attached and labeled as 'Exhibit A'.

3.10.05 ILLUSTRATING THE EASEMENT

The water facilities easement shall be clearly illustrated on the Plan view of the water plan. An illustration of the water facilities easement shall be provided with the legal description. The illustration of the water facilities easement shall be labeled 'Exhibit B' and attached to the legal description.

3.10.06 RECORDING THE EASEMENT

Once the water facilities easement has been approved by MWC and the easement has been executed and notarized, the water facilities easement shall be returned to MWC for recordation.

3.10.07 ACCESS ROAD FOR THE EASEMENT

Water facilities easements that lie outside of a paved travel way shall have a crushed rock access road constructed over the water facility. The access road shall be a minimum of ten feet (10') wide with a capability of carrying maintenance vehicles (i.e., loaded dump truck and backhoe) and provide any needed turn around.

3.10.08 MAPS

The recorded easements for water facilities and access roads shall be shown on subdivision and partition maps. Water facility easements shall not be created on subdivision and partition maps.

3.10.09 DOMESTIC WATER SERVICE NOT PROVIDED

If an existing water main is available to provide water service to a newly created parcel, but the owner/developer does not want to provide water service at the time of the recording of the map a note shall be shown on the map. The note shall state 'Pursuant to ORS 92.0090(c) no domestic water supply facility will be provided to Parcels/Lots 1, 2 and 3 at the time of recording this plat, even though a domestic water supply source exists in (Street Name). This section pertains primarily to commercial, industrial and reserves acreage.

3.10.10 CORRECTION TO RECORDED EASEMENT

If an easement has been recorded and there is an error in that easement's legal description and/or the illustration, then a revised easement shall be recorded. The revised easement shall contain the following statement, 'The purpose of this document is to replace and supersede Instrument No 200X-XXXXX of the Official Records of Jackson County, Oregon'. The revised easement shall be recorded by the Grantor and the original recorded document of the revised easement shall be returned to MWC.

3.10.11 EASEMENT FOR WATER DISTRICTS

Easements for water facilities in Water Districts shall be submitted to MWC for review and approval. The Grantee of the water easement shall be the Water District. MWC easement format shall be used for Water District easements.

3.11 FIRE SERVICES

3.11.00 DESCRIPTION

This section covers the requirements for fire service.

3.11.01 FIRE SERVICE

The requirement of a fire service is dictated by the Uniform Building Code and The International Fire Code not by MWC. The project engineer shall coordinate with the appropriate departments/agencies prior to starting design of a fire service. Fire Services shall be served by an independent water main with no other services originating from the Fire Service water main.

3.11.02 TYPE OF FIRE SERVICE

Fire services shall be double check detector assembly, double check valve assembly (must be preceded by a water meter) or reduced pressure principle assembly. Refer to MWC's *Standards for Fire Protection Systems and Regulations Governing Water Service*, Section 21.7, for additional requirements.

3.11.03 SIZE OF FIRE SERVICE

Fire services are classified as either large: three-inch (3") or larger, or small: two-inch (2") and smaller. The larger fire service shall be double check detector assembly, double check valve assembly (must be preceded by a water meter) or reduced pressure principle assembly. The smaller fire services require a water meter to precede the backflow device. The usual backflow device for a small fire service is a double check valve assembly. Refer to MWC's *Standards for Fire Protection Systems* for additional requirements.

3.11.04 LOCATION OF FIRE SERVICE

Fire Services shall be located on the private property that the fire service serves. Fire services shall not be located in the public right of way or in public utility easements. Fire services shall be located 90 degrees (90°) to the water main and as close as possible to the water main. Fire services shall not be located inside buildings unless approved MWC.

3.11.05 REQUIREMENTS OF FIRE SERVICES

Domestic water shall not be taken from a fire service. Fire services shall only service one (1) tax lot and be located on that tax lot. Fire service water mains shall only service the fire services and not fire hydrants and water meters. Easements are required for fire services. Private pumps systems for fire services are discouraged and are only allowed with approval from MWC.

3.11.06 ABANDONMENT OF FIRE SERVICES

Fire services can be abandoned if clearance from the Fire Department and the insurance agency are obtained and submitted to MWC for approval. The party requesting the abandonment shall bear all cost associated with the abandonment. Fire services shall be abandoned at the water main.

3.11.07 FIRE SERVICES TO MULTIPLE BUILDINGS

In general a single fire service serves a single building. However, a fire service may serve multiple buildings on a single lot as long as the lot and buildings are retained under a single ownership and the owner is the responsible party for payment of the monthly fire service. A fire service may serve multiple buildings for a PUD development. A master fire service to serve multiple buildings may be allowed only if the property is retained under a Homeowners Association with the homeowners association listed as the responsible party for payment of the monthly fire service fee.

3.12 COSTS AND SYSTEM DEVELOPMENT FEES

3.12.00 DESCRIPTION

This section covers the requirements for project fees and system development fees. All fees are reviewed annually and are subject to change. Fees increase or decrease in July or August of each year. Fees for a project are based on the current fee rates and not on the date of the fee letter or project inception. Fees are established and approved by the MWC Board. Copies of approved rates are available upon request. Prepayments of fees to circumvent rate increases are not allowed.

3.12.01 PROJECT FEES

MWC assesses project fees upon completion of plan review. The initial project fees are an estimate with a final project fee being determined at the final project completion. The initial project fees is an estimate for planning application review, writing the Conditions of approval, attending the Land Development meeting, review and approval of construction drawings, writing and issuing of the fee letter, review and recording of easements, writing and issuing of the work order, attending the preconstruction meeting, construction inspection, water main taps, flushing of water mains, pressure testing of water mains, chlorination and dechlorination of water mains, taking and testing of water samples, tie ins of water mains, GPS of water facilities, mapping of water facilities, finaling of the project and final map clearance. There are many other items that are project specific that are listed in the fee letter. All fees listed in the fee letter are due prior to the scheduling of the preconstruction meeting.

3.12.02 SYSTEM DEVELOPMENT FEES

MWC currently has system development fees for water meters and high level development. The system development fees for water meters are for the expansion of the Water Treatment Plant. The system development fees for the Eastside and the Southwest pressure zones are for high level development. The high level development is any development above an elevation of 1,500

feet. The high level development fee is for pump stations, reservoirs and water transmission mains that serve above an elevation of 1,500 feet.

3.12.03 METER FEES

Meter fees are based on whether a meter is a dry tap or a wet tap. Dry tap water services are for materials only and are installed by a MWC pre-qualified contractor during installation of the water main. Wet tap water services are installed on an existing water main by MWC staff. Meters larger than 1-inch (either dry tap or wet tap) are installed by MWC staff. Meter installation fees are based on meter size and surface type (paved or unpaved condition).

Existing water meters are presumed to have had all associated fees paid in full.

3.12.04 ABANDONMENT OF EXISTING METER FEE

Abandonment of existing water meters are performed by MWC staff at the rates approved by the Board of Water Commissioners.

3.12.05 STREET MORATORIUM FEES

Street moratorium fees are established by The City of Medford and are payable at the Public Works Department. The owner/developer is responsible for payment of all street cut moratorium fees prior to work starting on the project by their contractor or MWC forces. Proof of payment of fee to the Public Works Department must be submitted to MWC prior to MWC scheduling any construction.

3.12.06 TRANSFER OF SYSEM DEVELOPMENT FEES

The SDC fee on an existing water meter that will be abandoned can be credited towards a new/proposed meter, if the developer pays for abandonment of the existing meter to be removed. Transferring of SDC fees credits only applies to the project being done and can not be transferred to another project on a different site or future project. Crediting of SDC fee from one phase of a project to a future phase of that same project is allowed. If multiply water meters exist on a lot that is being developed and the water meters were installed prior to creation of SDC fees, then only the amount of SDC fee equal to the new SDC fees will be transferred. Surplus SDC fee for existing water meter (meters installed prior to creation of SDC fees) will not be refunded.

3.12.07 FEES FOR WATER METERS TO LOTS NOT CREATED

If a situation arises (street moratorium, unrecorded subdivision map, etc.) that warrants the installation of water meters to lots that have yet to be created, then all fees associated with those water meters shall be paid in full prior to installation of the water meters. An additional fee for the possible abandonment (if the subdivision should be denied, etc.) of those water meters and related street moratorium fees shall also be paid in full prior to installing the water meters. Once the subdivision is approved then the addition fees will be refunded to the payee upon the payee request.

3.12.08 FEES FOR NIGHTTIME/WEEKEND WORK

Installation of water facilities shall be done during normal working hours (8:00 a.m. to 5:00 p.m., Monday-Friday) If a situation arises that warrants the inspection and/or installation of water facilities to be installed after 5:00 p.m. or on weekends, fees for nighttime/weekend work (overtime rates for inspection and service crews) will be charged. Prior approval from MWC must be obtained before scheduling nighttime/weekend work. An estimate of additional fees for nighttime/weekend work will be calculated by MWC and must be paid to MWC prior to starting nighttime/weekend work.

3.12.09 EXISTING LOTS IN SDC FEE AREA

Existing lots (vacant lots without water meters/ houses on wells) that are located in areas where SDC fees are assessed will be charged full current SDC rates when applying for water meter service.

3.13 PRIVATE PUMP SYSTEM

3.13.00 DESCRIPTION

This section covers the requirements for private pump systems.

3.13.01 PRIVATE PUMP SYSTEM

MWC does not allow private pumps to pump water directly from MWC water mains. Private pumps systems are discouraged and only allowed with approval from MWC.

3.13.02 REQUIREMENTS FOR PRIVATE PUMP SYSTEM

Private pump systems shall receive water service via an air gap backflow. Water from a MWC meter shall flow from the back of the water meter to the holding tank via a private service line. The private service line shall discharge the water via an air gap into a holding tank. The holding tank shall have an overflow device set a minimum six inches (6") below the bottom of the air gap. The private pump shall pump the water from the holding tank. There shall be no direct connection between the private pump and MWC's water system.

3.14 PRESSURES ZONES

3.14.00 DESCRIPTION

This section covers the requirements for pressure zones for water mains.

3.14.01 LOCATION OF PRESSURE ZONES

MWC currently has nine (9) pressure zones. Each pressure zone is approximately 150 feet of elevation. The pressure at the top of the pressure zone is approximately 35 psi and at the bottom of the pressure zone is approximately 100 psi. MWC's objective is to deliver 35 psi at the water meter. The UPC requires pressure reducing valves on all water services in excess of 80 psi.

3.14.02 LIST OF PRESSURES ZONE

Reduced Pressure Zone: Elevation of 1251 feet to 1350 feet.

Gravity Zone (Zone 0): Elevation of 1350 feet to 1500 feet.

Eastside Zone 1A: Elevation of 1500 feet to 1650 feet.

Eastside Zone 2: Elevation of 1650 feet to 1800 feet.

Eastside Zone 3: Elevation of 1800 feet to 1950 feet.

Eastside Zone 4: Elevation of 1950 feet to 2100 feet.

Eastside Zone 5: Elevation of 2100 feet to 2250 feet.

Barneburg Pressure Zone 1B: Elevation of 1450 to 1600 feet.

Southwest Zone 1C: Elevation of 1484 feet to 1650 feet.

The Gravity Zone serves the Eastside Zones 1 to 5, the Barneburg Zone and the Reduced Pressure Zone. The Reduced Pressure Zone is also served by the Duff Water Treatment Plant during the summer months. The Southwest Zone is served by the Southwest Reservoir.

3.14.03 DESIGN CONSIDERATION OF PRESSURE ZONES

When a project splits two pressure zones, the project shall receive water service from higher pressure zone. Dual water mains in a street, one water main for a high pressure zone and one water main for a lower pressure shall be avoided. A single water main serving both pressure zones off of the higher pressure zone shall be installed. The Developer's engineer shall coordinate a pre-design meeting with MWC Engineering Division prior to starting design of plans.

3.15 TESTING AND DISINFECTION

3.15.00 DESCRIPTION

This section covers the requirements for pressure testing and disinfection of water mains.

3.15.01 PRESSURE TESTING OF WATER MAINS

All water facilities shall pass a pressure test (hydrostatic) per AWWA standards and MWC standards prior to being disinfected. The test pressure shall be 1½ times the normal static pressure, but not less than 150 pounds per square inch. Water facilities shall be backfilled prior to testing. Refer to Section IV, Part II, C-9 to C-9.6 of these standards for procedure.

3.15.02 DISINFECTION OF WATER MAINS

All water facilities shall be disinfected per AWWA standards and MWC standards. All water facilities shall be proven to be bacteriology safe prior to placing water facilities in service by MWC.

3.16 WATER DISTRICT

3.16.00 DESCRIPTION

This section covers the requirements for obtaining water service from a water district.

3.16.01 LOCATION OF WATER DISTRICT

Currently there are three water districts, Charlotte Ann Water District, Elk City Water District and Jacksonville Highway Water District. Charlotte Ann Water District lies along South Pacific Highway from Garfield Road to the City of Phoenix. Elk City Water District lies along South Pacific Highway from City of Central Point to Highway 238. Jacksonville Highway Water District lies along Jacksonville Highway/West Main Street from Lozier Lane to Pioneer Way. The boundaries of these water districts constantly change due to the ongoing annexation of properties into the City of Medford. Prior to starting design on a project within any of the water districts check with MWC to confirm status of project pertaining to location within water district.

3.16.02 APPROVAL OF PLANS BY WATER DISTRICT

Approval from the Water District must be obtained and submitted to MWC prior to starting construction of water facilities for a project. The Water Districts only meet once a month, so coordination with the Water District is prudent in order to obtain approval and fee amounts. All tap fees, Water District fees, System Development Fees, Installation fees and/or any other fees must be paid to the Water District prior to starting construction. Proof of payment to the Water District shall be submitted to MWC.

3.17 BIG BUTTE SPRINGS WATER TRANSMISSION MAINS

3.17.00 DESCRIPTION

This section covers the requirements for construction within Big Butte Spring (BBS) water transmission main easements. The Big Butte Spring (BBS) water transmission mains are the main source of water supply for the City of Medford and other areas served by MWC. All measures shall be taken to protect the BBS water transmission mains. No detrimental activities shall be allowed within the BBS easements.

3.17.01 LOCATION OF BBS WATER TRANSMISSION MAINS

BBS Water Transmission Mains #1 and #2 lie within 50-foot or 60-foot-wide easements. Restrictions covering the type of activities are listed in the recorded easements. The specific easement should be reviewed for restriction and exact location of the water mains. No encroachments are allowed within the easements without express written consent from the Board of Water Commissioners.

3.17.02 ACTIVITIES AROUND BBS WATER TRANSMISSION MAINS

MWC's inspector shall be on site at all times during any activities around the BBS water transmission mains.

SECTION IV

STANDARD SPECIFICATIONS FOR MATERIALS AND INSTALLATION

IV

STANDARD SPECIFICATIONS FOR MATERIALS AND INSTALLATION

TABLE OF CONTENTS

- I Standard Specifications for Trench Excavation, Backfill and Shoring**
- II A Standard Specifications for Ductile Iron Pipe, Ductile Iron Fittings, Valves and Fire Hydrants**
- II B Standard Specifications for Steel Pipe and Fittings, an Alternate Pipe for Transmission Mains 42-Inches and Larger**
- III Standard Specifications for Water Services**
- IV Standard Specifications for Polyethylene Encasement (Polywrap)**

I

**STANDARD SPECIFICATIONS
FOR
TRENCH EXCAVATION, BACKFILL AND SHORING**

INDEX

A. SCOPE

B. MATERIALS

- B-1. Gravel for Backfill
- B-2. Selected Backfill Material
- B-3. Gravel Surfacing Material
- B-4. Sand
- B-5. Sand Slurry (CLSM)

C. WORKMANSHIP

- C-1. Progress of Construction
- C-2. Trench Width
- C-3. Grade
 - C-3.1. Bedding
 - C-3.2. Pipe Zone
- C-4. Rock Excavation
 - C-4.1. Definition of Rock Excavation
 - C-4.2. Depth of Rock Excavation
 - C-4.3. Use of Explosives
 - C-4.4. Repair of Damage
- C-5. Shoring, Sheet piling and Bracing of Trenches
- C-6. Piling of Excavated Material
- C-7. Removal of Water
- C-8. Trench Backfill
 - C-8.1. Class "A" Backfill
 - C-8.2. Class "B" Backfill
 - C-8.3. Class "C" Backfill
 - C-8.4. Class "D" Backfill

C-8.5. Class "E" Backfill
C-8.6. Class "F" Backfill
C-8.7. Class "G" Backfill
C-8.8. Compaction

- C-9. Excess Excavated Material
- C-10. Roads, Street, and Driveway Crossings
- C-11. Permits and Easements
- C-12. Interfering Structures and Utilities
- C-13. Field Relocation
- C-14. Obstructions
- C-15. Excavation Across Cultivated Land
- C-16. Clearing the Right-of-Way
- C-17. Pavement Removal

**STANDARD SPECIFICATIONS
FOR
TRENCH EXCAVATION, BACKFILL AND SHORING**

- A. SCOPE:** This standard specification shall cover the materials and workmanship for trench excavation, backfill and shoring for the preparation of installation of water facilities.
- B. MATERIALS**
- B-1. Gravel for Backfill: Gravel for backfill shall be clean, creek run gravel with maximum size of four-inch or three-quarter-inch (4" or ¾") minus crushed rock, uniformly graded from coarse to fine. Four-inch and three-quarter-inch (4" and ¾") minus crushed rock shall conform to and be provided from a source list on the latest City of Medford Approved Aggregate Letter. See City of Medford website: www.ci.medford.or.us; click on City Department>Public Works, then open Approved Aggregate Letter on the left side of the screen.
- B-2. Selected Backfill Material: Selected backfill material may contain pieces of material of a size up to 4-inch (4") in diameter provided that such material shall have a sufficient gradation to permit reasonable compaction.
- B-3. Gravel Surfacing Material: Unless otherwise indicated in the Detail Specifications, gravel surfacing material for use with Class "A" or "E" Backfill shall be three-quarter-inch (¾") minus crushed rock uniformly graded from coarse to fine. Three-quarter-inch (¾") minus crushed rock shall conform to and be provided from a source list on the latest City of Medford Approved Aggregate Letter. See City of Medford website: www.ci.medford.or.us, click on City Department, Public Works, then open Approved Aggregate Letter on the left side of the screen.
- B-4. Sand: Shall be uniformly graded coarse sand with a maximum particle size of one-quarter-inch (1/4").
- B-5. Sand Slurry: One sack non-compressible mix consisting of sand, water, and a quantity of Portland Cement from 90 to 100 pounds per cubic yard of slurry mix. A slump of at least six inches (6"), but not more eight inches (8"), shall be used. Sand slurry backfill shall conform to the road authority agency.
- C. WORKMANSHIP**
- C-1. Progress of Construction: It is the intent of these Standard Specifications that the progress of the work shall be in a systematic manner so that as little inconvenience as possible will result to the public in the course of construction. It is necessary, therefore, that the contractor confine his operations to as small a length of work per crew as is feasible. Except by permission of the Engineering Division, at no time shall the trenching equipment be farther than 200 feet ahead of each pipe laying crew. Backfill of the trench shall be accomplished so that no section of approved pipe shall be left open longer than 48-hours except by permission of the Engineering Division. Complete backfill and clean-up shall

progress as each section of pipe has been inspected and approved. The contractor shall repair and re-grade all existing drainage ditches, natural drainage courses and all other drainage facilities including culverts damaged or removed during the construction.

The contractor shall give prompt consideration for reopening streets, roads and driveways to the public after the line has been installed past these points. No traffic-way shall be closed while work is suspended over weekends or holidays, and closures during work days shall be as brief as practicable. Where private accesses are to be closed, the property owner shall be notified by the contractor at least 24 hours in advance of the closure. Access for fire and emergency equipment for the protection of buildings, lives and property shall be maintained at all times.

- C-2. Trench width: Minimum width of unsheeted trenches in which pipe is laid shall be 18 inches (18") greater than the inside diameter of the pipe for 24-inch (24") and larger pipe and 12 inches (12") for less than 24-inch diameter pipe except in cases where excess width of excavation would cause damage to adjacent structures, or where the Plans limit the clear width at the top of the pipe to avoid pipe failure due to excessive external load. Trench width in blasted trenches shall be a minimum of 24 inches (24").
- C-3. Grade: The bottom of the trench shall be carried to the lines and grades shown on the Plans or as established by the engineer with proper allowance for pipe thickness and bedding. Any over-excavation shall be corrected with approved material thoroughly compacted.
 - C-3.1. Bedding: Three inches of material specified in B-3 hereof shall be placed in the bottom of the trench to provide a means of uniform pipe support. Bell holes shall be dug to properly support the full length of the pipe in the bedding.
 - C-3.2. Pipe Zone: Pipe zone shall be defined as the area of the trench from the top of the bedding to six inches (6") over the top of the pipe. Material specified in B-3 hereof shall be placed in the pipe zone of all trenches.
- C-4. Rock Excavation:
 - C-4.1. Definition of Rock Excavation: Unless otherwise defined in the Detail Specifications, the term "rock" shall be understood to mean solid sandstone, limestone, granite, basalt, or other solid rock of equal hardness in ledges, bedded deposits, or unstratified masses that, in the Engineering Division's opinion will require the use of systematic drilling and blasting for removal and, in fact, did require systematic drilling and blasting for removal except that when mutually agreed upon by the Engineering Division and the contractor or his representative prior to removal "rock" may be removed by the power-operated hand tools such as pneumatic pavement breakers. Boulders less than one-half cubic yard in volume will not be classified as rock. Cemented gravel (conglomerate), shale, clay, and other sedimentary materials will be classified as rock only when, in the Engineering Division's opinion, systematic drilling and

blasting is required for removal, and in fact, did require systematic drilling and blasting or power-operated hand tools for removal. Loam, sand, gravel, clay or other such material stratified between the layers of rock will not be classified as rock.

It shall be the contractor's responsibility, when directed by the Engineering Division, to remove all loam, sand, gravel, clay, or other such material above the rock and clean off and expose the rock surface in a satisfactory manner so that the Engineering Division may examine the surface and obtain any measurements he requires. Measurement will include only the actual volume of the rock to be removed.

Unless otherwise specified in the Detail Specifications, the quantity of rock shall be measured by the Engineering Division and the contractor or his representative prior to backfilling the trench and the amount of the rock determined, agreed upon, and made a matter of record by both parties.

- C-4.2. Where rock is encountered, it shall be excavated to a depth three inches greater than the required grade when water main pipe and fittings are to be installed. The trench shall then be backfilled with selected backfill material, thoroughly compacted, to establish the proper grade for the pipe.
- C-4.3. Use of Explosives: When the use of explosives is necessary for the prosecution of the work, the contractor shall use the utmost care so as not to endanger life or property, cause slides, or disturb materials outside the neat lines of the trenches or excavations.

The developer and contractor are advised to obtain a specialist's recommendation as to the clearance to be maintained from Medford Water Commission (MWC) facilities. The liability of damaged facilities, lost water and revenue from such rests with the developer and his contractor. Absolutely no blasting will be allowed within dedicated easements of MWC.

All explosives shall be stored in a safe, secure manner in compliance with local laws and ordinances, and all such storage places shall be marked clearly "Dangerous Explosives". No explosives shall be left in an unprotected manner along or adjacent to any highway, street, alley, or other area where such explosives could endanger persons or property. Storage of explosives shall be in accordance with the requirements of the State of Oregon Workmen's Compensation Board or similar appropriate body having the jurisdiction in such matters in the state in which the work is performed.

Only persons experienced in the handling of explosives shall be allowed to use them on the work. Where state or local laws require that explosives be handled only by licensed personnel, it shall be the contractor's responsibility to see that this requirement is met.

The contractor shall provide all necessary approved types of tools and devices required for loading and using explosives, blasting caps and accessories. The contractor shall conform his acts to and shall obey all Federal, State and local laws that may be imposed by any public authority or directions that may be given from time to time by the Engineering Division relative to the handling, placing and firing of explosives. No blasting shall be done adjacent to any portion of exposed work or structures unless proper precautions are taken to insure that the structures and materials surrounding and supporting the same will not be damaged by the blasting. When blasting rock in trenches, the contractor shall cover the area to be shot with blasting mats or other approved type of protective material that will prevent the scattering of rock fragments outside of the excavation. The contractor shall give ample warning to all persons within the vicinity prior to blasting and shall station men and provide signals of danger in suitable places to warn people and vehicles before firing any blasts. Unless otherwise approved by the Engineering Division, all blasts shall be fired with an electric blasting machine which shall not be connected in the circuit until just prior to the time for firing and shall be connected by the man who will operate the blasting machine. After a blast has been fired, the blaster shall make a minute inspection to determine if all charges have exploded before employees are allowed to return to the operation.

Misfires shall be corrected in accordance with the requirements of the applicable portions of the State or local Safety Code for blasting. The contractor shall be responsible for any and all damages to property or injury to persons resulting from blasting or accidental or premature explosions that may occur in connection with his use of explosives.

- C-4.4. Repair of Damage: In case injury from blasting occurs to any portion of the work or to the material surrounding or supporting the same, the contractor, at his own expense, shall remove such injured work, repair the work, and replace the material surrounding or supporting the same, or shall furnish such material and perform such work or repair or replacement as the Engineering Division shall order. Any damage whatever to any existing structures due to blasting shall be promptly, completely and satisfactorily repaired by the contractor at his own expense.
- C-5. Shoring, Sheeting and Bracing of Trenches: All shoring shall conform to the latest approved OSHA standards. Where sheeting and bracing are used, trench widths shall be increased accordingly. Trench sheeting shall remain in place until the pipe has been placed, tested for defects, and repaired if necessary, and the earth around the pipe compacted to a depth of four inches over the top of the pipe. All shoring, sheeting and bracing of trenches shall be per current OSHA Standards.
- C-6. Piling of Excavated Material: All excavated material shall be piled in a manner that will not endanger the work and that will avoid obstructing sidewalks and driveways. Hydrants under pressure, valve boxes, meter boxes, or other utility controls shall be left unobstructed and accessible until the work is completed.

Gutters shall be left clear or other satisfactory provisions made for street drainage, and natural water courses shall not be obstructed.

C-7. **Removal of Water:** The contractor shall provide and maintain ample means and devices with which to promptly remove and dispose of all water entering the trench excavation during the time that the trench is being prepared for the pipe laying, during the pipe laying, and for such additional time as may be required for the setting or hardening of joint materials, during the time that the backfill is being placed, and at such other times as may be specified in the Detail Specifications. The contractor shall dispose of the water in a suitable manner without damage to adjacent property.

C-8. **Trench Backfill:**

C-8.1. **Class "A" Backfill:** The entire depth of the trench shall be backfilled with material as specified in Item B-3 hereof (3/4" minus crushed rock). This material shall be placed in layers not exceeding 12 inches in loose depth and each layer thoroughly compacted with a vibratory compactor that compacts granular material by a combination of weight, vibration, and impact. A minimum of two passes over each layer at a speed not exceeding 60 linear feet (60LF) per minute shall be made with the vibratory compactor. It shall, however, remain the contractor's responsibility to determine the amount of compaction in excess of the minimum required to prevent subsequent settlement of the backfill. Any subsequent settlement of the finished surfacing during the one (1) year warranty period shall be the contractor's responsibility and shall be promptly repaired by the contractor at no cost to MWC. This item shall include the removal and disposal from the work site of all of the excavated material by the contractor at his expense.

C-8.2. The entire depth the trench shall be backfilled with material as specified in Item B-1 hereof (4" minus crushed rock).

This material shall be placed in the manner specified in Item C-8.6. hereof (wheel-rolled). This item shall include the removal and disposal of all of the excavated material by the contractor at his expense.

C-8.3. **Class "C" Backfill:** The trench shall be backfilled with materials as specified in Item B-4 hereof (sand) to a compacted depth of 6 inches (6") below the ground surface and the remaining six inches (6") of trench shall be filled with material conforming to Item B-3 hereof. The backfill shall be water settled by the "Flooding" or "Jetting" method.

Ample water shall be added by the flooding method to completely saturate the backfill. The jetting method utilizes a hose and long pipe nozzle. The nozzle shall be inserted at such spacing as necessary to completely saturate the backfill. Caution should be exercised to insure that excess water is not used. In the event of too much water, the contractor will be required to pump out all excess at the contractor's expense. Care shall be taken to prevent compaction of the top of the backfill by mechanical backfill equipment or street traffic prior to water

settling of the backfill. This item shall include the removal and disposal from the work site of all excess excavated material by the contractor at his expense.

- C-8.4. Class "D" Backfill: The trench shall be backfilled with excavated material in the manner specified in Item C-8.6. hereof. This material shall be water settled as specified in Item C-8.3. hereof. Excess material shall be windrowed directly over the trench.
- C-8.5. Class "E" Backfill: The trench shall be backfilled with excavated material and water settled in the manner specified in Item C-8.4. except that the top of the water settled excavated material which has been backfilled shall be left 6 inches below the ground surface and the remaining 6 inches of trench shall be filled with material conforming to Item B-3 hereof. The final backfilled surface shall be at the same level as the original surface. This item shall include the replacement of all gravel surfacing removed or disturbed by any of the construction operations whether within or outside the actual trench area. This item shall include the removal and disposal from the work site of all excess excavated material by the contractor at his expense.
- C-8.6. Class "F" Backfill: The excavated material may be pushed back into the trench by mechanical means except that no rocks larger than 4-inches in any dimension shall be backfilled. Where this method of backfill is allowed, the earth shall be pushed first onto the slope of the backfill previously placed and allowed to roll down into the trench. Under no circumstances shall sharp, heavy pieces of material be allowed to drop directly onto the pipe zone material. No organic material shall be allowed in the trench backfill. Excavated material to be wheel rolled compacted and excess material to be windrowed directly over the trench, except that rocks larger than 4-inches in any dimension shall be removed from the work site and disposed of by the contractor at his expense.
- C-8.7. Class "G" Backfill: The trench shall be backfilled with three-quarter-inch ($\frac{3}{4}$ ") minus crushed rock to six inches (6") above the top of the pipe. Place cement slurry per Juridical Road Authority approved mix backfill to the top of the required pavement replacement. Allow the slurry to set, and then remove to pavement depth. This item shall include the removal and disposal from the work site of the excavated material by the contractor at his expense.
- C-8.8. Compaction: All classes of trench backfill shall be compacted to the controlling agency's (e.g., City of Medford, Jackson County, ODOT) standard and is the responsibility of the contractor. Certified testing of compaction efforts shall be done by the contractor at his cost when requested by MWC inspection personnel.
- C-9. Excess Excavated Material: All excess or unsuitable excavated materials shall be hauled and disposed of by the contractor at approved locations or as designated by the Engineering Division.

- C-10. Roads, Street, and Driveway Crossings: The contractor shall obey all rules and regulations of the County, City, and State authorities regarding the closing of public streets or highways to the use of public traffic.

The work shall be carried out so as to cause a minimum of dislocation of normal commercial pursuits. Traffic must be kept open on those roads and streets where no detour is possible. The contractor shall, without further or other order, provide, erect, and maintain at all times during the progress or temporary suspension of the work, suitable barricades, fences, signs or other adequate protection, and shall provide, keep, and maintain such danger lights, signals, and a minimum of two flagmen unless approved otherwise by the Engineering Division to ensure the safety of the public as well as those engaged in connection with the work. All barricades and obstructions shall be protected by signal lights which shall be suitably distributed across and along the roadway, and shall be kept burning from one hour before sunset until one hour after sunrise and at such other times as vision is obscured by fog, smoke or dust. All barricades shall be of substantial construction.

- C-11. Permits and Easements: Where the trench is to be dug within a right-of-way obtained by permit or easement, the contractor shall acquaint himself with the requirements of the permit or easement, shall confine his operations to the area within the permit or easement, and shall obtain from the permit or easement grantor at the completion of the construction a release indicating that the work has been satisfactorily completed in accordance with the terms of the permit or easement. Should it be found impossible for the contractor to obtain any of the required releases either because of the absence of the grantor or because of impractical demands by the grantor, then the Engineering Division may waive this requirement, if, in the Engineering Division's opinion, the contractor has fulfilled his obligations. The contractor shall notify the owners of these properties 48 hours in advance of the time when construction will be started.

- C-12. Interfering Structures and Utilities: The contractor shall exercise all possible caution to prevent damage to existing structures and utilities whether above ground or underground. An attempt has been made to show these structures and utilities on the Plans or to indicate their presence in the Detail Specifications. While the information has been compiled from the best possible sources, its completeness and accuracy cannot be guaranteed, and it is presented simply as a guide to possible difficulties. The contractor shall notify all utility offices concerned at least 48 hours in advance of construction operations in which a utility's facilities may be involved. This shall include but not be limited to irrigation, sewer, telephone, electric, oil, gas, and television services.

It shall be the contractor's responsibility to locate and expose all existing underground structures and utilities in advance of the trench excavation. Any structures or utilities damaged by the work shall be repaired or replaced in a condition equal to, or better than, the condition prior to the damage.

The contractor shall remove and replace such small miscellaneous structures as culverts, fences, mail boxes, and sign posts at his own expense. The contractor shall replace structures in a condition as good as, or better than, their original condition.

If interfering power poles, telephone poles, guy wires, or anchors are encountered, the contractor shall notify the Engineering Division at least 12 days in advance of construction to permit arrangements with the utility company for protection or relocation of the structure. Such structures will not be considered to interfere unless they are within three feet (3') of the trench wall.

If the contractor encounters existing structures which will prevent the construction of the pipe line, and which are not properly shown on the Plans, he shall notify the Engineering Division before continuing with the construction in order that they may make such field revisions as necessary to avoid conflict with the existing structures. If the contractor shall fail to so notify when an existing structure is encountered, but shall proceed with the construction despite this interference, he shall do so at his own risk. When the location of the pipe line as shown on the plans will prohibit the restoration of an existing structure to its original condition, he shall notify the Engineering Division in order that a field location may be made to avoid the conflict.

- C-13. Field Relocation: During the progress of construction, it is expected that minor relocations of the line will be necessary. Such relocations shall be made only by direction of the Engineering Division.
- C-14. Obstructions: This item shall refer to obstructions which may be removed and do not require replacement. Obstructions to the construction of the trench such as, but not limited to tree roots, stumps, abandoned piling, abandoned concrete structures, logs, and debris of all types.
- C-15. Excavation across Cultivated Land: When excavating through cultivated land, the topsoil shall be removed and stockpiled on one side of the trench and the subsoil piled on the other. When the trench is to be backfilled with the excavated materials, care shall be taken to avoid mixing the excavated subsoil with the topsoil. If the contractor cannot avoid mixing of the materials, he shall, at his own expense, import approved top-soil for backfill to a depth equal to the surrounding area, but not less than 12 inches (12"). Backfill shall be such that the finished surface of the trench and surrounding area will be as nearly as practicable to its original condition.
- C-16. Clearing the Right-of-Way: Clearing of the entire right-of-way shall be completed prior to the start of the trenching and/or service installations. Trees and brush shall be cut as near to the surface of the ground as practicable and piled for disposal. Disposal shall be by removal unless otherwise approved by the Engineering Division. Under no condition shall excavated materials be permitted to cover brush or trees prior to clearing.
- C-17. Pavement Removal: Unless otherwise noted in the plans, where trenches are to be dug through paved streets or driveways, the pavement shall be cut to a straight line on each side of the trench with a pavement saw or other approved equipment. The width of the pavement cutout shall be 12 inches (12") greater (6" each side of the trench or as directed by the road authority) than the minimum width required for the installation of the pipe. The contractor shall so conduct the pavement removal operations as to cause the minimum damage possible to the

adjacent pavement. After the trench has been backfilled, the pavement cut shall be filled with gravel or cold mix (depending on surface approval agency) and shall be maintained level with the adjoining pavement without bumps or chuck holes until the pavement is finally patched.

II A

STANDARD SPECIFICATIONS FOR DUCTILE IRON PIPE, DUCTILE IRON FITTINGS, VALVES AND FIRE HYDRANTS

INDEX

A. SCOPE

B. MATERIALS

- B-1. Ductile Iron Fittings
 - B-1.1. Flanged Fittings
- B-2. Ductile Iron Fittings (Compact)
- B-3. Ductile Iron Pipe
 - B-3.1. Mechanical Joint Pipe
 - B-3.2. Push-on Joint Pipe
 - B-3.3. Flanged Joint Pipe
 - B-3.4. Restrained Joint Pipe
 - B-3.5. Push-on Joint Pipe with 5 Degree Deflection
 - B-3.6. Poly Pigs
- B-4. Butterfly Valves
- B-5. Gate Valves & Tapping Valves
 - B-5.1. 4" through 12" Valves
- B-6. Valve Boxes
- B-7. Fire Hydrant Assemblies
 - B-7.1. Fire Hydrants
 - B-7.2. Auxiliary Valves
 - B-7.3. Valve Box for Auxiliary Valve
 - B-7.4. Joint Restraint Glands
 - B-7.5. Tapping Sleeves & Tapping Saddles
 - B-7.5.1. Tapping Sleeves - 4 through 12 Inches
 - B-7.5.2. Tapping Saddles - 14 Inches & Larger
- B-8. Couplings

C. WORKMANSHIP

- C-1. Preparation of Trenches
 - C-1.1. Grade
 - C-1.2. Bell (Joint) Holes
 - C-1.3. Removal of Water

- C-2. Laying
 - C-2.1. Distributing Pipe
 - C-2.2. Handling Material
 - C-2.3. Cleaning Pipe and Fittings
 - C-2.4. Placing of Pipe in the Trench
 - C-2.5. Number of Pipe Laid Before Jointing
 - C-2.5.1. Mechanical Joint and Push-on Joint Pipe
 - C-2.6. Preventing Trench Water from Entering Pipe
 - C-2.7. Cutting Pipe
 - C-2.8. Bell End to face Direction of Laying
 - C-2.9. Permissible Deflection at Joints
 - C-2.10. Alignment
 - C-2.11. Unsuitable Conditions for Laying Pipe

- C-3. Jointing of Pipe
 - C-3.1. Jointing Mechanical Joint Pipe
 - C-3.2. Jointing Push-on Joint and Restrained Joint Pipe
 - C-3.3. Jointing Flanged Pipe and Fittings

- C-4. Setting Valves, Fittings, and Couplings
 - C-4.1. General
 - C-4.2. Location of Valves
 - C-4.3. Valve Boxes
 - C-4.4. Use of Steel Materials

- C-5. Setting Hydrants
 - C-5.1. Locations
 - C-5.2. Position
 - C-5.3. Connection to Main
 - C-5.4. Hydrant Installation

- C-6. Anchorage
 - C-6.1. Limiting Pipe Diameter and Degree of Bend
 - C-6.2. Thrust Blocking
 - C-6.3. Mechanical Joint Retainer Glands
 - C-6.4. Special Restrained Joints
 - C-6.5. Anchorage of Hydrants

- C-7. Flushing

- C-8. Sewer Crossings

- C-9. Hydrostatic Tests
 - C-9.1. Duration
 - C-9.2. Expelling Air
 - C-9.3. Procedure
 - C-9.4. Leakage
 - C-9.5. Correction of Excessive Leakage
 - C-9.6. Visible Leaks

- C-10. Installation of Poly Pigs

IIA

STANDARD SPECIFICATIONS FOR DUCTILE IRON PIPE, DUCTILE IRON FITTINGS, VALVES AND FIRE HYDRANTS

Reference herein is made to standards, tests, methods and specifications of research and technical organizations as follows:

ASTM American Society for Testing Materials
AWWA American Water Works Association
ANSI American National Standards Institute

Reference to ASTM, AWWA or ANSI shall be understood to mean, in all cases, the standard or specification of latest revision unless otherwise stated in the Detail specifications.

A. SCOPE: This standard specification shall cover the materials and workmanship for the installation of ductile iron fittings, valves, and fire hydrant assemblies.

B. MATERIALS

Item Standard Specification, Test or Method Designation

B-0.	Ductile Iron Pipe General	
B-1.	Ductile Iron Fittings	AWWA C153 and C111
B-2.	Ductile Iron Fittings (compact)	ANSI/AWWA C153/A21.53
B-3.	Ductile Iron Pipe	ANSI/AWWA C151/A21.51, TJ and MJ x TJ ANSI/AWWA C111/A21.11, MJ
B-4.	Rubber-seated Butterfly Valves	AWWA C504
B-5.	Resilient-Seated Gate Valves, 3 through 12 NPS, for Water & Sewer Systems	AWWA C509
	Protective Interior Coating for Valves	AWWA C550
B-6.	Valve Boxes	ASTM A48 CL35B
B-7.	Fire Hydrants for Ordinary Water Service	AWWA C502
B-0.	Ductile Iron Pipe General	

All ductile iron pipe shall be cast, cleaned, cement lined, coated, tested, and certified at a single manufacturing facility with all manufacturing units contiguous to one another.

An Affidavit shall be provided with each shipment stating that ductile iron pipe was cast from a raw material source consisting of at least 75% recycled ferrous metals. This Affidavit shall be signed by a Professional Engineer registered in the state of the source manufacturing facility.

All ductile iron pipe shall be cement mortar lined meeting the requirements of AWWA C104. Cement mortar lining shall be applied and cured in a manufacturing unit contiguous to the pipe casting unit.

The ductile iron pipe manufacturer and supplier shall certify that the source manufacturing facility has been producing ductile iron pipe of the specified diameters, dimensions, and Standards for a period of not less than ten years. This Affidavit shall be signed by a Professional Engineer registered in the state of the source manufacturing facility.

All testing of ductile iron pipe required by AWWA A21.51 shall be conducted in testing and laboratory facilities located in the United States and under the auspices of United States laws and regulations. Such test results shall be certified by a Professional Engineer registered in the state of the source manufacturing facility.

An Affidavit shall be provided with each pipe shipment stating that for all ductile iron pipe shipped all federal (United States) OSHA, EEO and environmental requirements including Clean Air and Clean Water Acts have been met during the course of pipe production. This Affidavit shall be signed by a Professional Engineer registered in the state of the source manufacturing facility.

All ductile iron pipe manufacturing source facilities operated by the producing manufacturer and / or supplier certainly including, but not limited to, the source manufacturing facility, shall be ISO 9001 and 9002 certified. An Affidavit stating such shall be provided by the manufacturer and attested to by an officer of the supplying company, if not supplied by the manufacturing company. This Affidavit shall be signed by a Professional Engineer registered in the state of the source manufacturing facility.

The ductile iron pipe manufacturer shall provide certification that the products manufactured in the source facility have ten-year compliance with ANSI/NSF 61, Drinking Water System Components-Health Effects. Such certification shall be signed by a Professional Engineer registered in the state of the source manufacturing facility.

The ductile iron pipe manufacturer and supplier shall certify that pipe shipments comply with the provisions of the Buy American Act as contained in the Supplemental Provisions of the specifications of the Bureau of Reclamation.

Such certification shall be signed by a Professional Engineer registered in the state of the source manufacturing facility.

B-1. Ductile Iron Fittings

B-1.1. Flanged Fittings: Flanged ductile iron fittings shall conform to AWWA C153 and C111. Flanges shall have bolt circles and bolt holes matching those ANSI B16.1., the pressure rating shall be 250 psi. Flange thickness

to be uniform on full circumference of flange and thickness as specified in AWWA C153, table 53.1 Bolts for joining cast iron flanges shall be carbon steel of at least Grade 5 with American Standard Regular unfinished hexagon heads and the nuts shall be of steel with American Standard Regular hexagon dimensions, all as specified in American Standard for Wrench Head Bolts and Nuts (ASME B18.1). Bolts and nuts shall be cadmium plated in sizes to and including 7/8" diameter. All bolts and nuts shall be threaded in accordance with American Standard for Screw Threads (ASME B1.1.), Coarse Thread Series, Class 2A and 2B fit. Gaskets shall be rubber Flange Tyte as manufactured by the United States Pipe & Foundry Company or approved equal. Cement-mortar lining is required on all fittings. Fittings shall be as manufactured by Tyler, Trinity Valley, U.S. Pipe, Pacific States Pipe, American, Griffin, and Union Foundry, or an approved equal.

B-2. Ductile Iron Fittings (Compact)

B-2.1. Mechanical Joint Fittings: Mechanical joint ductile iron compact fittings shall conform to AWWA C153. Joints shall conform to AWWA C111. Joint accessories shall be furnished with the fittings. Bolts shall be low-alloy steel or ductile iron in accordance with AWWA C111. The pressure rating shall be 350 psi. Fittings must be cement-mortar lined in accordance to AWWA C104. Fittings shall be as manufactured by Tyler, U.S. Pipe, Pacific States Pipe, American, Griffin, Union Foundry, or an approved equal.

B-3. Ductile Iron Pipe

B-3.1. Mechanical Joint Pipe: Mechanical joint ductile iron pipe shall conform to AWWA C151. Pipe with diameters of 12-inch (12") and smaller shall have a wall thickness of class 52. Pipe with diameters of 14-inch (14") and larger shall have a wall thickness of class 50. All pipe classes and styles shall be represented on Engineered plans. The pipe shall be standard thickness cement-mortar lined conforming to the requirements of AWWA C104 and shall be as manufactured by United States Pipe & Foundry Company, Pacific States Cast Iron Pipe Company, and American or approved equal. Joints shall conform to AWWA C111. United States Pipe & Foundry Company MJ / TJ pipe joints are approved. Joint accessories shall be furnished with the pipe. Bolts shall be low-alloy steel or ductile iron in accordance with AWWA C111.

B-3.2. Push-on Joint Pipe: Push-on ductile iron pipe shall conform to AWWA C151. Pipe with diameters of 12-inch (12") and smaller shall have a wall thickness of class 52. Pipe with diameters of 14-inch (14") and larger shall have a wall thickness of class 50. All pipe classes and styles shall be represented on Engineered plans. The pipe shall be cement-mortar lined conforming to the requirements of AWWA C104 and shall be as manufactured by United States Pipe & Foundry Company and by Pacific States Cast Iron Pipe Company, and American, or approved equal. Joints shall conform to AWWA C111, and shall be "Tyton" joint as manufactured by United States Pipe & Foundry Company and by Pacific States Cast

Iron Pipe Company or approved equal. United States Pipe & Foundry Company MJ/TJ pipe joints or an approved equal. The rubber ring gasket shall be suitable for the specified pipe sizes and pressures and shall be furnished with the pipe. A non-toxic vegetable soap lubricant shall be supplied in sufficient quantities for installing the pipe furnished. Fast-tite as manufactured by the Griffin Company may be substituted for "Tyton" joint pipe on contractor supplied and installed projects.

B-3.3. Flanged Joint Pipe: Flanged ductile iron pipe shall conform to AWWA C115. Pipe with diameters of 12-inch (12") and smaller shall have a wall thickness of class 52. Pipe with diameters of 14-inch (14") and larger shall have a wall thickness of class 50. All pipe classes and styles shall be represented on Engineered Design. The pipe shall be cement-mortar lined conforming to the requirements of AWWA C104 and shall be as manufactured by United States Pipe & Foundry Company and by Pacific States Cast Iron Pipe Company or approved equal. Bolts, gaskets, and installation shall be in accordance with the Appendix of AWWA C115. Flanges shall be ductile iron.

B-3.4. Restrained Joint Pipe: Restrained joint ductile iron pipe shall conform to AWWA C151. Pipe with diameters of 12-inch (12") and smaller shall have a wall thickness of class 52. Pipe with diameters of 14-inch (14") and larger shall have a wall thickness of class 50. All pipe classes and styles shall be represented on Engineered Design. The pipe shall be cement-mortar lined conforming to the requirements of AWWA C104 and shall be as manufactured by United States Pipe & Foundry Company and by Pacific States Cast Iron Pipe Company, and American or approved equal. The pipe shall be furnished with spigot ends and push-on joint bells suitable for transmitting the thrust created by a dead-end condition based on pipe diameter and a pressure of 150 psi. Restrained push-on joints shall be TR-Flex joint as manufactured by the U. S. Pipe & Foundry Company, Thrust-Lock as manufactured by Pacific States Cast Iron Pipe Company, or approved equal. All restraint ears, locking rings, etc. shall be installed. Restrained mechanical joints shall use joint restraint glands as specified in Section B-7.4. of these Specifications.

B-3.5. Push-on Joint Pipe with 5 Degree Deflection: Where required by the Plans, push-on joint pipe in sizes 20" and larger as specified in Item B-3.2. shall have sockets and spigots to permit a deflection of 5 degrees in the joint. Such pipe shall be suitably marked to distinguish it from other push-on joint pipe.

B-3.6. Poly Pigs: "Poly Pigs" shall be constructed of flexible open cell polyurethane foam and be wrapped with polyurethane spiral bands. They shall be able to pass through reductions of up to 60% of cross sectional area of nominal pipe. They shall have the ability to negotiate short radius bends, ells, tees, crosses, wyes, gate valves, ball valves, multi-dimensional piping and reduced port values. "Poly Pigs" shall be a municipal series, coated type, 5-7 lbs per cubic foot density, and generally be for a light cleaning or gauging application. MWC may specify use of bare type 5-7 lbs per cubic foot density pig for use prior to the use of the coated pig.

- B-4. Butterfly Valves (12" and larger): Butterfly valves shall be short bodied flanged or wafer type or mechanical joint ends when placed underground. They shall be epoxy coated and lined, rubber seated type and shall conform to AWWA C504, Class 150B, unless otherwise noted in the Detail Specifications. Butterfly valves shall be furnished with iron bodies. Flanges shall be drilled in accordance with ANSI-125 lb. standard. Mechanical joint ends shall conform to AWWA C111. Butterfly valves shall be suitable for direct burial and shall have direct burial, totally enclosed, integral manual operators which shall be fully gasketed and grease-packed and designed to withstand submersion in water to a pressure of 10 psi. The valves shall open with a counter-clockwise rotation of a 2-inch nut.

THE MINIMUM NUMBER OF TURNS FROM CLOSED TO OPEN POSITION SHALL BE NOT LESS THAN TWO TURNS PER INCH OF VALVE SIZE.

Only the following valves will be accepted:

M & H	Kennedy
Pratt	Mueller

- B-5. Gate Valves & Tapping Valves

- B-5.1. 4" - 12" Valves: Gate valves shall be epoxy coated resilient-seated gate valves with a full rubber encapsulated wedge and floating stem nut, with non-rising stem, "O" ring seals and two-inch square operating nut. 12" valve for tapping valve only see section B-4 for butterfly valves.

The valves shall open when turned counter-clockwise. All valves with mechanical joint connection shall be furnished with ductile iron nuts, bolts, glands and gaskets for mechanical joint connections. All valves shall have the manufacturer and date cast on the body. Gate valves shall conform to AWWA C509 Standards.

Only the following valves will be accepted:

M & H	Kennedy Valve
Clow	Mueller

Flange drillings shall be ANSI 125-lb. standard. Mechanical joints shall conform to AWWA C111.

- B-6. Valve Boxes: Valve boxes shall be the three-piece sliding adjustable made in the U.S.A "Medford" type consisting of a lid, box section, and steel casing extension. Valve box and lid shall be made of ductile iron as manufactured by East Jordan Iron Works valve lid Series 6800 CL35 and EJIW valve box part Series 8555 16" tall or approved equal. The valve box lid shall be labeled "Water" and shall fit the valve box snugly and shall not rock on its seat. The steel well casing shall be of 12-gauge wall thickness, with outside diameter of 6 inches WSP bare or approved equal. The steel well casing shall be within 6" of finished grade.

B-7. Fire Hydrant Assemblies: Fire hydrant assemblies shall include the fire hydrant, auxiliary gate valve, valve box, and materials for anchorage such as mechanical joint restraint glands.

B-7.1. Fire Hydrants: Fire hydrants shall be of the compression type conforming to AWWA C502 and shall have 5-inch valve opening with 6-inch mechanical joint and connection. The hydrant shall open when turned counter-clockwise and shall have two 2-1/2" hose nozzles and one 4-1/2" pumper nozzle. The nozzles and operating nut shall be National Standard. The hydrants shall be painted a chrome-yellow color and shall be equipped with a safety break flange located above the ground line. All hydrants shall have corrosion resistance protection on the interior of the hydrant shoe; coating shall conform to AWWA C550. The depth of bury of the hydrants shall be such that when the hydrant is set at the grade indicated on the plans that the ground line marked on the hydrant shall be at the sidewalk or ground surface. Mechanical joint and Flange ends shall have full wall ductile iron thickness elbow that is equal to AWWA C-509 flange standard. Only the following hydrants manufactured by the Mueller Company and Kennedy Valve Company will be accepted:

Mueller Centurion A423 Kennedy Guardian (K-81D)

Tables below has specific manufacturer part number for bury depth for MJ or flange type.

Mueller Centurion (A423) (Flange)	
Depth of Bury	Mueller #
3' 0"	423-532668
3' 6"	423-532669
4' 0"	423-532670
4' 6"	423-532671

Kennedy Guardian (K81D) (Flange)	
Depth of Bury	Kennedy#
3' 0"	1546230615102YMOR
3' 6"	1546236615102YMOR
4' 0"	1546240615102YMOR
4' 6"	1546246615102YMOR

Mueller Centurion (A423) (MJ)	
Depth of Bury	Mueller #
2' 6"	423-532115
3' 0"	423-532116
3' 6"	423-532117
4' 0"	423-532118
4' 6"	423-532119
5' 0"	423-532120

Kennedy Guardian (K81D) (MJ)	
Depth of Bury	Kennedy#
2' 6"	1546325615102YMOR
3' 0"	1546330615102YMOR
3' 6"	1546335615102YMOR
4' 0"	1546340615102YMOR
4' 6"	1546345615102YMOR
5' 0"	1546350615102YMOR

In general, MWC only allows a 3' 6" bury. Any proposed hydrant installation below 3' 6" bury depth must be approved by MWC. Hydrant bury depths from 4' 0" to 5' 0" may be used as field conditions or design dictate with MWC approval.

B-7.2. Auxiliary Valves: The fire hydrant auxiliary valves shall have mechanical joint ends and shall be gate valves conforming to the above Item B-5. The auxiliary valve shall be located adjacent to the hydrant branch tee which shall have a swivel branch.

B-7.3. Valve Box for Auxiliary Valve: The valve boxes for the hydrant auxiliary valves shall conform to the above Item B-6.

B-7.4. Joint Restraint Glands: Joint restraint glands used for thrust anchorage in place of regular cast iron mechanical joint glands shall be ductile iron mechanical joint Megalug, as manufactured by EBAA Iron, Roma Grip by Romac, Ford 1400 Series Restraint Gland, or approved equal. The minimum number of set screws by size of gland shall be as follows:

4" - 2	14" - 10
6" - 3	16" - 12
8" - 4	18" - 12
10" - 6	20" - 14
12" - 8	24" - 16

B-7.5. Tapping Sleeves and Saddles

B-7.5.1. Tapping sleeves (2-piece) for Ductile Iron pipe only sizes 4" through 12" shall be U.S. Pipe T-28 Dual compression seal, Kennedy Valve Manufacturing Co. square seal, Mueller outlet seal, Dresser style 974, ROMAC FTS-420, Smith Blair 622, JCM 412, and Tyler

B-7.5.2. Tapping sleeves (5-piece) shall be mechanical joint type for all cast iron pipe and ductile iron pipe size on size manufactured by Mueller Co, H-615, M & H Valve Fitting Co., and Tyler

B-7.5.3. Tapping saddles for 14" pipe and larger for Ductile Iron shall be U.S. Pipe ductile iron saddle castings conforming to ANSI A21.10 or as manufactured by the American Cast Iron Pipe Co. The saddle straps, including threaded ends and nuts, shall be U. S. alloy having a minimum yield of 45,000 psi, or approved equal. In lieu of the above tapping saddle, a U. S. Pipe Dual compression seal tapping sleeve or a cast iron mechanical joint type by an approved manufacturer may be used.

B-7.5.4. Tapping saddles for 14" pipe and larger for Cast Iron shall be U.S. Pipe ductile iron saddle castings conforming to ANSI A21.10 or as manufactured by the American Cast Iron Pipe Co. The saddle straps, including threaded ends and nuts, shall be U.S. alloy having a minimum yield of 45,000 psi, or approved equal. In lieu of the above tapping saddle, a U.S. Pipe Dual compression seal tapping sleeve or a mechanical joint type by an approved manufacturer may be used.

All connections to a cement-lined and coated pipe will be made by the MWC with cooperation and assistance from the Contractor on excavation, backfill, temporary plating, and traffic control.

- B-8. Couplings: All couplings shall meet current AWWA Standards. All center and end rings shall be ductile iron on 4" and larger pipe and meet acceptable ASTM Standards except where specifically stated otherwise. Gaskets shall be made of materials compounded for water service. Nuts and bolts shall be corrosion resistant, high strength, low-alloy steel with heavy hex nuts, meeting requirements of AWWA C111. Couplings shall be as manufactured by Smith Blair, Romac 501, Ford, or approved equal.

C. WORKMANSHIP

C-1. Preparation of Trenches

C-1.1. Grade: The bottom of the trench shall be excavated to the line and grade to which the pipe is to be laid, with proper allowance for pipe thickness and for gravel bedding as specified. The trench bottom shall form a continuous and uniform bearing and support for the pipe on bedding material at every point between bell holes, except that for a maximum distance of 18" near the center of the pipe, the bedding may be disturbed for the removal of lifting tackle. Where the trench is excavated in rock it is especially important that a minimum of three (3) inches of bedding material be used to obtain uniform bearing and support for the pipe.

C-1.2. Bell (Joint) Holes: At the location of each joint, bell (joint) holes of ample dimensions shall be dug in the bedding as necessary to permit the joint to be made properly and to permit easy visual inspection of the entire joint.

C-1.3. Removal of Water: The contractor shall at all times provide and maintain ample means and devices to remove and dispose of all water entering the trench excavation during the process of laying the pipe.

C-2. Laying

C-2.1. Distributing Pipe: Material shall be distributed on the job no faster than can be used to good advantage. In general, no more than one week's supply of material shall be distributed in advance of the laying

C-2.2. Handling Material: Proper implements, tools and facilities satisfactory to the Engineering Division shall be provided and used by the contractor for the safe and convenient prosecution of the work. All pipe, fittings, valves, and hydrants shall be carefully lowered into the trench, piece by piece, by means of a crane or other suitable equipment, in such a manner as to prevent damage to the pipeline materials and protective coatings and linings. Under no circumstances shall pipeline materials be dropped or dumped into the trench.

C-2.3. Cleaning Pipe and Fittings: All lumps, blisters and excess coating shall be removed from the bell and spigot ends of each pipe. The outside of the spigot and the inside of the bell shall be wiped clean and dry and free from dirt, grease and foreign matter before the pipe is laid.

C-2.4. Placing of Pipe in the Trench: Every precaution shall be taken to prevent foreign material from entering the pipe while it is being placed in the line. If the pipe laying crew cannot put the pipe into the trench and in place without getting earth into it, the Engineering Division may require that, before lowering the pipe into the trench, a heavy, tightly woven canvas bag of suitable size shall be placed over each end and left there until the connection is to be made to the adjacent pipe. During the laying operations, no debris, tools, clothing or other materials shall be placed in the pipe.

C-2.5. Number of Pipes Laid Before Jointing

C-2.5.1. Mechanical Joint and Push-On Joint Pipe: Mechanical joint pipe and push-on joint pipe shall be connected as hereinafter specified as soon as they are placed in the trench.

C-2.6. Preventing Trench Water from Entering Pipe: At times when pipe laying is not in progress, the open ends of pipe shall be closed by a water-tight plug or other means approved by the Engineering Division, and no trench water shall be permitted to enter the pipe. These provisions shall apply during the noon hour as well as overnight. If water is in the trench, the seal shall remain in place until the trench is pumped completely dry.

C-2.7. Cutting Pipe: The cutting of pipe for inserting valves, fittings or closure pieces shall be done in a neat and workmanlike manner without damage to the pipe or lining and so as to leave a smooth end at right angles to the axis of the pipe.

Acceptable methods of cutting cast iron pipe are sawing with a band or powered hack saw or with a portable, gasoline engine driven abrasive saw. Cast iron pipe may also be cut with a lathe or portable milling saw. When approved by the Engineering Division, cast iron pipe may also be cut by breaking with the use of rolling pipe cutters, hydraulically actuated cutters such as "Wheeler" cutters or with the use of a sledge and cold cutter.

Acceptable methods of cutting ductile iron pipe are only those done by sawing or milling. The flame cutting of cast iron or ductile iron pipe by means of an oxyacetylene torch shall not be allowed.

When mechanical joint or push-on joint pipe is cut in the field, it shall be cut as recommended by the pipe manufacturer, and the cut end shall be reconditioned so that it may be used for the next joint. On push-on joint pipe, the outside of the cut shall be ground back or dressed as recommended by the pipe manufacturer and approved by the Engineering Division.

C-2.8. Bell End to Face Direction of Laying: Unless otherwise directed, pipe shall be laid with bell end facing in the direction of the laying; and for lines on an appreciable slope, bells shall (at the direction of the Engineering Division) face upgrade.

C-2.9. Permissible Deflection at Joints: Wherever it is necessary to deflect pipe from a straight line, either in the vertical or horizontal plane, to avoid obstructions or plumb stems or where long-radius curves are permitted, the amount of deflection allowed shall not exceed that approved by the Engineering Division. Maximum permitted deflections are indicated hereinafter in Tables I and II except that deflection up to 5 degrees may be obtained in special 5 degree deflection push-on pipe specified in Item B-3.5.

-- CONTINUED ON THE NEXT PAGE --

TABLE I			
MAXIMUM DEFLECTION OF MECHANICAL JOINT PIPE			
Safe Deflection for 150 Pounds Pressure			
Size of Pipe in Inches	Maximum Joint Deflection in Degrees	Deflection in Inches with Pipe Length of 18'	Approx. Radius in Feet of Curve Produced by Succession of Joints Length in Feet - 18'
4	8	29	120
6	7	25	140
8	5	19	195
10	5	19	195
12	5	19	195
14	4	15	285
16	4	15	285
18	3	11	340
20	3	11	340
24	3	11	340
30	3	11	340
36	3	11	340
*For pressures above 150 pounds, reduce the tabulated deflection by 10% for each 150			

TABLE II			
MAXIMUM PERMISSIBLE DEFLECTION IN LAYING PUSH-ON JOINT PIPE			
Size of Pipe in Inches	Maximum Joint Deflection in Degrees	Deflection in Inches	
		18 Feet	20 Feet
4	5	19	21
6	5	19	21
8	5	19	21
10	5	19	21
12	5	19	21
14	4	15	17
16	4	15	17
18	3	11	12
20	3	11	12
24	3	11	12
30	3	11	12
36	3	11	12

C-2.10. Alignment: Pipe lines intended to be straight shall be so laid, and in no case shall a deviation from the straight line at any joint exceed one (1) inch.

C-2.11. Unsuitable Conditions for Laying Pipe: No pipe shall be laid in water or when in the opinion of the Engineering Division, trench conditions are unsuitable.

C-3. Jointing of Pipe

C-3.1. Jointing Mechanical Joint Pipe: Mechanical joint ductile iron pipe shall be installed in accordance with manufacturer's recommendations as approved by the Engineering Division. In general, the procedure shall be as hereinafter specified. The ends of the pipe shall be cleaned of all dirt, mud, and foreign matter by washing with water and scrubbing vigorously with a wire brush, after which the gland and gasket shall be slipped on the plain end. The ends of ductile iron pipes 16-inches and larger and the rubber gaskets shall be lubricated with gasket lubricant of the type used for push-on joints. The end of the pipe shall then be guided carefully into the bell of the pipe previously laid. The spigot shall be centrally located in the bell, the gasket placed in position, and the bolts inserted in the holes.

When tightening bolts, the gland should be brought up toward the flange evenly, maintaining approximately the same distance between the gland and the face of the flange at all points around the socket. This shall be done by partially tightening the bottom bolt first, then the top bolt, next the bolts at either side, and last, the remaining bolts. This cycle should be repeated until all bolts are within the required range of torque. (In larger sizes, 24-inch through 48-inch, as many as 5 repetitions may be required.) If effective sealing is not attained at the maximum torque, the joint shall be disassembled and reassembled after thorough cleaning. Over stressing of bolts to compensate for poor installation practice shall be avoided.

C-3.2. Jointing Push-on Joint, Mechanical Joint-Tyton Joint & Restrained Joint Pipe: Ductile iron pipe with push-on type, mechanical joint-tyton joint and restrained type joints shall be laid and jointed in strict accordance with the manufacturer's recommendations as approved by the Engineering Division and in accordance with the requirements of the Detail Specifications. The contractor shall provide all special tools and devices such as special jacks, chokers, and similar items required for the installation. Lubricant for the pipe gaskets shall be furnished by the pipe manufacturer, and no substitutes will be permitted under any circumstances.

C-3.3. Jointing Flanged Pipe & Fittings: The jointing of flanged pipe and fittings shall be in accordance with the Appendix of AWWA C115. Care shall be taken to evenly tighten all bolts and to avoid overstressing the bolts or flanges.

C-4. Setting Valves, Fittings and Couplings

C-4.1. General: Valves, fittings, plugs, couplings, and caps shall be set and jointed to pipe in the manner hereinbefore specified for cleaning, laying, and jointing pipe. All valves shall be operated through a full closed and full open position. Valves shall be checked for proper direction of operation.

C-4.2. Location of Valves: Valves in water mains shall, where possible, be located on the street property lines extended unless otherwise shown on the plans.

C-4.3. Valve Boxes: A valve box shall be provided for every valve. Valve box steel casing extensions shall be cut to proper length so that the valve box does not ride on the extension when set at finish grade and that the top section will slide over the extension for a minimum distance of 8 inches. Valve casing shall be within eight (8) inches of finished grade. The valve box shall be centered and plumb over the valve wrench nut with the box cover flush with the finish surface. When valve boxes are set in paved streets, particular care shall be given to the placing of asphaltic concrete around the box to assure compaction of the paving materials under the

shoulder of the box. When the distance from the top of the valve operating nut to the top of the valve box exceeds 36 inches, an extension to the operating nut shall be furnished and installed by MWC at the developer's expense.

C-4.4. Use of Steel Material: All steel coupling, tapping sleeves, or other steel products must be wrapped with 8 mil thick polyethylene film in accordance with AWWA C105 or powder coated as determined by MWC prior to backfill. Caution must be exercised to insure this coating is not damaged during the backfill operation. Insulators shall be used on all steel main bolt connections.

C-5. Setting Hydrants

C-5.1. Locations: Hydrants shall be located as shown on the plans or as directed by the Engineering Division in a manner to provide complete accessibility and to minimize the possibility of damage from vehicles or injury to pedestrians.

C-5.2. Position: All hydrants shall stand plumb and shall have the pumper nozzle facing the curb or center of the street. All chains shall be removed from hydrants. Hydrants shall be set with the ground line marked on the hydrant at finish grade or as directed by the Engineering Division.

C-5.3. Connection to Main: Each hydrant shall be connected to the main with a 6-inch ductile iron branch controlled by an independent 6-inch gate valve.

C-5.4. Hydrant Installation: All hydrants shall be set on a concrete base at least 8 inches square and 4 inches deep and shall be backfilled to three (3) inches above the bottom of hydrant flange with 3/4-inch to 1-inch maximum round drain rock. The remaining trench depth shall be backfilled with 3/4-inch minus crushed rock placed in 8-inch layers and compacted to 95% density. Such drain rock and compacted 3/4-inch minus shall extend a minimum of 18 inches around all sides of the hydrant.

C-6. Anchorage

C-6.1. Limiting Pipe Diameter and Degree of Bend: On all pipelines 4 inches in diameter or larger, all tees, plugs, caps, bends and other locations where unbalanced forces exist shall be securely anchored by suitable thrust blocking. No vertical bend thrust blocking will be allowed but must be anchored with MJ pipe and restrained joints.

C-6.2. Thrust Blocking: Reaction or thrust blocking shall consist of concrete of a mix not leaner than five sacks of cement per cubic yard of concrete and having a compressive strength of not less than 2,500 pounds per square inch. Thrust blocks shall not be backfilled for 12 hours unless authorized by Engineering Division. Blocking shall be placed between the undisturbed ground and the fittings to be anchored. Concrete blocking shall be formed with plywood and bear against solid undisturbed earth of

the sides and bottom of the trench excavation. The quantity of concrete and the area of bearing for the pipe shall be as shown on the Plans or as directed by the Engineer. Drawing 109 in the Appendix shows the typical thrust block diagrams and the minimum bearing area. Caution must be exercised by the contractor to be sure the bearing capacity of the soil is at least 1500 psf before using the table. The blocking shall be so placed that, unless specifically shown otherwise on the plans, the pipe and fitting joints will be accessible to repairs. Eight (8.0) mil plastic shall be placed between all concrete and fitting or pipe.

C-6.3. Mechanical Joint Restraint Glands: With suitable conditions, anchorage may be obtained with the use of ductile iron mechanical joint restraint glands with set screws as specified in item B-7.4. in place of the follower glands normally furnished for pipe and fittings. The installation of the glands shall be in accordance with the manufacturer's recommendations. Care shall be taken to see that the mechanical joint bolts are completely tightened and that there will be no further deflection before tightening the set screws.

C-6.4. Special Restrained Joints: With suitable conditions and with approval of the Engineering Division for each installation, cast iron or ductile iron pipe and fittings with special restraining mechanical or push-on joints which permit tension through the joints thus developing anchorage with opposing forces of pipe to backfill friction may be used.

C-6.5. Anchorage of Hydrants: Hydrants shall be anchored by means of mechanical joint restraint glands as specified in Item C-7.4. above unless otherwise directed by the Engineering Division.

C-7. Flushing: As soon as the pipe is laid, service taps made, and before it is connected to the distribution system at more than one point, it shall be flushed through an open end of the pipe and at all blow-offs and fire hydrants. The contractor shall provide sufficient trench pumping capacity to pump out the water flushed from the open end and shall provide labor to assist MWC's representatives in flushing operations.

After the pipe has been completely laid and connected to the distribution system, and after testing and disinfection has been completed, a complete flushing through all hydrants and dead-ends shall be done. The Contractor shall make all portions of the line, including dead-ends, accessible to MWC personnel and vehicles.

C-8. Sewer Crossings: Sewer crossings shall be as per current Oregon Health Division Public Water Systems/Oregon Administrative Rules, Chapter 333 unless modified by this section. In situations where a water line or service line and a sanitary sewer main or sewer lateral cross, the separation between the two shall be as follows:

(a) Wherever possible, the bottom of the water line shall be 1.5 feet or more above the top of the sewer line and one full length of the water line shall be centered at the crossing;

- (b) Where the water line crosses over the sewer line but with a clearance of less than 1.5 feet, the sewer line shall be exposed to the sewer line joints on both sides of the crossing to permit examination of the sewer pipe. If the sewer pipe is in good condition, and there is no evidence of leakage from the sewer line, the 1.5-foot separation may be reduced to 8 inches. The contractor must center one length of water line at the crossing. If the Engineering Division determines that the conditions are not favorable or finds evidence of leakage from the sewer line, the sewer line shall be replaced with a full length of pipe centered at the crossing point, of PVC pressure pipe (AWWA Standard C900), or ductile iron Class 50 (AWWA C51).
- (c) Where the water line crosses under the sewer line, the water supplier shall expose the sewer line and examine it as indicated in (b) of this section. If conditions are favorable and there is no evidence of leakage from the sewer line, the sewer line may be left in place, but must be supported with a reinforced concrete pier for preventing settlement when it spans the water line trench, and special precautions must be taken to assure that the backfill material over the water line in the vicinity of the crossing is thoroughly tamped in order to prevent settlement which could result in the leakage of sewage. In this situation, the contractor must center one length of the water line at the crossing. If MWC determines that conditions are not favorable or finds evidence of leakage from the sewer line, the provisions of (b) of this section apply.

Whenever a sanitary sewer is uncovered and the sewer pipe leaks or is broken, then ductile iron water pipe (not cast iron soil pipe) or PVC water pipe conforming to AWWA Standard C900 must be used to replace the sewer pipe. One full length of the ductile iron pipe or PVC pipe shall be centered at the water pipeline crossing so that the joints of both pipes shall be at least 9 feet from the crossing centerline. Care must be taken to ensure smooth invert at the new sewer joints. The contractor shall make the repair at his own expense, including pipe trenching, backfill, and asphaltic pavement cutting and replacing necessary to install the 18-foot length of ductile iron pipe or 20-foot length of PVC pipe.

C-9. Hydrostatic Tests: NO TESTING OF WATER MAINS WILL BE DONE UNLESS THERE IS A MINIMUM OF 18 INCHES COVER OVER THE PIPE.

Pressure and leakage tests shall be made on all newly-laid pipe or any valved section of it, or both, unless otherwise specified in the Detail Specifications. MWC will conduct the tests, will furnish gauges for the tests, and will make all taps into the pipe. The contractor shall furnish all necessary assistance for conducting the test and he shall, if required, furnish the test pump, pipe connection, hoses, valves, and suitable graduated containers for measurement of the water used for testing.

The tests shall be conducted after the trench has been backfilled sufficiently to prevent movement of the pipe during testing and flushing. The joints may be left exposed for inspection. Where any section of pipe is provided with concrete

reaction blocking, the pressure test shall not be made until at least five (5) days have elapsed after the concrete reaction blocking is installed. If high-early cement is used for the concrete thrust blocking, the time may be cut to two (2) days instead of five (5) as previously specified.

The pressure test shall be conducted in the following manner. After the pipe has been backfilled or partially backfilled as hereinbefore specified, the pipe shall be filled with water. Unless stated otherwise in the Detail Specifications, the test pressure shall be 1½ times the normal static pressure, but not less than 150 pounds per square inch.

C-9.1. Duration: The duration of each pressure test shall be 60 minutes unless otherwise authorized by the Engineering Division.

C-9.2. Expelling Air: Before applying the specified test pressure, all air shall be expelled from the pipe.

C-9.3. Procedure: Each valved section of pipe shall be slowly filled with water to replace any lost; and the specified test pressure, measured at the point of lowest elevation, shall be applied by means of a pump connected to the pipe in a satisfactory manner.

The pump shall then be valved off, and the pressure shall be held in the line for the test period. At the end of the test period, the pump shall be operated until the test pressure is again attained. The pump suction shall be in a bucket, barrel, or similar device so that the amount of water required to restore the test pressure may be measured accurately.

C-9.4. Leakage: Leakage shall be defined as the quantity of water necessary to restore the specified test pressure at the end of the test period. No pipe installation will be accepted until the leakage is less than the number of gallons per hour as determined by the formula following:

$$L = \frac{ND (P)^{1/2}}{7400}$$

in which:

- L = allowable leakage in gallons per hour
- N = number of joints in the length of pipe tested
- D = nominal diameter of pipe in inches
- P = average test pressure during the leakage test in pounds per square inch.

C-9.5. Correction of Excessive Leakage: Should any test of pipe laid disclose leakage greater than that allowed under Item C-9.4. above, the contractor shall, at his own expense, locate and repair the defective joints or pipe until the leakage is within the specified allowance.

C-9.6. Visible Leaks: All visible leaks and known leaks revealed by the test shall be repaired regardless of the total amount of leakage shown by the test.

- C-10. Installation of Poly Pigs: “Poly pigs” shall be supplied and installed by the contractor during installation of the pipeline. Number, sizes and locations shall be as determined by the Engineering Division. The “poly pigs” shall be moved through the pipeline system by the use of water pressure during flushing operations performed by MWC personnel, but after service taps have been made. All “poly pigs” shall be removed from the pipeline system by MWC prior to testing and disinfection. Used “poly pigs” become the property of MWC and their reuse determined by the inspector.

II B

STANDARD SPECIFICATIONS FOR STEEL PIPE AND FITTINGS, AN ALTERNATE PIPE FOR TRANSMISSION MAINS 42- INCHES AND LARGER

INDEX

A. SCOPE

B. MATERIALS

- B-0. Steel Pipe - General
 - B- 0.1. Application
 - B- 0.2. Specials and Fittings Definition
 - B- 0.3. Pipe Manufacturing Operations
 - B- 0.4. Inspection and testing of Pipe
 - B- 0.5. Environmental Regulations
 - B- 0.6. ISO 9110 and 9002 Certification
 - B- 0.7. NSF/ANSI 61 Compliance
 - B- 0.8. Buy American
 - B- 0.9. Diameter of Pipe Definition
 - B- 0.10. Permeation
 - B- 0.11. Submittal of Drawings and Calculations
 - B- 0.12. Line and Layout of Drawings
 - B- 0.13. Fabrication Drawings
 - B- 0.14. Calculation
 - B- 0.15. Test Results
 - B- 0.16. Affidavit of Compliance
 - B- 0.17. Furnish, Install and Test Corrosion Control System

- B-1. Steel Pipe
 - B- 1.1. Diameter and Quantity of Pipe
 - B- 1.2. Internal Design Pressure
 - B- 1.3. Hoop Tensile Design Stress
 - B- 1.4. Steel Minimum Yield Strength
 - B- 1.5. Minimum Steel Wall Thickness
 - B- 1.6. Steel Cylinder
 - B- 1.7. Pipe Length
 - B- 1.8. Marking Pipe
 - B- 1.9. Shipping and Handling

- B-2. Cement – Mortar Protective Lining and Coating for Steel Water Pipe
 - B-2.1. Lining Thickness
 - B-2.2. Cover/Cap Pipe Ends
 - B-2.3. Coating Thickness
 - B-2.4. Lining of Fittings and Specials
 - B-2.5. Field Application of Lining
 - B-2.6. Field Application of Coating

- B-3. Pipe Joints and Ends
 - B-3.1. Bell and Spigot Joint with Rubber Gasket
 - B-3.2. Lap Welded Joint
 - B-3.3. Butt Strap Joint
 - B-3.4. Flanged Joint

- B-4. Fittings and Specials

C. WORKMANSHIP

- C-1. Preparation of Trenches
 - C-1.1. Grade
 - C-1.2. Bell (Joint) Holes
 - C-1.3. Removal of Water

- C-2. Laying
 - C-2.1. Distributing Pipe
 - C-2.2. Handling Material
 - C-2.3. Cleaning Pipe and Fittings
 - C-2.4. Placing of Pipe in the Trench
 - C-2.5. Number of Pipe Laid Before Jointing
 - C-2.5.1. Push-on Joint Pipe
 - C-2.6. Preventing Trench Water from Entering Pipe
 - C-2.7. Bell End to face Direction of Laying
 - C-2.8. Permissible Deflection at Joints
 - C-2.9. Alignment
 - C-2.10. Unsuitable Conditions for Laying Pipe

- C-3. Jointing of Pipe
 - C-3.1. Jointing Push on Joint Pipe
 - C-3.2. Jointing Flanged Pipe and Fittings and Fittings
 - C-3.3. Jointing Lap Welded Joints
 - C-3.4. Jointing Butt Strap Closure Joints

- C-4. Setting Valves, Fittings, and Couplings
 - C-4.1. General
 - C-4.2. Location of Valves
 - C-4.3. Valve Boxes

- C-5. Blank

- C-6. Anchorage
 - C-6.1. Thrust Blocking
- C-7. Flushing
- C-8. Sewer Crossings
- C-9. Hydrostatic Tests
 - C-9.1. Duration
 - C-9.2. Expelling Air
 - C-9.3. Procedure
 - C-9.4. Leakage
 - C-9.5. Correction of Excessive Leakage
 - C-9.6. Visible Leaks
- C-10. Installation of Poly Pigs

**STANDARD SPECIFICATIONS
FOR
STEEL PIPE AND FITTINGS,
AN ALTERNATE PIPE FOR TRANSMISSION MAINS 42-INCHES AND LARGER**

Reference herein is made to standards, tests, methods and specifications of research and technical organizations as follows:

ASTM American Society for Testing Materials
AWWA American Water Works Association
ANSI American National Standards Institute

Reference to ASTM, AWWA or ANSI mean, in all cases, the standard or specification of latest revision unless otherwise stated in the Detail specifications.

A. SCOPE: This standard specification covers the materials and workmanship for the installation of cement-mortar lined and coated steel pipe, specials and fittings, as an alternate to ductile iron pipe for transmission mains 42-inch (42") and larger.

B. MATERIALS

Item Standard Specification, Test or Method Designation

B-0. Steel Pipe - General AWWA C200, AWWA M11

B-1. Steel Pipe AWWA C200

B-2. Cement-Mortar Protective AWWA C205
 Lining and Coating for Steel
 Water Pipe

B-3. Pipe Joints or Ends AWWA C200, AWWA M11

 Steel Pipe Flanges for Water AWWA C207
 Works Services

 Field Welding of Steel Pipe AWWA C206

B-4. Dimensions for Fabricated AWWA C208
 Steel Water Pipe Fittings

B-0. Steel Pipe - General

B-0.1. Application: The Cement-mortar lined and coated steel pipe, specials and fittings are only allowed as an alternate to ductile iron pipe for transmission mains of 42-inch (42") or larger.

B-0.2. Specials and Fittings Definition: A piece of pipe other than a normal full length of straight pipe. This includes, but is not limited to, elbows, short

pieces, reducers, tees, crosses, spools, sections with outlets, beveled sections and manholes.

- B.0.3. Pipe Manufacturing Operations (pipe, fittings, lining, coating, and joints): Performed at one (1) location unless otherwise approved. Provide the MWC with an affidavit, signed by a Professional Engineer registered in the state of the source manufacturing facility, stating that the source manufacturing facility has produced steel pipe of the specified diameters, dimensions, and standards for a period of not less than ten (10) years.
- B.0.4. Inspection and Testing of Pipe: Performed at the place of manufacture in accordance with the provisions of AWWA C200 and AWWA C205. Use the minimum hydrostatic test pressure specified in AWWA C200. Provide the MWC with at least 48 hours advance notice of the tests. The MWC may, at its option, witness any and all aspects of the manufacture and testing of the pipe, specials and fittings. Include all costs associated with the performance of the tests and the MWC witnessing of the pipe manufacturing and testing, including travel and accommodations.
- B.0.5. Environmental Regulations: Provide an Affidavit with each pipe shipment, signed by a Professional Engineer registered in the state of the source manufacturing facility, stating that all federal (United States), OSHA, EEO and environmental requirements, including Clean Air and Clean Water Acts, were met during the course of pipe production.
- B.0.6. ISO 9110 and 9002 Certification: Provide an affidavit, signed by a Professional Engineer registered in the state of the source manufacturing facility, stating that all steel pipe manufacturing facilities are certified.
- B.0.7. NSF/ANSI 61 Compliance: Provide certification, signed by a Professional Engineer registered in the state of the source manufacturing facility, that the products manufactured in the source facility have ten-year compliance with ANSI/NSF 61, Drinking Water System Components-Health Effects.
- B.0.8. Buy American: Provide a certification, signed by a Professional Engineer registered in the state of the source manufacturing facility, that all pipe shipped complies with the provisions of the Buy American Act as contained in the Supplemental Provisions of the specifications of the Bureau of Reclamation as noted on the website:
[http://contacts.gsa.gov/webforms.nsf/0/62F041FDE530311D85256AA2004BD02E/\\$file/gS1735.pdf](http://contacts.gsa.gov/webforms.nsf/0/62F041FDE530311D85256AA2004BD02E/$file/gS1735.pdf)
- B.0.9 Diameter of Pipe Definition: The net inside diameter of the mortar lining.
- B.0.10. Permeation: Contact the Engineering Division if contaminated soil is encountered to obtain instruction on possible pipe joint modifications.
- B.0.11. Submittal of Drawings and Calculations: Submit two sets of the manufacturer's certified line and layout drawings, fabrication drawings and calculations covering the design, manufacture, and fabrication of

steel pipe, fittings, specials and joint details to the Engineering Division for approval prior to the start of the fabrication of the pipe.

- B.0.12. Line and Layout Drawings: Comprised of detailed engineered layout sheets showing pipeline stations along the alignment of the steel pipe, vertical and horizontal angle points, location of all pipe mark numbers, pipe joints, fittings, specials, valves, appurtenances, thrust restraints, etc., the order of assembly of the various pieces during construction, tie-in locations and any other information required by the Engineering Division to determine complete compliance with these specifications.
- B.0.13. Fabrication Drawings: Include all spool pieces, spacers, adapters, connectors, fittings, joint details, etc. and indicate the type, thickness and grade of steel used, specific coatings and linings, including thicknesses, standard and special connection details, and any other information as required by the Engineering Division to determine complete compliance with these specifications.
- B.0.14. Calculations: Calculations supporting the sizing of reinforcing collar plates, wrapper plates or crotch plates, selected wall thickness of pipe and specials, welded joint design and joint welding details.
- B.0.15. Test Results: Submit the results of all testing required by AWWA C200 to the Engineering Division and obtain approval thereof prior to proceeding with fabrication.
- B.0.16. Affidavit of Compliance: Provide the Engineering Division with an Affidavit of Compliance, signed by a Professional Engineer registered in the state of the source manufacturing facility, with all applicable provisions of AWWA C200.
- B.0.17. Furnish, Install and Test Corrosion Control System: Furnish all labor, equipment and materials to study, design, install and test an Engineering Division approved corrosion control system for the protection of water mains and appurtenances. Employ the services of a Corrosion Specialist, accredited by NACE International, and approved by the Engineering Division, having proven expertise in designing, installing and testing or supervising the installation and testing of the approved corrosion control system.

Corrosion Control Survey and Design: As a minimum address the following:

- (a) Conduct an engineering study to determine the cause or causes of probable future corrosion problems and the type and extent of the required control system.
- (b) Determine the applicability of various corrosion control methods to provide adequate protection against corrosion. Recommend a system consisting of one or more methods of corrosion control, such as electrical isolation of vulnerable elements of the

installation, properly selected coatings, and cathodic protection. Where anodes are recommended, design to last and provide the required protection for at least twenty (20) years. Recommend the number and location of proposed corrosion control test stations required.

- (c) Analyze the effects of the proposed corrosion control system upon neighboring underground pipelines, utilities and other installations. Design the system to avoid any harm or damage to the said installations due to the installation and function of the corrosion control system.
- (d) Submit design documents to the Engineering Division for approval. Include the overall layout of the piping and appurtenances to be protected and the location of structure hardware, corrosion control test stations, electrical bonds, insulators, and neighboring buried or submerged metallic structures. Include the locations of anode installations on the drawings and in tabular form with appropriate notes as to anode type, weight, spacing, depth, and backfill.
- (e) Provide specifications for all materials and installation methods incorporated in the construction of the corrosion protection system.
- (f) Install the corrosion control system in strict conformance with the requirements shown on the approved design drawings and specifications. Perform all work in connection with the installation of the corrosion control system under the surveillance and direct supervision of the Corrosion Control Specialist. Note any deviations from construction specifications on as-built drawings.
- (g) After the corrosion control system is energized, conduct a survey by electrical measurements and inspections to determine that protection has been established in accordance with applicable criteria and that each part of the system is operating properly and efficiently.
- (h) Submit five (5) copies of an Operation and Maintenance Manual to the Engineering Division. As a minimum, include following information:
 - (1) Frequency and conduct of periodic surveys.
 - (2) Inspection test methods, testing equipment and instruments to be used.
 - (3) Remedial measures to be taken when periodic surveys and inspections indicate that protection is no longer adequate.

- (4) Corrosion control records to be established and maintained.

B-1. Steel Pipe

- B-1.1. Diameter and Quantity of Pipe: Provide cement-mortar lined and coated steel pipe in conformance with AWWA C200 in the sizes and quantities specified on the Approved Plans.
- B-1.2. Internal Design Pressure: Contact the Engineering Division to obtain the internal design pressure (verify that the design pressure includes transient loads such as surge or water-hammer pressures).
- B-1.3. Hoop Tensile Design Stress: Not to exceed 50 percent (50%) of the minimum yield strength of the steel when internal pressure is equal to design pressure (including working pressure and transient loads such as surge or water-hammer pressures).
- B-1.4. Steel Minimum Yield Strength: 42,000 psi for steel pipe.
- B-1.5. Minimum Steel Wall Thickness: 0.3125 inches for 42-inch (42") diameter pipe; 0.3750 for 48-inch (48") diameter pipe.
- B-1.6. Steel Cylinder – Coils: AWWA C200, continuous cast process, fully-killed, fine grained practice conforming to physical, manufacturing, and testing requirements of ASTM A1018/A1018M, SS, Grade 40.
- B-1.7. Pipe Lengths: A minimum of 40 feet (40') with special lengths, field trim pieces and closure pieces as required by plan and profile for location of elbows, tees, reducers and other in-line fittings.
- B-1.8. Marking Pipe: Plainly mark each length of straight pipe and each special at the bell end to identify the proper location of the pipe item by reference to the layout schedule. Identify the top of all pipe and specials by marking the top with "T.O.P." for easy identification in the field.
- B-1.9. Shipping and Handling: Install temporary internal bracing in all pipe prior to shipment to the job site. Install four-inch by four-inch (4"x4") wooden struts as temporary internal bracing in both the horizontal and vertical directions. Nail each set of struts together as a unit. Use wooden wedges to maintain the proper tight fit of the internal bracing. Locate the bracing 12 inches (12") in from each end of the pipe section for all pipe, and at spacing along the pipe to maintain roundness of plus or minus one percent (+/-1%) during shipping and handling. Ship coated pipe on bunks, and secure with nylon belt tied down straps or padded banding located approximately over braces. Maintain internal bracing as specified under Pipe Laying.

B-2. Cement-Mortar Protective Lining and Coating for Steel Water Pipe

- B-2.1. Lining Thickness: Cement mortar lining in accordance with AWWA C205 with a minimum thickness of one-half-inch (1/2").
- B-2.2. Cover/Cap Pipe Ends: Cap the pipe ends, immediately after application of the lining, with a waterproof cover to prevent the escape of moisture from the interior of the pipe. After the mortar has attained sufficient set, add water inside the pipe in a manner that will not damage the lining surface if required to maintain a moist condition. Keep the waterproof covers on the pipe throughout and beyond the curing period until immediately prior to the installation of the pipe. Replace any cover removed for the pipe coating operation as soon as practicable after the application of the coating.
- B-2.3. Coating Thickness: Cement mortar coating in accordance with AWWA C205 with a minimum thickness of three-quarters-inch (3/4"). Apply coating pneumatically or by impaction resulting in a dense uniform coating that adheres tightly to the pipe.
- B-2.4. Linings of Fittings and Specials: Apply cement-mortar lining to miters, angles, bends, reducers, and other special sections, the shape of which precludes application by the spinning process, by mechanical placement, pneumatic placement, or hand application and finish to produce a smooth, dense surface. Apply wire-fabric reinforcement or ribbon-mesh reinforcement to the interior of fittings at frequent intervals by tack welding to the pipe, by clips, or by wire. Place the wires on 2-inch (2") spacing on the two-inch by four-inch (2"x4") fabric and extend circumferentially around the fitting. Repaired areas of machine-applied linings at miters, pipe ends, outlets, and other cuts made in the lining for fabrication of the fitting need not be reinforced if the width of the repair area does not exceed 12 inches (12"). Apply a bonding agent to the steel and adjacent faces of the lining for repairs with widths exceeding 6 inches (6"). Provide the same thickness as required for spun lining of straight sections, except where feathering or filleting to a smooth transition with adjoining sections of pipe.
- B-2.5. Field Application of Lining: Fill inside joints of mortar-lined pipe with cement mortar and finish off smooth and flush with the inside surface of the pipe by troweling or by equivalent means. Before placing the joint mortar material against the surfaces of the lining, carefully clean the surfaces, have all soap removed, and then wet to ensure a good bond between the lining and the joint mortar. Do not put the pipeline into service until the mortar has cured for a minimum of 24 hours.
- B-2.6. Field Application of Coating: Coat the joint exterior by placing a heavy duty diaper over the joint. Span the entire uncoated area of the joint with the diaper except for an opening at the top for the placement of the grout. Secure the diaper with steel strapping. Pour the grout in one side of the diaper only, using a rod proceed until the entire joint recess is filled. Use a mixture of one-and-one-half to two (1½ - 2) parts sand to one (1) part Type II or Type V Portland Cement with enough clean, potable water to permit packing and troweling without crumbling. Use washed and well-

graded sand such that all will pass a No. 8 sieve. Use the minimum required quantity of water in the preparation of grout to produce a mixture sufficiently workable for the purpose intended. Achieve a grout minimum compressive strength of 1,800 psi in 28 days.

B-3. Pipe Joints or Ends

B-3.1 Bell and Spigot Joint with Rubber Gasket: Conform to AWWA C200 and as shown in AWWA M11, and either be rolled-groove or Carnegie-shape. The joint shall be suitable for the pressures of the class of pipe on which it is furnished, and shall operate satisfactorily with a deflection, the tangent of which is not to exceed 0.75 inch/D where D is the outside diameter of the pipe in inches, or with a uniform pull-out of $\frac{3}{4}$ -inch ($\frac{3}{4}$ ").

B-3.2 Lap Welded Joint: Conform to AWWA C200 and as shown in AWWA M11, use where restrained joints are indicated on the plans. Form the bell end integrally with the steel cylinder, swedged out by the machine circular in shape and designed and fabricated to withstand design pressure of the class of pipe specified and to permit the spigot end (plain end) to enter the belled end with a minimum lap of approximately one inch (1") with a clearance of approximately 1/32-inch (1/32"). Hold back shop applied lining and coating sufficiently to allow for welding of the joint.

B-3.3 Butt Strap Joint: Conform to AWWA C200 and as shown in AWWA M11 and on the approved plans. Install where shown on the approved plans in accordance with AWWA C206. Field weld to the outside plain end of the pipe along both edges with a full circumferential weld, using a minimum of two weld passes.

B-3.4 Flanged Joint: Conform to AWWA C200 and AWWA C207 Class E. Install flanges where indicated on the approved plans. Straddle bolt holes on the vertical centerline. Thoroughly clean the bolts, nuts and flange faces by wire brush prior to assembly. Lubricate bolts and nuts with an Engineering Division approved anti-seize compound. Tighten nuts in an alternating "star" pattern to the manufacturer's recommended torque. Install shop lining and coating continuous to ends of pipe and backs of flanges. Furnish gaskets in accordance with AWWA C207. Provide bolts in conformance to ASTM A193, Grade B7, and nuts to ASTM A194, Grade 2H. Zinc plate bolts and nuts in accordance with ASTM B633.

B-4. Fittings and Specials: Fabricate all fittings from individual sections of pipe, welded together, with the lining and coating of joints hand-applied comparable to mechanically-applied lining and coating detailed herein. Fabricate fittings in the shop unless otherwise approved by the Engineering Division. Fabricate fittings in accordance with AWWA C200 Section 4 from pipe conforming to the above standards. Fittings fabricated from previously hydrostatically tested straight pipe shall require testing of only those welded seams that were not previously hydrostatically tested in the straight pipe. This testing shall be by the dye penetrant examination per ASTM E 165 or magnetic particle examination in accordance with ASTM E 709. Conform fittings to the dimensions of AWWA

C208. Elbows shall have a minimum radius of 2½ times the pipe O.D. All tees, laterals and outlets shall be reinforced in accordance with AWWA M11.

C. WORKMANSHIP

C-1. Preparation of Trenches

C-1.1. Grade: The bottom of the trench shall be excavated to the line and grade to which the pipe is to be laid, with proper allowance for pipe thickness and for gravel bedding as specified. The trench bottom shall form a continuous and uniform bearing and support for the pipe on bedding material at every point between bell holes, except that for a maximum distance of 18 inches (18") near the center of the pipe, the bedding may be disturbed for the removal of lifting tackle. Where the trench is excavated in rock it is especially important that a minimum of three inches (3") of bedding material be used to obtain uniform bearing and support for the pipe.

C-1.2. Bell (Joint) Holes: At the location of each joint, bell (joint) holes of ample dimensions shall be dug in the bedding as necessary to permit the joint to be made properly and to permit easy visual inspection of the entire joint.

C-1.3. Removal of Water: The contractor shall at all times provide and maintain ample means and devices to remove and dispose of all water entering the trench excavation during the process of laying the pipe.

C-2. Laying

C-2.1. Distributing Pipe: Material shall be distributed on the job no faster than can be used to good advantage. In general, no more than one week's supply of material shall be distributed in advance of the laying

C-2.2. Handling Material: Store coated pipe on padded skids, sand or dirt berms, sand bags, old tires or other suitable means so that coating will not be damaged. Handle coated pipe with the wide belt slings, padded forks, or other means that will not damage the pipe. Do not use chains, cables or other equipment likely to cause damage to the pipe or coating. Visually inspect the pipe prior to shipment for damage to the coating. Repair any damaged areas in accordance with the standard to which the coating was applied.

Leave temporary internal pipe bracing in place until pipe zone compaction has have been completed. Employ a laboratory to monitor pipe deflection by measuring pipe inside diameter before bracing is removed and 24 hours after struts are removed. Pipe deflection shall not exceed 1 percent (1%) in 24 hours after the bracing has been removed. Remove the struts after the backfill is placed.

Proper implements, tools and facilities satisfactory to the Engineering Division shall be provided and used by the contractor for the safe and

convenient prosecution of the work. All pipe, fittings, valves, and hydrants shall be carefully lowered into the trench, piece by piece, by means of a crane or other suitable equipment, in such a manner as to prevent damage to the pipeline materials and protective coatings and linings. Under no circumstances shall pipeline materials be dropped or dumped into the trench.

- C-2.3. Cleaning Pipe and Fittings: All lumps, blisters and excess coating shall be removed from the bell and spigot ends of each pipe. The outside of the spigot and the inside of the bell shall be wiped clean and dry and free from dirt, grease and foreign matter before the pipe is laid.
- C-2.4. Placing of Pipe in the Trench: Every precaution shall be taken to prevent foreign material from entering the pipe while it is being placed in the line. If the pipe laying crew cannot put the pipe into the trench and in place without getting earth into it, the Engineering Division may require that, before lowering the pipe into the trench, a heavy, tightly woven canvas bag of suitable size shall be placed over each end and left there until the connection is to be made to the adjacent pipe. During the laying operations, no debris, tools, clothing or other materials shall be placed in the pipe.
- C-2.5. Number of Pipes Laid Before Jointing
 - C-2.5.1. Push-On Joint Pipe: Push-on joint pipe shall be connected as hereinafter specified as soon as they are placed in the trench.
- C-2.6. Preventing Trench Water from Entering Pipe: At times when pipe laying is not in progress, the open ends of pipe shall be closed by a water-tight plug or other means approved by the Engineering Division, and no trench water shall be permitted to enter the pipe. These provisions shall apply during the noon hour as well as overnight. If water is in the trench, the seal shall remain in place until the trench is pumped completely dry.
- C-2.7. Bell End to Face Direction of Laying: Unless otherwise directed, pipe shall be laid with bell end facing in the direction of the laying; and for lines on an appreciable slope, bells shall (at the direction of the Engineering Division) face upgrade.
- C-2.8. Permissible Deflection at Joints: Wherever it is necessary to deflect pipe from a straight line, either in the vertical or horizontal plane, to avoid obstructions or plumb stems or where long-radius curves are permitted, the amount of deflection allowed shall not exceed that approved by the Engineering Division.
- C-2.9. Alignment: Pipe lines intended to be straight shall be so laid, and in no case shall a deviation from the straight line at any joint exceed one inch (1").

C-2.10. Unsuitable Conditions for Laying Pipe: No pipe shall be laid in water or when in the opinion of the Engineering Division, trench conditions are unsuitable.

C-3. Jointing of Pipe

C-3.1. Jointing Push-on Joint Pipe: Steel pipe with push-on type joints shall be laid and jointed in strict accordance with the manufacturer's recommendations as approved by the Engineering Division and in accordance with the requirements of the Detail Specifications. The contractor shall provide all special tools and devices such as special jacks, chokers, and similar items required for the installation. Lubricant for the pipe gaskets shall be furnished by the pipe manufacturer, and no substitutes will be permitted under any circumstances.

C-3.2. Jointing Flanged Pipe & Fittings: Install flanged connections where indicated on the Approved Plans. Assemble flanged joints in accordance with AWWA M11. Execute care when tightening joints to prevent undue strain upon valves, pumps and other equipment. If flanges leak under pressure testing, loosen or remove the nuts and bolts, reset or replace the gasket, reinstall or retighten the bolts and nuts, and retest the joints. Joints shall be watertight. Bolt holes shall straddle the vertical centerline. Thoroughly clean the bolts, nuts and flange faces by wire brush prior to assembly. Bolts and nuts shall be lubricated with an approved anti-seize compound. Nuts shall be tightened in an alternating "star" pattern to the manufacturer's recommended torque. Slip-on type flanges intended for field fit-up and welding shall be welded inside and outside in accordance with AWWA C207.

C-3.3. Jointing Lap Welded Joints: Use where restrained joints are indicated on the plans. Wire brush exposed end of joint surfaces. Insert the plain end into the expanded bell such that the minimum overlap at any location around the joint circumference is in accordance with AWWA C206. Provide a single full fillet weld by certified welders qualified in accordance with AWS D1.1. Complete linings and coatings as specified in B-2.5 and B-2.6.

C-3.4. Jointing Butt Strap Closure Joints: Install where shown on the Approved Plans in accordance with AWWA C206. Field weld butt straps to the outside plain end of the pipe along both edges with a full circumferential weld. A minimum of two weld passes shall be used. Complete linings and coatings as specified in B-2.5 and B-2.6.

C-4. Setting Valves, Fittings and Couplings

C-4.1. General: Valves, fittings, plugs, couplings, and caps shall be set and jointed to pipe in the manner hereinbefore specified for cleaning, laying, and jointing pipe. All valves shall be operated through a full closed and full open position. Valves shall be checked for proper direction of operation.

C-4.2. Location of Valves: Valves in water mains shall, where possible, be located on the street property lines extended unless otherwise shown on the plans.

C-4.3. Valve Boxes: A valve box shall be provided for every valve. Valve box steel casing extensions shall be cut to proper length so that the valve box does not ride on the extension when set at finish grade and that the top section will slide over the extension for a minimum distance of 8 inches (8"). Valve casing shall be within eight inches (8") of finished grade. The valve box shall be centered and plumb over the valve wrench nut with the box cover flush with the finish surface. When valve boxes are set in paved streets, particular care shall be given to the placing of asphaltic concrete around the box to assure compaction of the paving materials under the shoulder of the box. When the distance from the top of the valve operating nut to the top of the valve box exceeds 36 inches (36"), an extension to the operating nut shall be furnished and installed by MWC at the developer's expense.

C-5. [Intentionally Left Blank]

C-6. Anchorage

C-6.1. Thrust Blocking: Reaction or thrust blocking shall consist of concrete of a mix not leaner than five sacks of cement per cubic yard of concrete and having a compressive strength of not less than 2,500 pounds per square inch. Thrust blocks shall not be backfilled for 12 hours unless authorized by Engineering Division. Blocking shall be placed between the undisturbed ground and the fittings to be anchored. Concrete blocking shall be formed with plywood and bear against solid undisturbed earth of the sides and bottom of the trench excavation. The quantity of concrete and the area of bearing for the pipe shall be as shown on the Plans or as directed by the Engineer. Drawing 109 in the Appendix shows the typical thrust block diagrams and the minimum bearing area. Caution must be exercised by the contractor to be sure the bearing capacity of the soil is at least 1500 psf before using the table. The blocking shall be so placed that, unless specifically shown otherwise on the plans, the pipe and fitting joints will be accessible to repairs. Eight (8.0) mil plastic shall be placed between all concrete and fitting or pipe.

C-7. Flushing: As soon as the pipe is laid, and before it is connected to the distribution system at more than one point, it shall be flushed through an open end of the pipe and at all blow-offs and fire hydrants. The contractor shall provide sufficient trench pumping capacity to pump out the water flushed from the open end and shall provide labor to assist MWC's representatives in flushing operations.

After the pipe has been completely laid and connected to the distribution system, and after testing and disinfection has been completed, a complete flushing through all dead-ends shall be done. The Contractor shall make all portions of the line, including dead-ends, accessible to MWC personnel and vehicles.

C-8. Sewer Crossings: Sewer crossings shall be as per current Oregon Health Division Public Water Systems/Oregon Administrative Rules, Chapter 333 unless modified by this section. In situations where a water line or service line and a sanitary sewer main or sewer lateral cross, the separation between the two shall be as follows:

- (a) Wherever possible, the bottom of the water line shall be 1.5 feet (1.5') or more above the top of the sewer line and one full length of the water line shall be centered at the crossing;
- (b) Where the water line crosses over the sewer line but with a clearance of less than 1.5 feet (1.5'), the sewer line shall be exposed to the sewer line joints on both sides of the crossing to permit examination of the sewer pipe. If the sewer pipe is in good condition, and there is no evidence of leakage from the sewer line, the 1.5-foot (1.5') separation may be reduced to 8 inches. The contractor must center one length of water line at the crossing. If the Engineering Division determines that the conditions are not favorable or finds evidence of leakage from the sewer line, the sewer line shall be replaced with a full length of pipe centered at the crossing point, of PVC pressure pipe (AWWA Standard C900), or ductile iron Class 50 (AWWA C51).
- (c) Where the water line crosses under the sewer line, the water supplier shall expose the sewer line and examine it as indicated in (b) of this section. If conditions are favorable and there is no evidence of leakage from the sewer line, the sewer line may be left in place, but must be supported with a reinforced concrete pier for preventing settlement when it spans the water line trench, and special precautions must be taken to assure that the backfill material over the water line in the vicinity of the crossing is thoroughly tamped in order to prevent settlement which could result in the leakage of sewage. In this situation, the contractor must center one length of the water line at the crossing. If MWC determines that conditions are not favorable or finds evidence of leakage from the sewer line, the provisions of (b) of this section apply.

Whenever a sanitary sewer is uncovered and the sewer pipe leaks or is broken, then ductile iron water pipe (not cast iron soil pipe) or PVC water pipe conforming to AWWA Standard C900 must be used to replace the sewer pipe. One full length of the ductile iron pipe or PVC pipe shall be centered at the water pipeline crossing so that the joints of both pipes shall be at least 9 feet (9') from the crossing centerline. Care must be taken to ensure smooth invert at the new sewer joints. The contractor shall make the repair at his own expense, including pipe trenching, backfill, and asphaltic pavement cutting and replacing necessary to install the 18-foot (18') length of ductile iron pipe or 20-foot (20') length of PVC pipe.

C-9. Hydrostatic Tests: NO TESTING OF WATER MAINS WILL BE DONE UNLESS THERE IS A MINIMUM OF 18 INCHES COVER OVER THE PIPE.

Pressure and leakage tests shall be made on all newly-laid pipe or any valved section of it, or both, unless otherwise specified in the Detail Specifications. MWC will conduct the tests, will furnish gauges for the tests, and will make all taps into the pipe. The contractor shall furnish all necessary assistance for conducting the test and he shall, if required, furnish the test pump, pipe connection, hoses, valves, and suitable graduated containers for measurement of the water used for testing.

The tests shall be conducted after the trench has been backfilled sufficiently to prevent movement of the pipe during testing and flushing. The joints may be left exposed for inspection. Where any section of pipe is provided with concrete reaction blocking, the pressure test shall not be made until at least five (5) days have elapsed after the concrete reaction blocking is installed. If high-early cement is used for the concrete thrust blocking, the time may be cut to two (2) days instead of five (5) days as previously specified.

The pressure test shall be conducted in the following manner. After the pipe has been backfilled or partially backfilled as hereinbefore specified, the pipe shall be filled with water. Unless stated otherwise in the Detail Specifications, the test pressure shall be 1½ times the normal static pressure, but not less than 150 pounds per square inch.

C-9.1. Duration: The duration of each pressure test shall be 60 minutes unless otherwise authorized by the Engineering Division.

C-9.2. Expelling Air: Before applying the specified test pressure, all air shall be expelled from the pipe.

C-9.3. Procedure: Each valved section of pipe shall be slowly filled with water to replace any lost; and the specified test pressure, measured at the point of lowest elevation, shall be applied by means of a pump connected to the pipe in a satisfactory manner.

The pump shall then be valved off, and the pressure shall be held in the line for the test period. At the end of the test period, the pump shall be operated until the test pressure is again attained. The pump suction shall be in a bucket, barrel, or similar device so that the amount of water required to restore the test pressure may be measured accurately.

C-9.4. Leakage: Leakage shall be defined as the quantity of water necessary to restore the specified test pressure at the end of the test period. No pipe installation will be accepted until the leakage is less than the number of gallons per hour as determined by the formula following:

$$L = \frac{ND (P)^{1/2}}{7400}$$

in which:

- L = allowable leakage in gallons per hour
- N = number of joints in the length of pipe tested

D = nominal diameter of pipe in inches

P = average test pressure during the leakage test in pounds per square inch.

C-9.5. Correction of Excessive Leakage: Should any test of pipe laid disclose leakage greater than that allowed under Item C-9.4. above, the contractor shall, at his own expense, locate and repair the defective joints or pipe until the leakage is within the specified allowance.

C-9.6. Visible Leaks: All visible leaks and known leaks revealed by the test shall be repaired regardless of the total amount of leakage shown by the test.

C-10. Installation of Poly Pigs: "Poly pigs" shall be supplied and installed by the contractor during installation of the pipeline. Number, sizes and locations shall be as determined by the Engineering Division. The "poly pigs" shall be moved through the pipeline system by the use of water pressure during flushing operations performed by MWC personnel, but after service taps have been made. All "poly pigs" shall be removed from the pipeline system by MWC prior to testing and disinfection. Used "poly pigs" become the property of MWC and their reuse determined by the inspector.

III

**STANDARD SPECIFICATIONS FOR
WATER SERVICES**

A. SCOPE..... 2

B. MATERIALS 2

B-1. Water Service Brass and Copper..... 2

B-2. Water Service Meter Box and Lids..... 2

B-3. Water Service Line Parts Procurement 3

C. WORKMANSHIP 4

C-1. Preparation of Trench & Backfill..... 4

C-2. Service Line Taps and Corporation Stop Installation..... 5

C-3. Copper Tubing Installation 6

C-4. Meter Set Installation 6

C-5. Service Line and Brass fitting Installation..... 7

C-6. Approved Tapping Equipment..... 7

C-7. Flushing Service Lines..... 7

C-8. Testing & Inspection of Services 7

C-9. Approved Service line Bedding and Cover 8

III

STANDARD SPECIFICATIONS FOR WATER SERVICES

Reference herein is made to standards, tests, methods and specifications of research and technical organizations as follows:

ASTM	American Society for Testing Materials
AWWA	American Water Works Association
ANSI	American National Standards Institute

A. SCOPE

This standard specification shall cover the approved materials and acceptable workmanship for the tapping and installation of one-inch (1"), one and a half inch (1.5") and two-inch (2") service lines.

B. MATERIALS

Only MWC approved materials shall be used in the construction of service lines and meter settings. All material must be American made.

B-1. Water Service Brass and Copper

- B-1.1. All brass fittings shall be manufactured by Ford or Mueller only; all fittings must conform to low lead standard with not more than a weighted average of a quarter percent (0.25%) lead, AWWA C800-05, NSF 61 as applicable. "NL" shall be cast into the main body of the fitting.
- B-1.2. All brass fittings shall be made with approved grip ring type compression connections.
- B-1.3. All copper tubing must be Type K Soft "Domestic" made with minimum working pressure of 150 PSI and conform to NSF-61 and AWWA C-800-84. Additionally, it must be C12200 ninety-nine point nine percent (99.9%) Pure Copper and meet the ANNEX G Safe Drinking Water Act (third party certification) ASTM B88 Seamless Copper Water Tube Type.

B-2. Water Service Meter Box and Lids

- B-2.1. Meter boxes and lids shall be limited to those manufactured by Christy Concrete Products Inc. Meter box dimensions shall not vary from Approved Product list.
- B-2.2. Concrete boxes must be made of Reinforced Concrete meeting ASTM C857 WUC 3.6.
- B-2.3. Composite (Fibrelyte) boxes and lids manufactured by Christy Concrete Products, Inc. may be used in lieu of concrete but must meet ANSI/SCTE-77, Tier 8.

B-2.4. Meter boxes and lids are for pedestrian loads only unless specified otherwise on MWC approved and stamped engineered plans.

B-2.5. The MWC approved water meter boxes for five eighths by three quarter inch (5/8"x3/4") meter set requires the use of a **FORD ONLY** manufactured Angle Meter Valve B91-324W-NL 3/4" x 1" MTR VALVE - YOKE x FIP (WITH A HH-34) HANDLE due to specific lay length. No other hand valve will be accepted.

B-3. Water Service Line Parts Procurement

B-3.1. One inch (1") Dry Taps:

All water service materials shall be procured from your local supplier in accordance with the MWC approved parts list noted on Standard Detail No. 101-A2 and 101-B2. All parts shall be inspected by MWC Inspector prior to installation and again prior to any backfill being placed, no exceptions.

B-3.2. One inch (1") Wet Taps:

(a) All materials for one inch (1") wet taps concurrent with multiple dry taps, shall be procured from your local supplier in accordance with the MWC approved parts list noted on Standard Detail No. 101-A2 and 101-B2. All parts shall be inspected by MWC Inspector prior to installation. Contractor to schedule such taps with MWC Inspector a minimum of seventy-two (72) hours in advance.

(b) All materials for one inch (1") wet taps not concurrent with multiple dry taps will be provided by MWC. Contractor to schedule such taps with MWC Inspector a minimum of 72 hours in advance.

B-3.3. One and a half inch (1.5") and two-inch (2") taps:

All materials for one and a half inch (1.5") and two-inch (2") taps will be provided by MWC. Contractor to schedule such taps with MWC Inspector a minimum of seventy-two (72) hours in advance.

B-3.4. One inch (1") Service Line Approved Parts List:

(a) One-inch (1") Water Service and five eighths by three quarter inch (5/8"x3/4") Meter Set: See Detail 101-A2.

(b) One-inch (1") Water Service and one-inch (1") Meter Set: See Detail 101-B2.

C. WORKMANSHIP

C-1. Preparation of Trench & Backfill

C-1.1. Trenches shall be prepared in accordance with the applicable Standard Details in the 100-Series (100A, 100B, 100C and/or 100D) included in these specifications. Service Line Backfill shall consist of three (3) zones: Service Line Bedding, Service Line Cover and Finish Backfill. For approved bedding and cover Sand (Reject, Fill, Washed) sources see Section C-9.3.

C-1.2. Zones:

- (a) Zone 1 – BEDDING: Prior to adding bedding, care should be taken to ensure no rocks or foreign material are in the trench bottom that could cause damage to the copper tubing during installation and compaction. The Bedding Zone starts at the Native Excavated Trench Bottom and contains a minimum of four inches (4") of MWC approved Sand (Reject, Fill, Washed) below the entire length of the copper tubing. Bedding shall be placed prior to laying copper tubing in the trench.
- (b) Zone 2 – COVER: This zone is the protection area above copper tubing to ensure no damage to the copper tubing occurs during compaction and further construction. This zone is required by MWC before any other agency backfill is placed. This Zone shall consist of twelve inches (12") of MWC approved Sand (Reject, Fill, Washed) above entire length of the copper tubing.
- (c) Zone 3 – FINISH BACKFILL: The last layer of backfill placed above the Cover Zone and immediately below any concrete or asphalt structural section, as applicable. This Zone should consist of material specified by the governing agency and engineered plans.

In Rights-of-Way, approved Finish Backfill shall be installed and compacted in accordance with the specifications of the Right-of-Way Agency and stamped engineered plans.

Outside of Rights-of-Way and paved areas, refer to Governing Agency and stamped engineered plans. In NON-PAVED AREAS, unless otherwise directed by the Governing Agency or stamped engineered plans, Select Native Backfill is permitted. Select Native Backfill is specified as material on site that consists of native material including such material as sand, sandy loam, clay and rock not to exceed four inches (4") in diameter.

C-1.3. Care must be exercised in the bottom twelve inches (12") of the trench if mechanical compaction is used. Water jetting is the preferred method of compaction if it is allowed by the Governing Agency.

C-1.4. Parallel utilities to the water service shall have a minimum of five feet (5') of separation, centerline to centerline. Where the parallel utility is sewer,

separation shall be a minimum of ten feet (10'), centerline to centerline. Under no circumstance shall common trenches be allowed.

C-2 Service Line Taps and Corporation Stop Installation

C-2.1. Dry one inch (1") Taps:

One inch (1") taps made directly to new water line currently under construction (not yet active) for the purpose of installing an MWC approved corporation stop. This will be the starting point of a domestic or irrigation service line and act as a service line shut off for future service line repair. Dry taps may only be made by an MWC approved Prequalified Contractor.

C-2.2. One and a half inch (1.5") and two-inch (2") Taps:

These taps are made by MWC Service Crews ONLY, regardless of whether the line being tapped is dry or wet (active). Scope of contractor work is described in the MWC approved engineer stamped plans and/or the MWC issued Fee Letter. Since field conditions can vary, contact the MWC Inspector to discuss requirements at least seventy-two (72) hours prior to excavation. When MWC is performing all work including excavation and resurfacing, the contractor shall provide at least 1 week notice to allow for locates, permits, scheduling, etc.

C-2.3. Service Line Taps and Pipe Type: Service taps can be performed on various types of water lines, however the technique may vary:

(a) Ductile Iron and Cast Iron mains tapped for one-inch (1") corporation stops are normally directly tapped. If the threads are stripped during this process, a Ford FS1 Stainless Steel Circular Repair Clamp with a one-inch (1") CC Thread shall be used with outlet centered over stripped hole. If this repair method is to be used, the MWC Inspector must be present during installation of repair clamp. All one-inch (1") taps must be minimum of twelve inches (12") apart side to side. Taps made on opposing side of pipe shall be twelve inches (12") away from any opposing taps.

(b) All existing mains to be tapped when the system is under pressure (wet taps) shall be done by MWC Service Crews ONLY, no exceptions.

(c) Only approved tapping equipment as noted in Section C-6 shall be used. All equipment being used must be in good working order. All tapping bits must be in good condition and properly greased with potable water-approved grease. The tapping operation is a vital link in the installation of any service, and it must be in accordance with manufacturer's recommendations.

(d) The corporation stop shall be tapped at a forty-five-degree (45°) angle up from the spring line of water pipe as shown on Standard Details No. 101-A and 101-B. After the tapping operation, the corporation stop must

be further tightened by hand using only a smooth wrench and turned so that the operating keyway is pointed up.

C-3. Copper Tubing Installation

- C-3.1. The copper tube must be fully seated in the compression fitting. Clean factory or cut ends must be used when seating into all fittings. The compression coupler and gasket should slide over copper tubing freely. Copper tubing can become out of round by cutting or mishandling, causing the compression coupler and gasket to not fit over copper tubing. To ensure proper rounding of copper tubing, a crescent wrench may be used in a circular rotation. Doing this will allow the compression coupler and gasket to slide onto copper tubing without force. Tighten compression nut using a smooth wrench until it contacts the shoulder of compression fitting. No threads or gap should appear between corporation shoulder and the compression fitting. If either exist, it is not fully tight.
- C-3.2. All service lines must be laid perpendicular to the water line, unless otherwise shown on MWC approved stamped engineered plans. All bends must be smooth and even. Any crimped or out-of-round copper tubing must be removed. No joints are allowed in the copper tubing between corporation stops and the angle meter valve in service line runs that are less than one hundred feet (100').
- C-3.3. If construction around the copper tube breaks the service line, the entire length of copper from corporation stop to angle meter valve must be replaced. Couplers will not be accepted.

C-4. Meter Set Installation

- C-4.1. The correct finished grade and location of the meter setting are essential for proper clearance of water meters and radio read equipment (MXUs). This can only be accomplished through proper construction staking. The MWC inspector must see that the construction site is properly staked in accordance with MWC's Standard Detail No. 100 series.
- C-4.2. After the copper tube and angle meter valve are placed, the meter yoke and its appurtenances shall be installed. The yoke must be installed level and at a ninety-degree (90°) angle from the curb or sidewalk.
- C-4.3. The final operation of the meter setting shall be the installation of the meter box and lid. The box must be centered squarely over the yoke, installed level, and have ten inches (10") of clearance between the top of the angle meter valve and the top of the meter box lid. It is essential that the finished grade of the box be compatible with the finished grade of the right-of-way.
- C-4.4. After the project is completed, including all site grading, any meter setting which is not compatible with the finished grade will be required to be adjusted accordingly. Caution must be exercised when setting the service: any major adjustment of the box will require adjustment in the meter yoke, and meter valve.

C-5. Service Line and Brass fitting Installation

C-5.1. Read all manufacturer installation instructions and warranty carefully.

C-5.2. Brass fittings can be damaged by improper handling. Protect threads. Avoid loose fitting wrenches. Do not drop. Keep threads free from debris. Backfill and compact carefully so the fittings and tubing/pipe are not stressed by the weight of the earth. KEEP FROM FREEZING.

C-5.3. Approved wrenches must be used for service line and brass installation. **Do not use a pipe wrench or vise.** Only smooth service wrenches shall be used, no exceptions.

C-6. Approved Tapping Equipment

C-6.1. Tapping Machine:

(a) Muller – (B-100) or (B-101)

(b) Reed – (TM1100)

(c) Romac – (Tap Mate Drill Tap) – used with Rigid 690 Power Head

C-6.2. Power Head:

(a) Mueller H603 - Mounts directly to B-100/B-101

(b) Reed – (RD-05276) Pipe Tapping Power Drive with Adapter, 700PDTMPDA

(c) Rigid – (690)

C-7. Flushing Service Lines

C-7.1. All taps must be made prior to flushing the pipe pig. Flushing the pipe pig will remove all shavings as well as any other debris inside the new water main.

C-7.2. After the total service line is installed and the pig is flushed by the MWC Inspector all water main ends will be plugged. Once service lines and main lines have been properly bedded and compacted and all end caps and plugs installed, the MWC Inspector will fill and flush the main line and all service lines to ensure proper operation and to eliminate air and any debris. Contact MWC Inspector to schedule forty-eight (48) hours prior to all flushing.

C-8. Testing & Inspection of Services

C-8.1. Prior to any service line being covered with any backfill, it must be visually inspected by the MWC Inspector. The contractor may only bury the copper service line after the inspection, no exceptions.

C-8.2. After all services have been installed, the main and services will be required to conform to a hydrostatic test as defined under Section C-9 of the "Standard Specifications for Ductile Iron Pipe, Cast Iron Fittings, Valves, and Fire Hydrants, Specification IIA.

C-9. Approved Service line Bedding and Cover

C-9.1. MWC approved service line bedding and cover shall consist of only sand (Reject, Fill, Washed). No other material shall be used such as birdseye, pea-gravel, decomposed granite, buck-shot, concrete sand or any sands with recycled processed materials or angular rocks, etc.

C-9.2. No sand backfill shall contain any amount of crushed concrete with any mixture of asphalt or cement.

C-9.3. MWC approved Sources are noted in Table 1 below:

TABLE 1: MWC-APPROVED BEDDING AND BACKFILL SOURCES FOR ONE INCH (1") SERVICE LINES	
Company	Site
Hilton	Willow Creek
Rogue Aggregate (1)	Meridian (HWY 140)
Rogue Aggregate (2)	Advanced Aggregate
Rogue Aggregate (3)	Quality Rock
Rogue Aggregate (4)	Dry Creek
Rogue Aggregate (5)	High Banks
S. Oregon Rock	Young Hill Quarry
Robco Inc.	Richie Mountain
Crater Sand and Gravel	Savage Pit
Burl Brim	Roxy Ann
L&S Rock (1)	Stanley Pit
L&S Rock (2)	Anderson Butte Quarry
Southern Oregon Ready Mix	Venable Pit
Panther Crushing	Panther Quarry 1

IV

STANDARD SPECIFICATIONS FOR POLYETHYLENE ENCASEMENT (POLYWRAP)

A. SCOPE: This specification includes requirements for Polyethylene Encasement of ductile Iron water mains in accordance with ANSI/AWWA C105/A21.5-10 and ASTM D4976 and NT4112-10; and requirements for tapping polywrapped waterlines.

B. SPECIFICATIONS

- B-1. Tube-type polyethylene encasement (polywrap) shall be installed on all ductile iron pipe and fittings in accordance with AWWA Standard C105 - latest revision. Service connections shall be wrapped three feet (3') out from tap location towards meter.
- B-2. Polywrap shall conform to the requirements of ANSI/AWWA C105/A21.5 ASTM A674 and be Low-Density (LD) eight-millimeter (8 mil) thick tubing or four-millimeter (4 mil) thick high-density cross-laminated (HDCL) polyethylene. The tubing shall be marked with legible print denoting the conformance to ANSI/AWWA C105. Polywrap shall be rolls with perforated sections of twenty to twenty-two feet (20'-22') ensuring twelve inches (12") of overlap on each end of pipe. The tubing shall be installed in accordance with AWWA C600.
- B-3. When placing pipe in trench, care shall be used such that no damage is done to the polywrap. Any pipe lifting methods to place pipe in ditch such as lifting straps, clamps or chains shall not cause damage to polywrap. Lifting straps are highly recommended. Any damage to the polywrap shall be repaired using the approved PVC adhesive tape.
- B-4. All slack in the polywrap shall be folded and taped. Circumferential wraps of tape or plastic tie straps shall be placed at two-foot (2') intervals along the barrel of the pipe. All ends shall be overlapped twelve inches (12") and taped. Pre-excavated bell holes a minimum of twelve inches (12") around the water line are recommended for taping overlapped pipe ends. Prior to inspection and any backfill, all damage to polywrap shall be repaired using the approved PVC tape.
- B-5. The approved PVC tape used in conjunction with polywrap shall be two-inch ten-millimeter (2"-10mil) PVC film coated with a noncorrosive pressure sensitive adhesive printed with the UPC code and mil thickness designated.
- B-6. The polywrap shall prevent contact between the pipe and the surrounding backfill and bedding material but is not intended to be a completely airtight or watertight enclosure. All lumps of clay, mud, cinders, and so forth, on the pipe surface shall be removed prior to installation of the polywrap. During installation, care shall be exercised to prevent soil or embankment material from becoming trapped between the pipe and the polywrap.

- B-7. Refer to Ductile Iron Pipe Research Association (DIPRA) and Polywrap Manufacturer Recommendations for installation guides and tips.
- B-8. Medford Water Inspector must be contacted for inspection of polywrap encasement prior to any backfill placement.
- B-9. For correct polywrap encasement sizing, refer to Figure 1 below. For larger sizes, refer to the manufacturer.

FIGURE 1 - POLYWRAP SIZING CHART		
PIPE DIAMETER (in)	DIP WITH PUSH-ON JOINTS (in)	DIP WITH MECHANICAL JOINTS (in)
4	14	16
6	17	20
8	21	24
12	29	30
16	37	37
24	53	53

C. TAPPING POLYWRAPPED PIPE

- C-1. Three (3) layers of PVC adhesive tape shall be wrapped around any polywrapped pipe where a tapping machine will be placed. Excavating a minimum of twelve inches (12") all the way around waterline for installation of PVC tape layers is suggested.
- C-2. Direct tapping is permitted once the three (3) layers of PVC tape are installed. After the tapping process is complete, check tape and polywrap to ensure no damage occurred. If any damage is present, repair with approved PVC adhesive tape.
- C-3. All copper services connected to a polyethylene encased pipe including corp stop and copper service line shall be wrapped from tap location to three feet (3') out towards meter.
- C-4. Refer to Ductile Iron Pipe Research Association (DIPRA) and Polywrap Manufacturer Recommendations for installation guide and tips.
- C-5. Medford Water Inspector must be contacted for inspection of polywrap encasement prior to any backfill placement.

SECTION V

STANDARD

DETAIL

DRAWINGS

STANDARD DETAIL DRAWINGS

TABLE OF CONTENTS

100A	Meter Installation and Location (General)
100B	Single Family Service Installation (Medford)
100C	Water Facility Location (General)
100D	Water Facility Location (White City)
101-A1	1" Service with 5/8" x 3/4" Meter Setting
101-A2	1" Service with 5/8" x 3/4" Meter Setting Approved Materials
101-B1	1" Service with 1" Meter Setting
101-B2	1" Service with 1" Meter Setting Approved Materials
102	Sample and Disinfection Tree
103	Full Size Flush Point
104	Hydrant Installation for 14-Inch Main and Smaller
105	Hydrant Installation for 16-Inch Main and Larger
106	1-Inch Air Valve
107	2-Inch Air Valve
108	Mainline Blowoff Assembly
109	Thrust Blocks
110	Casing Detail
111	Typical Trench Detail
112	Bollard Detail
113	Support Pier Detail
114	Polyethylene Encasement (Polywrap) Detail

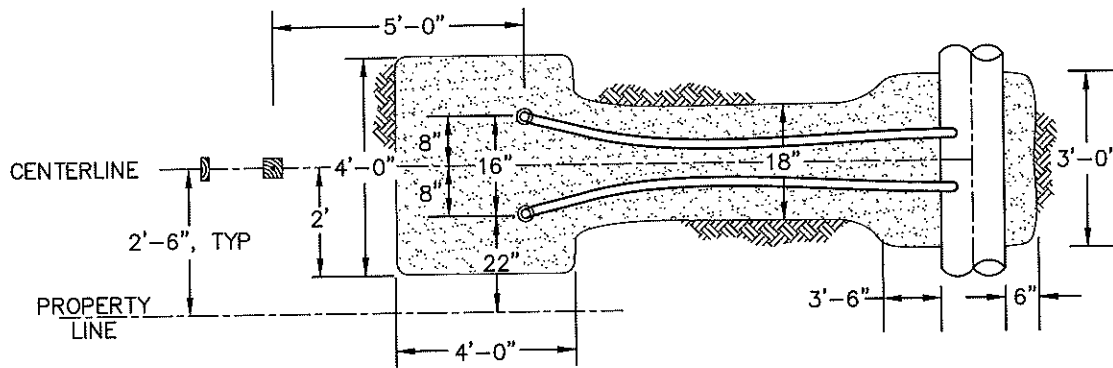

PLAN

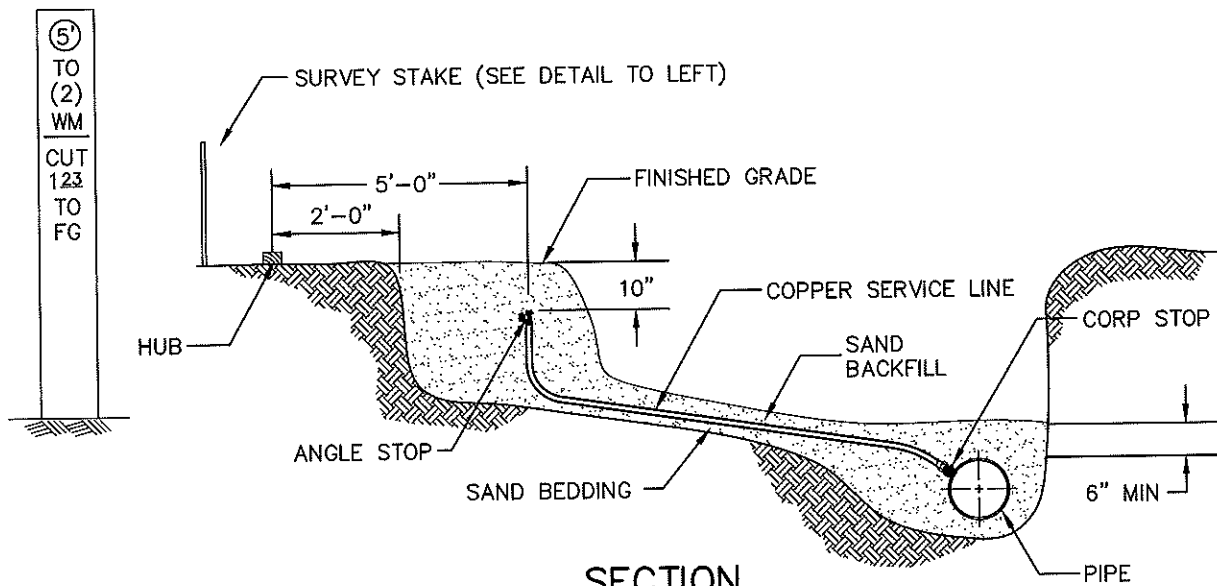

SECTION

NOTES:

1. DEPTH OF COVER SHALL BE 3 FEET AT MAIN AND 2 FEET AT METER PAD.
2. WATER METER STAKE INFORMATION SHALL INCLUDE 1) OFFSET DISTANCE, NUMBER OF SERVICE METERS, AND 3) CUT OR FILL TO FINISHED GRADE.
3. WATER METERS SHALL NOT BE LOCATED IN DRIVEWAYS.
4. WATER METERS SERVING LOTS ON A MINIMUM ACCESS EASEMENT (MAE) OR FLAG LOT SHALL BE GROUPED ON ONE SIDE OF THE DRIVEWAY WITHIN THE PUBLIC RIGHT-OF-WAY.

9/22/09 100A.dwg



REV	METER INSTALLATION AND LOCATION (GENERAL)
10/09	STANDARD DETAIL NO. 100A

ONE WATER SERVICE PER LOT, NO TEE'S OR VALVES ALLOWED BETWEEN WATER MAIN AND WATER METER.

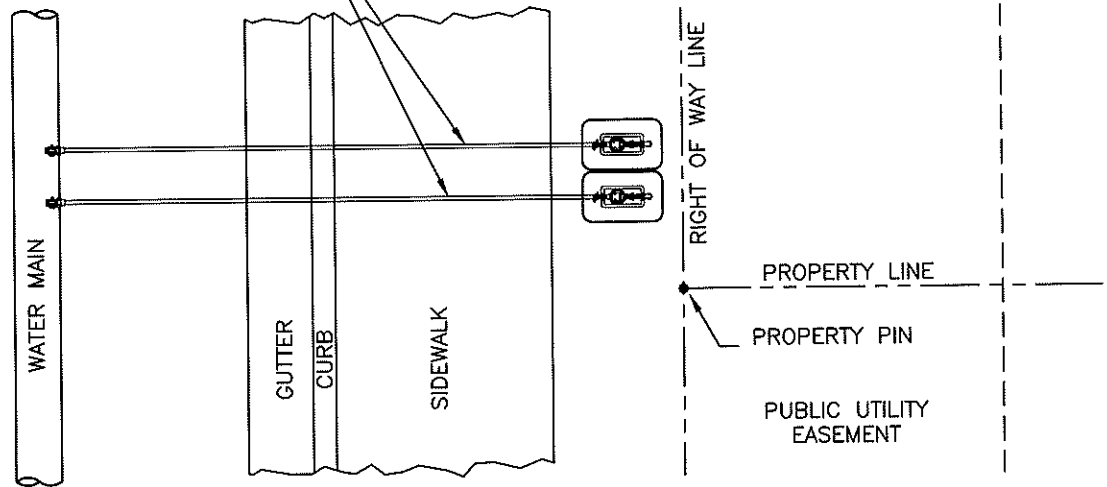

PLAN

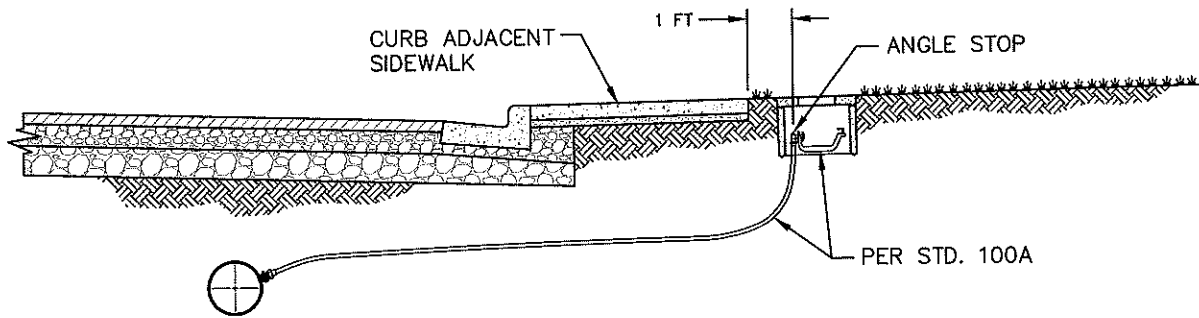

SIDEWALK ADJACENT TO CURB VIEW

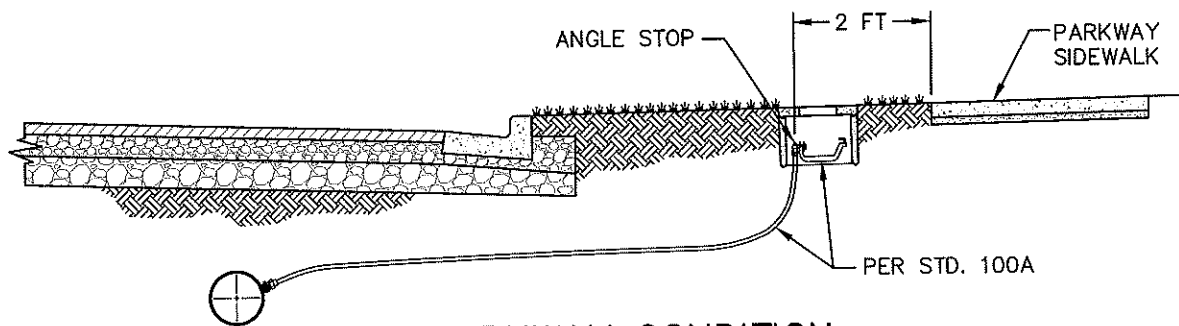

PARKWAY CONDITION

9/22/09 100B.dwg



REV	SINGLE FAMILY SERVICE INSTALLATION (MEDFORD)
10/09	STANDARD DETAIL NO. 100B

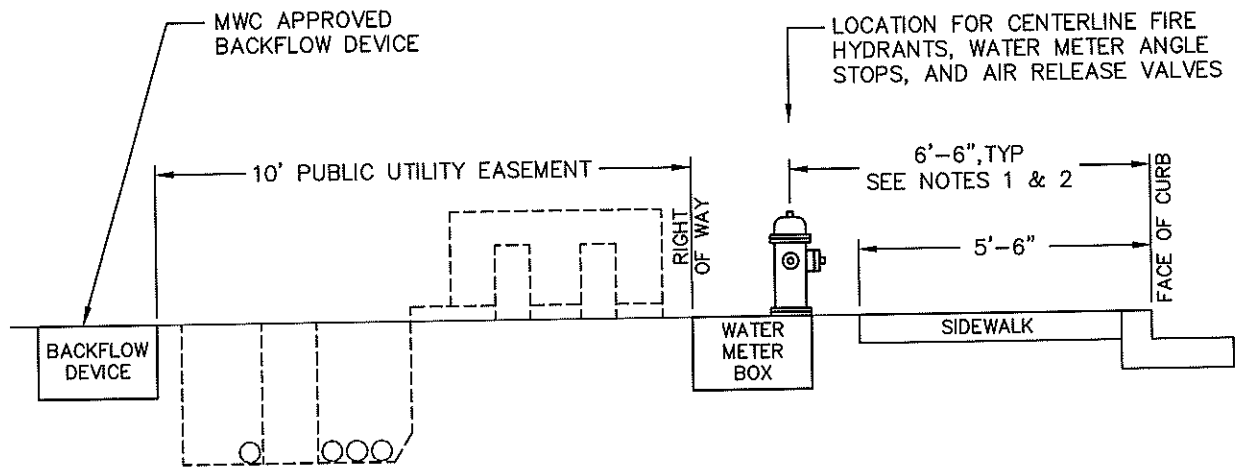

NOTES:

1. IF PARKWAY SITUATION, THEN LOCATE A MINIMUM OF 2' FROM FRONT EDGE OF SIDEWALK.
2. IF RIGHT-OF-WAY/STREET WIDTHS PRECLUDE FIRE HYDRANTS, WATER METERS, AND AIR RELEASE VALVES FROM BEING WITHIN RIGHT-OF-WAY, THEN DESIGN ENGINEER/SURVEYOR/DEVELOPER SHALL CONFIRM LOCATIONS WITH MWC.
3. WATER FACILITIES SHALL NOT BE LOCATED IN THE PUBLIC UTILITY EASEMENT (P.U.E.)
4. EASEMENTS REQUIRED FOR ALL WATER FACILITIES LOCATED OUTSIDE OF PUBLIC RIGHT-OF-WAY.
5. LOCATION OF WATER FACILITIES IN COMMERCIAL AND INDUSTRIAL AREAS SHALL BE COORDINATED AND APPROVED BY MWC ENGINEERING DEPARTMENT PRIOR TO INSTALLATION.
6. LOCATION OF WATER FACILITIES IN DOWNTOWN MEDFORD SHALL BE LOCATED 30" FROM FACE OF CURB.

9/22/09 100C.dwg



REV	WATER FACILITY LOCATION (GENERAL)
10/09	STANDARD DETAIL NO. 100C

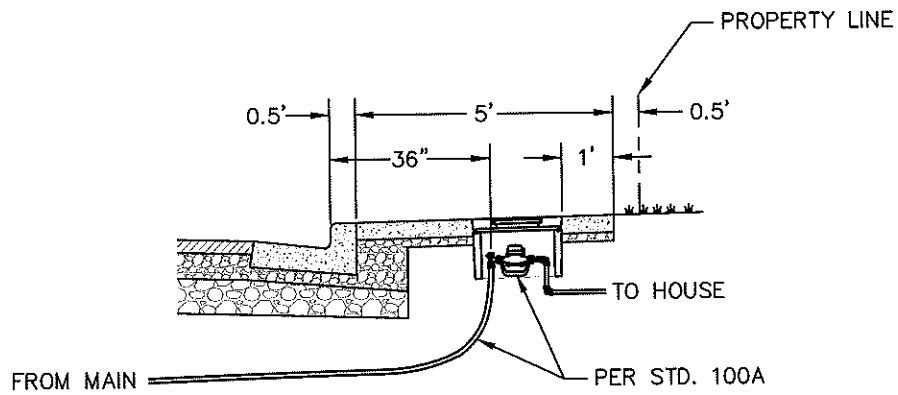

SINGLE FAMILY SERVICE INSTALLATION

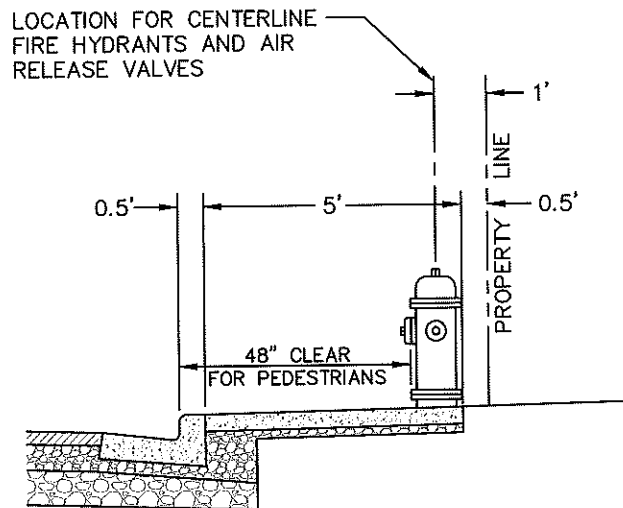

FIRE HYDRANT AND AIR RELEASE VALVE LOCATION

9/22/09 100D.dwg



REV	WATER FACILITY LOCATION (WHITE CITY)
10/09	STANDARD DETAIL NO. 100D

WATER SERVICE PROFILE VIEW

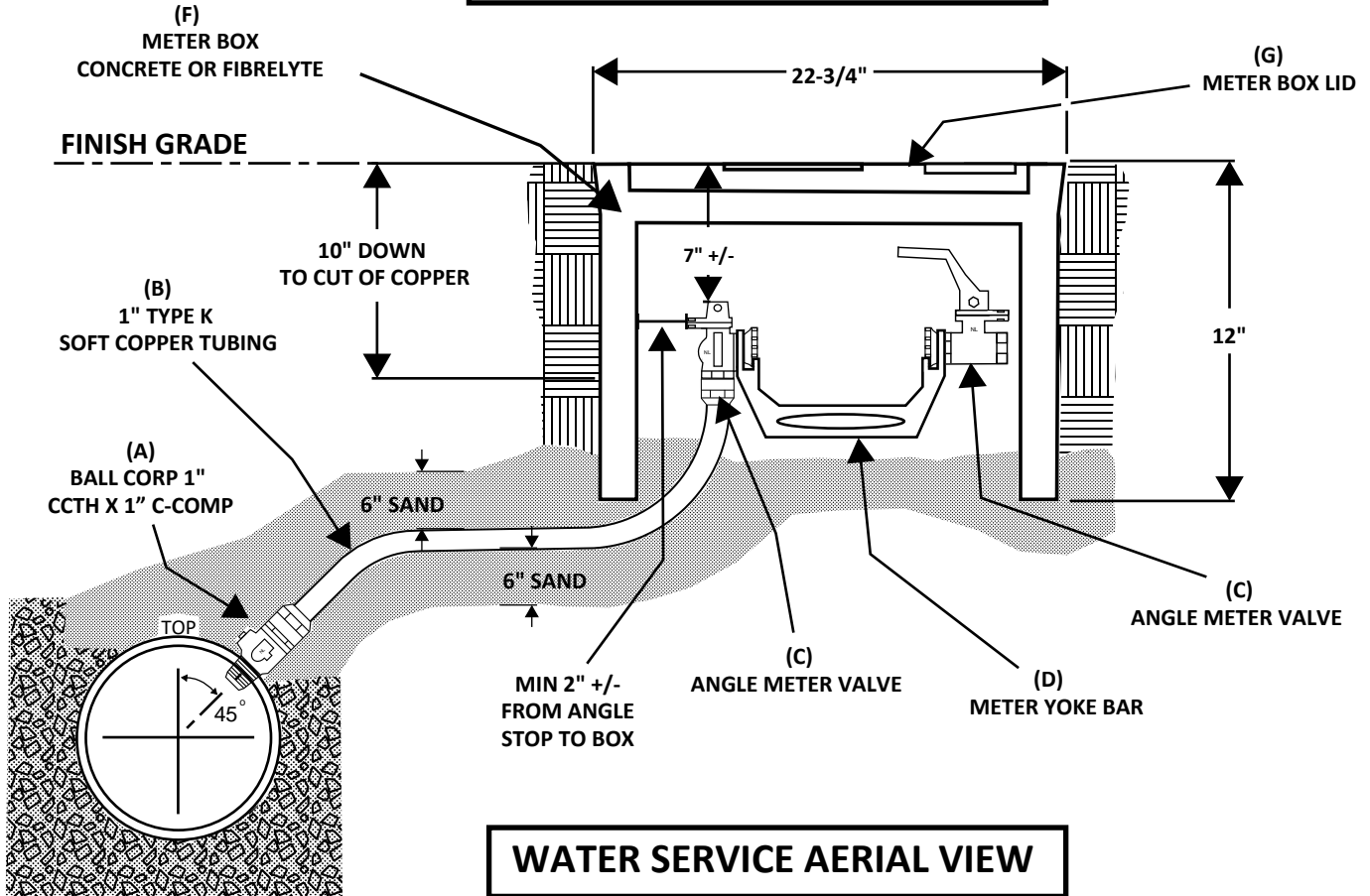

WATER SERVICE AERIAL VIEW

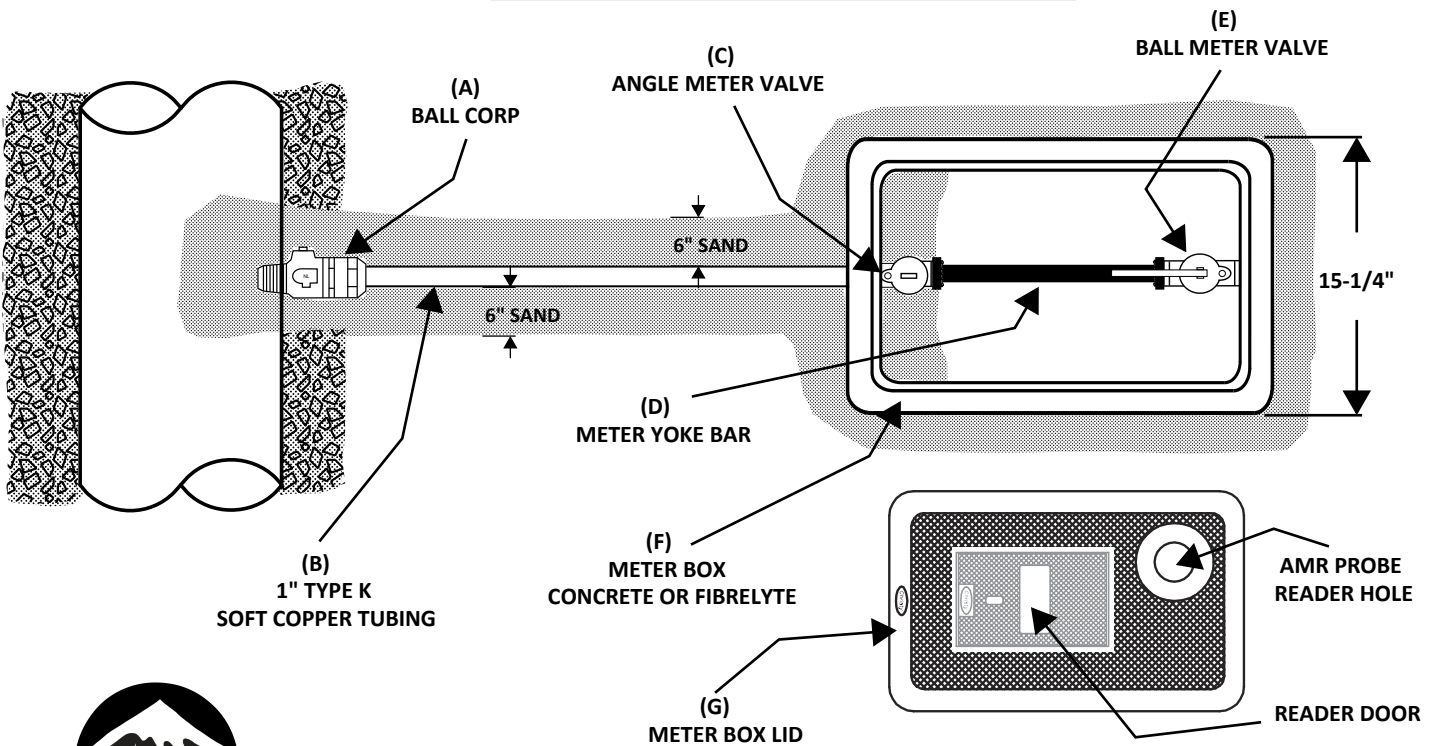

MEDFORD WATER

REV	1" WATER SERVICE WITH 5/8" x 3/4" METER SETTING
6/13/23	STANDARD DETAIL NO. 101-A1

MATERIAL LIST:

(A) BALL CORP - 1" CCTH X 1" C-COMP

Mueller: B-25008N

Ford: FB1000-4-Q-NL

(B) TYPE K SOFT COPPER TUBING - 1" (60'-100' rolls)

Cambridge: UNS No. C12200 ASTM B88

Cerro: UNS No. C12200 ASTM B88

Steam Line: UNS No. C12200 ASTM B88

(C) ANGLE METER VALVE - 5/8" x 3/4" x 1" C COMP x YOKE

Mueller: B-24273-3N

Ford: BA94-324-W-Q-NL

(D) METER YOKE BAR - 5/8" x 3/4" EPOXY COATED (L = 10-15/16" H = 3-31/32")

Mueller: H-5020 (epoxy coated only)

Ford: Y502 (epoxy coated only)

(E) BALL METER VALVE - 3/4" x 1" YOKE x FIP - W/HH-34 HANDLE

Ford Only: B91-324W-NL

(F) METER BOX FOR 5/8 x 3/4" METER SET and 1" METER SET

Christy: B12 - Concrete Box, Factory #1000050 Reinforced
Concrete with Composite Cap 23" x 15" 12"
Straight 0 - 2 ASTM C857, WUC 3.6

Christy: FL12 - Composite (Fibrelyte) 12" x 20" 12" Flared
ANSI/SCTE-77, Tier 8

(G) METER BOX LID

Christy: B12-GP "MWC" Reinforced Concrete Lid with 5" x 8" self
closing reader door and probe hole



MEDFORD WATER

REV	1" WATER SERVICE WITH 5/8" x 3/4" METER SETTING APPROVED MATERIALS
6/13/23	STANDARD DETAIL NO. 101-A2

WATER SERVICE PROFILE VIEW

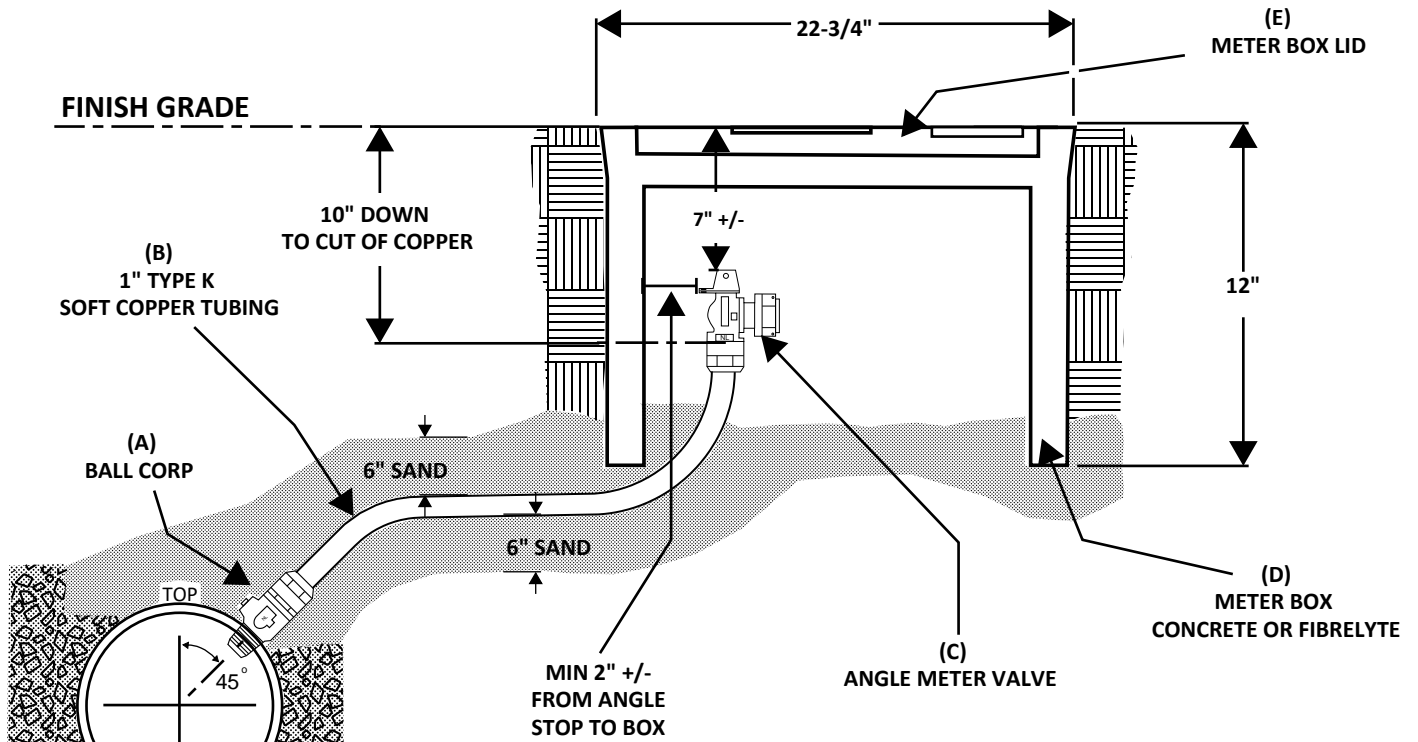

WATER SERVICE AERIAL VIEW

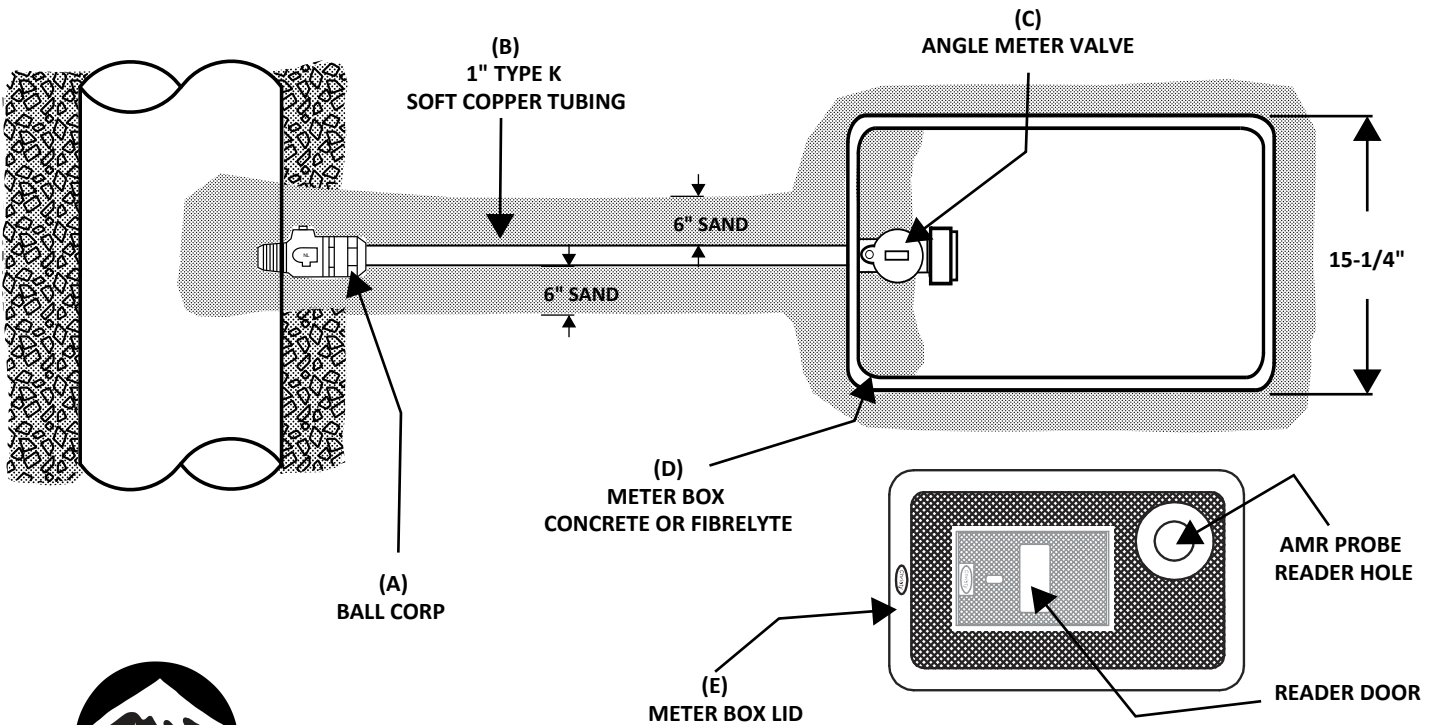

MEDFORD WATER

REV	1" WATER SERVICE WITH 1" METER SETTING
6/13/23	STANDARD DETAIL NO. 101-B1

MATERIAL LIST:

(A) BALL CORP - 1" CCTH X 1" C-COMP

Mueller: B-25008N

Ford: FB1000-4-Q-NL

(B) 1" TYPE K SOFT COPPER TUBING - (60'-100' rolls)

Cambridge: UNS No. C12200 ASTM B88

Cerro: UNS No. C12200 ASTM B88

Steam Line: UNS No. C12200 ASTM B88

(C) ANGLE METER VALVE - 1" ANGLE STOP, 1" C-COMP x 1" MTR-SNUT

Mueller: B-24258-3N

Ford: BA43-444WQ-NL

(D) METER BOX FOR 5/8 x 3/4" METER SET and 1" METER SET

Christy: B12 - Concrete Box, Factory #1000050 Reinforced
Concrete with Composite Cap 23" x 15" 12"
Straight 0 - 2 ASTM C857, WUC 3.6

Christy: FL12 - Composite (Fibrelyte) 12" x 20" 12" Flared
ANSI/SCTE-77, Tier 8

(E) METER BOX LID

Christy: B12-GP "MWC" Reinforced Concrete Lid with 5" x 8" self
closing reader door and probe hole



MEDFORD WATER

REV	1" WATER SERVICE WITH 1" METER SETTING APPROVED MATERIALS
6/13/23	STANDARD DETAIL NO. 101-B2

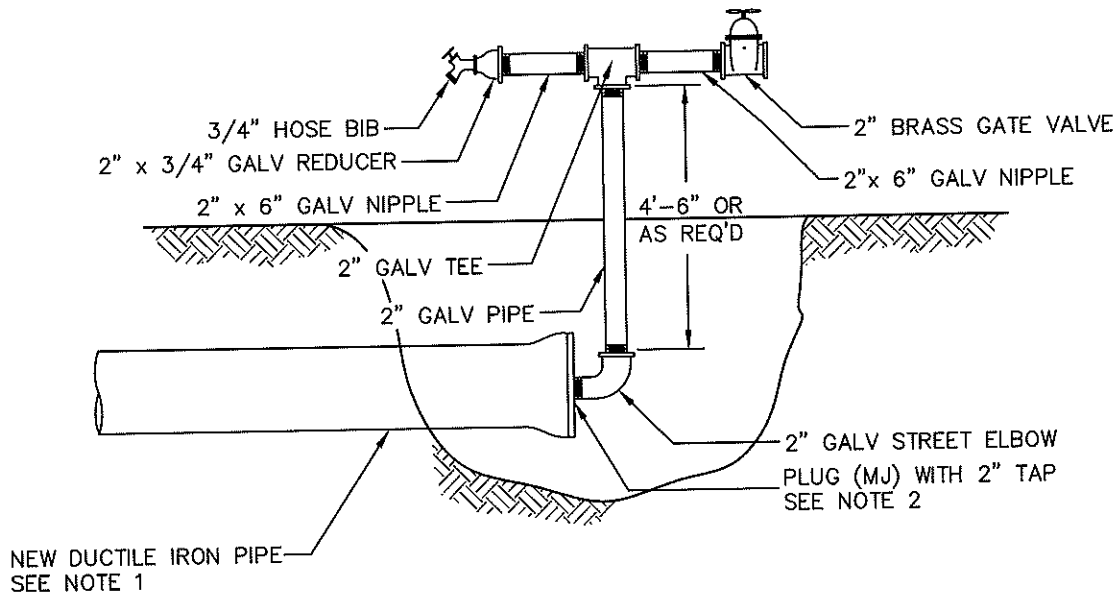

2" SAMPLE TREE

NTS

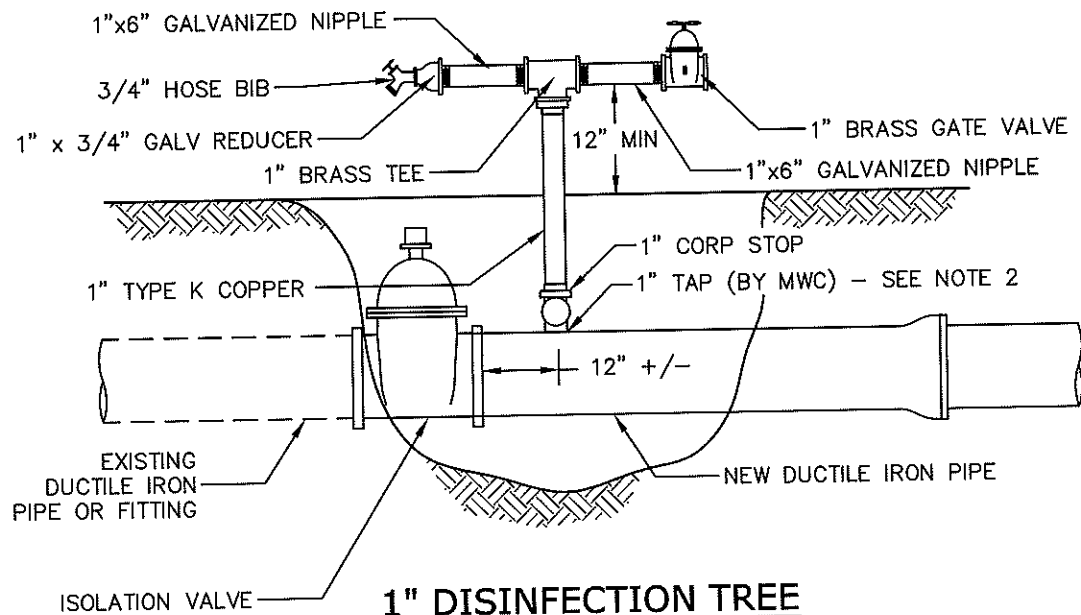

1" DISINFECTION TREE

NTS

NOTES:

1. AT A MINIMUM, RESTRAIN THE LAST THREE FULL PIPE LENGTHS FOR 4", 6", AND 8" PIPE. RESTRAIN THE LAST FIVE FULL PIPE LENGTHS FOR 12" PIPE.
2. UPON COMPLETION OF REQUIRED TESTS AND AFTER CONFIRMATION OF SAMPLE RESULTS, CONTRACTOR TO REMOVE TREE ASSEMBLY IN PRESENCE OF MWC INSPECTOR. MWC TO PROVIDE EITHER 2" GALV OR 1" BRASS PLUG.

102.DWG
 9/22/09



REV	SAMPLE & DISINFECTION TREES
10/09	STANDARD DETAIL NO. 102

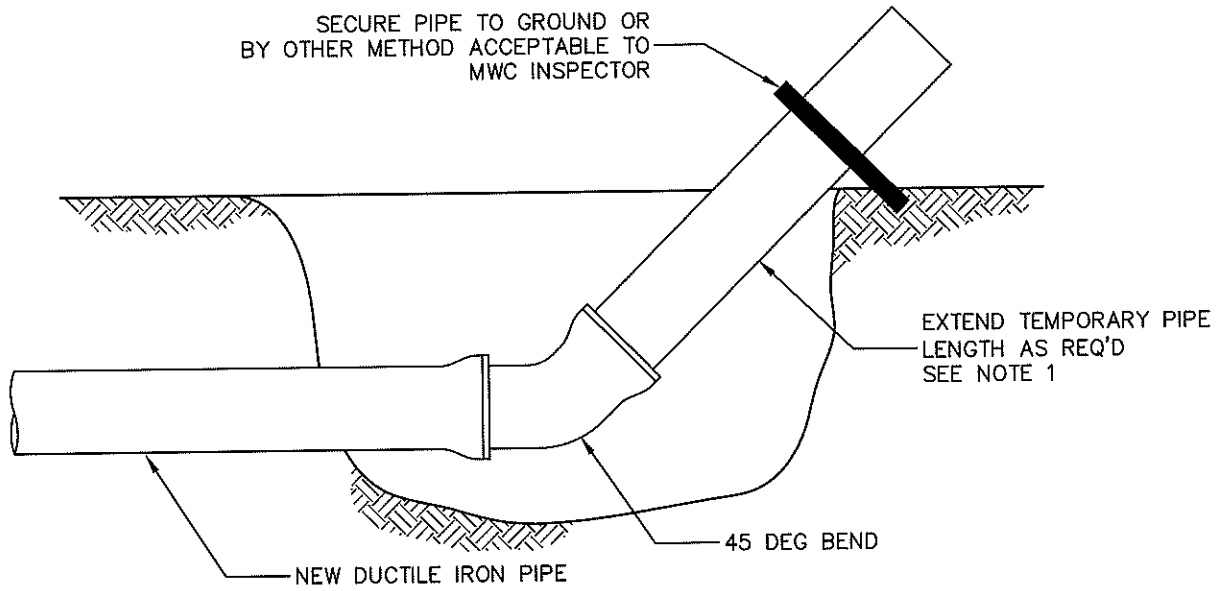

NOTES:

1. TEMPORARY PIPE SHALL BE SAME SIZE AS PIPE BEING FLUSHED FOR 4"-12" SIZES. FOR PIPES LARGER THAN 12", CONSULT WITH MWC FOR TEMPORARY PIPE SIZE.
- UPON COMPLETION OF FLUSHING, CONTRACTOR TO PREVENT RE-ENTRANCE OF WATER
2. INTO PIPE.

9/22/09 103.DWG



REV	FULL SIZE FLUSH POINT
10/09	STANDARD DETAIL NO. 103

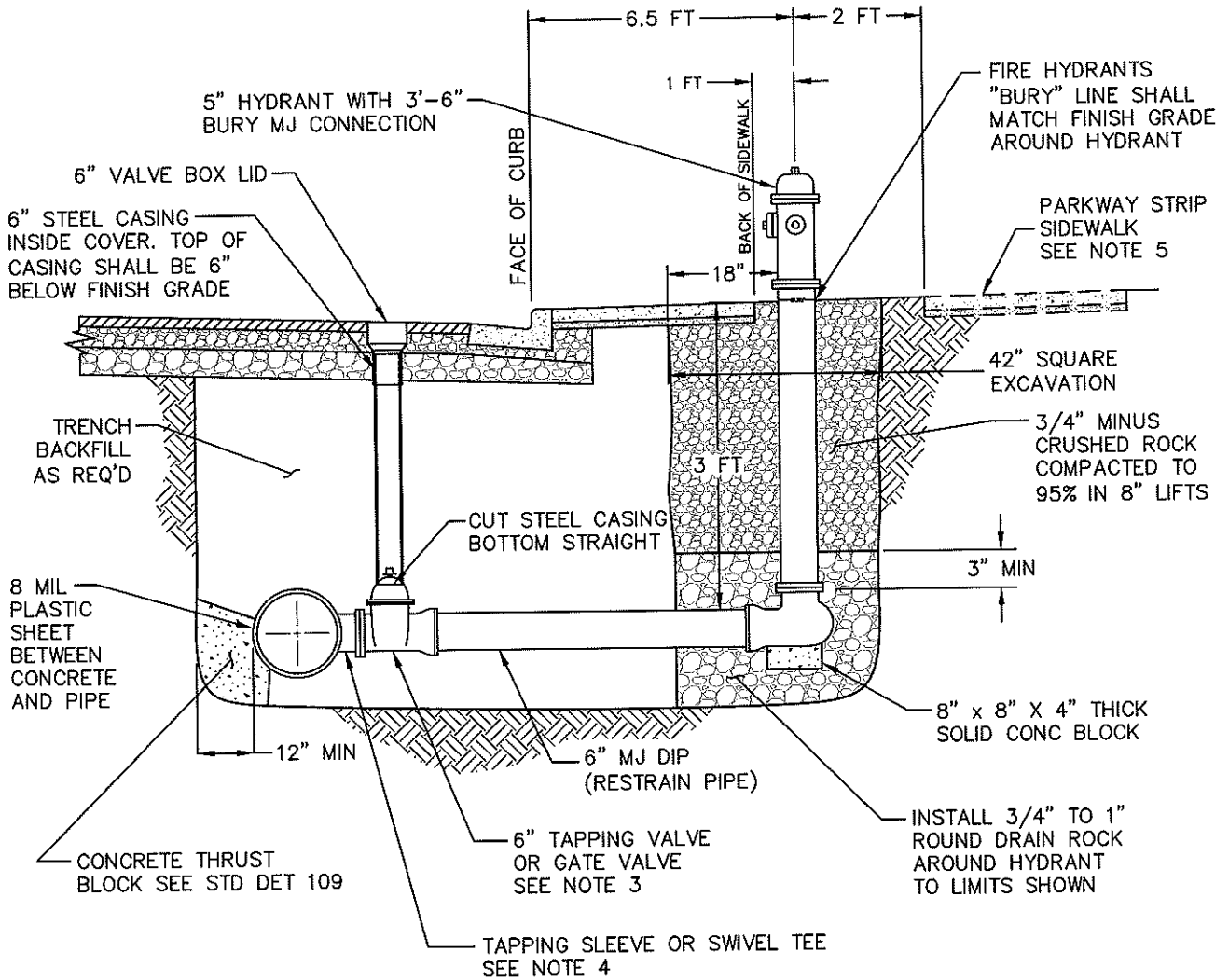

NOTES:

1. A MINIMUM OF 5 FEET OF CLEAR SPACE AROUND THE FIRE HYDRANT BARREL SHALL BE MAINTAINED AT ALL TIMES, INCLUDING INSIDE PLANTER AREAS.
2. AN OFFSET SIMILAR TO STD DETAIL 105 WILL BE REQUIRED TO USE A STANDARD 3'-6" BURY HYDRANT WHEN THE MAIN HAS GREATER THAN 3 FEET OF COVER.
3. FOR WET TAP, USE FLANGE X MJ TAPPING VALVE. FOR DRY CONNECTION, USE MJ X MJ GATE VALVE.
4. FOR WET TAP, USE TAPPING SLEEVE WITH FLANGE CONNECTION. FOR DRY CONNECTION, USE A MJ SWIVEL TEE.
5. IF PARKWAY STRIP EXISTS OR IS PLANNED, THEN FIRE HYDRANT SHALL BE LOCATED A MINIMUM OF 2 FEET FROM SIDEWALK WITHIN THE PARKWAY STRIP AREA.
6. IF BOLLARDS ARE WARRANTED, PLACE THEM 3' FROM FIRE HYDRANT, PER STD. DETAIL 112.

104.DWG

9/22/09



REV	HYDRANT INSTALLATION FOR 14" MAIN AND SMALLER
10/09	STANDARD DETAIL NO. 104

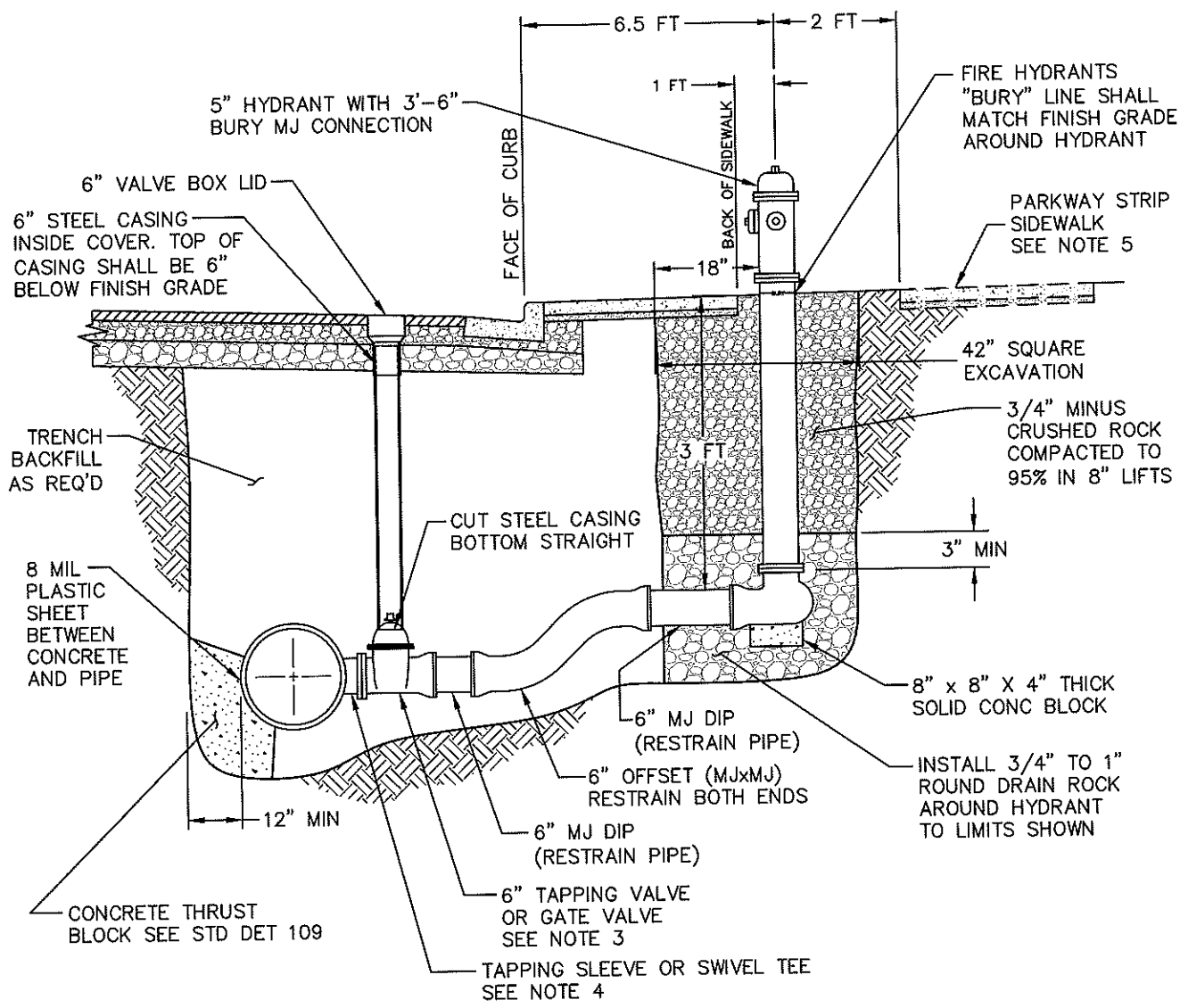

NOTES:

1. A MINIMUM OF 5 FEET OF CLEAR SPACE AROUND THE FIRE HYDRANT BARREL SHALL BE MAINTAINED AT ALL TIMES, INCLUDING INSIDE PLANTER AREAS.
2. AN OFFSET SIMILAR TO STD DETAIL 105 WILL BE REQUIRED TO USE A STANDARD 3'-6" BURY HYDRANT WHEN THE MAIN HAS GREATER THAN 3 FEET OF COVER.
3. FOR WET TAP, USE FLANGE x MJ TAPPING VALVE. FOR DRY CONNECTION, USE MJ X MJ GATE VALVE.
4. FOR WET TAP, USE TAPPING SLEEVE WITH FLANGE CONNECTION. FOR DRY CONNECTION, USE A MJ SWIVEL TEE.
5. IF PARKWAY STRIP EXISTS OR IS PLANNED, THEN FIRE HYDRANT SHALL BE LOCATED A MINIMUM OF 2 FEET FROM SIDEWALK WITHIN THE PARKWAY STRIP AREA.
6. IF BOLLARDS ARE WARRANTED, PLACE THEM 3' FROM FIRE HYDRANT, PER STD. DETAIL 112.

105.DWG
9/22/09



REV	HYDRANT INSTALLATION FOR 16" MAIN AND LARGER
10/09	STANDARD DETAIL NO. 105

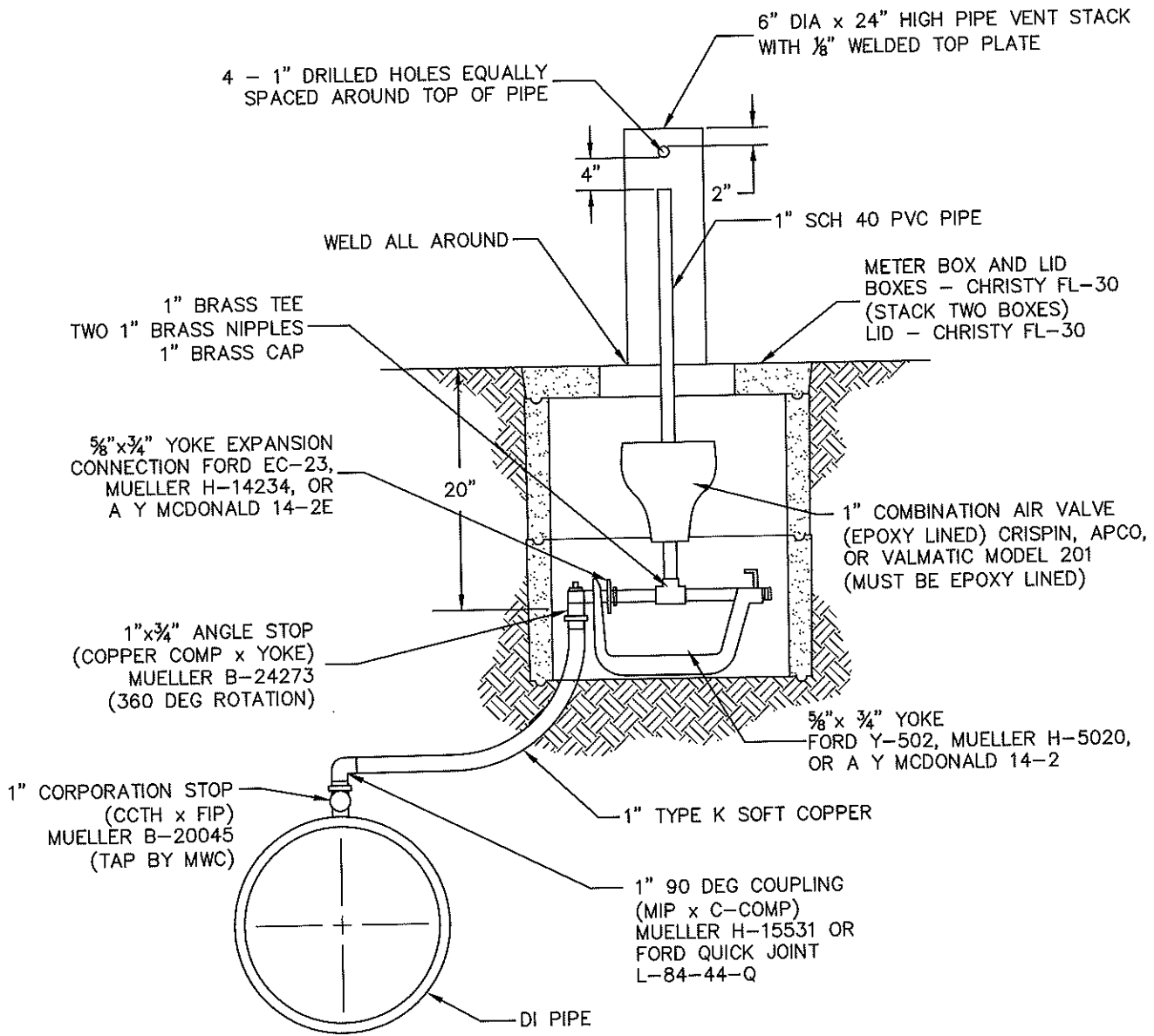

1" COPPER PIPE SHALL ALWAYS BE INSTALLED WITH GRADE RISING TOWARD THE ANGLE STOP FROM THE CORP STOP.

ALL COPPER PIPE SHALL HAVE A MINIMUM OF 6" OF SAND SURROUNDING IT.

9/22/09 106.DWG



REV	1" AIR VALVE
10/09	STANDARD DETAIL NO. 106

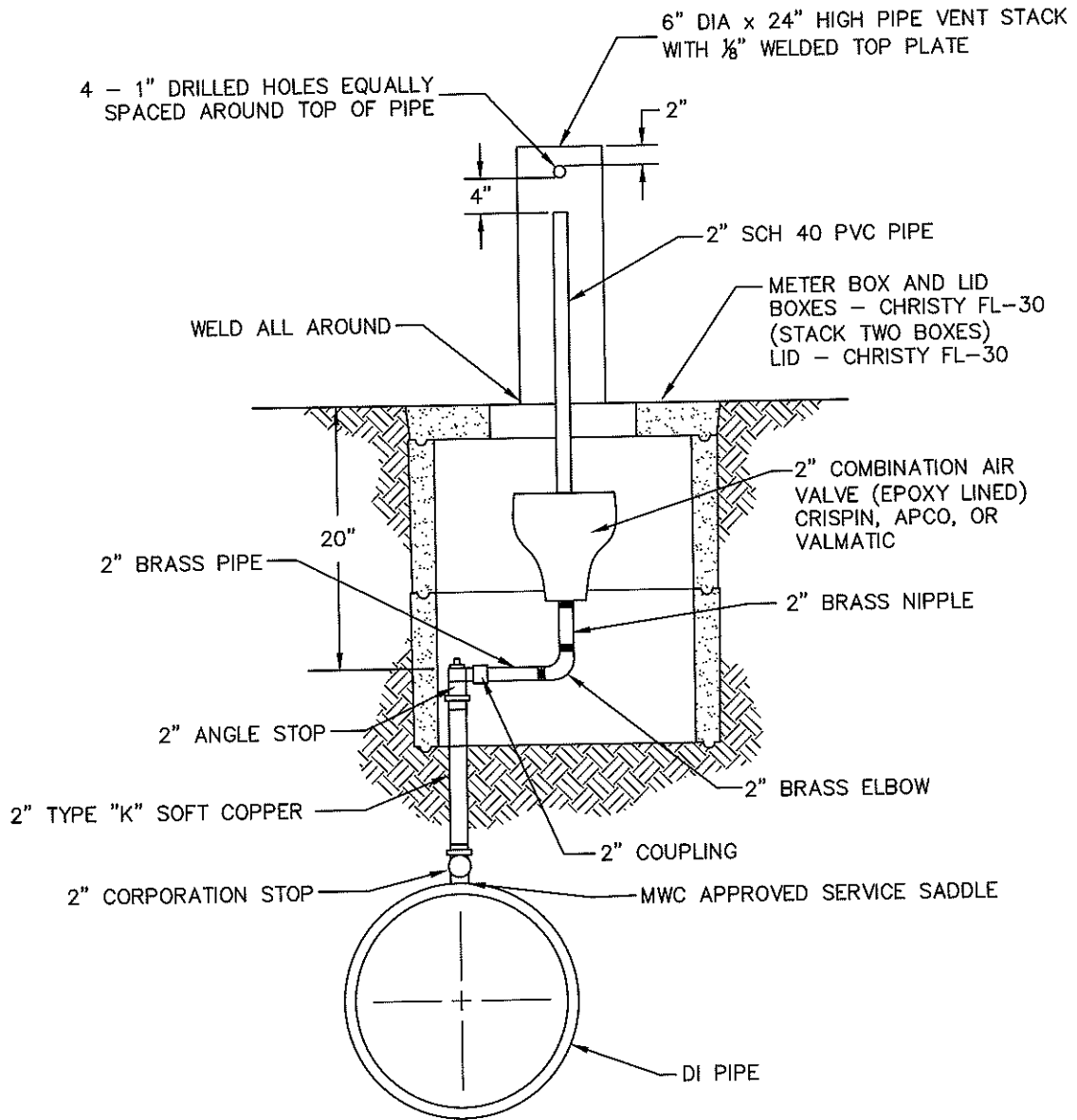

ALL COPPER PIPE SHALL HAVE A MINIMUM OF 6" OF SAND SURROUNDING IT.

107.DWG
9/22/09



REV	2" AIR VALVE
10/09	STANDARD DETAIL NO. 107

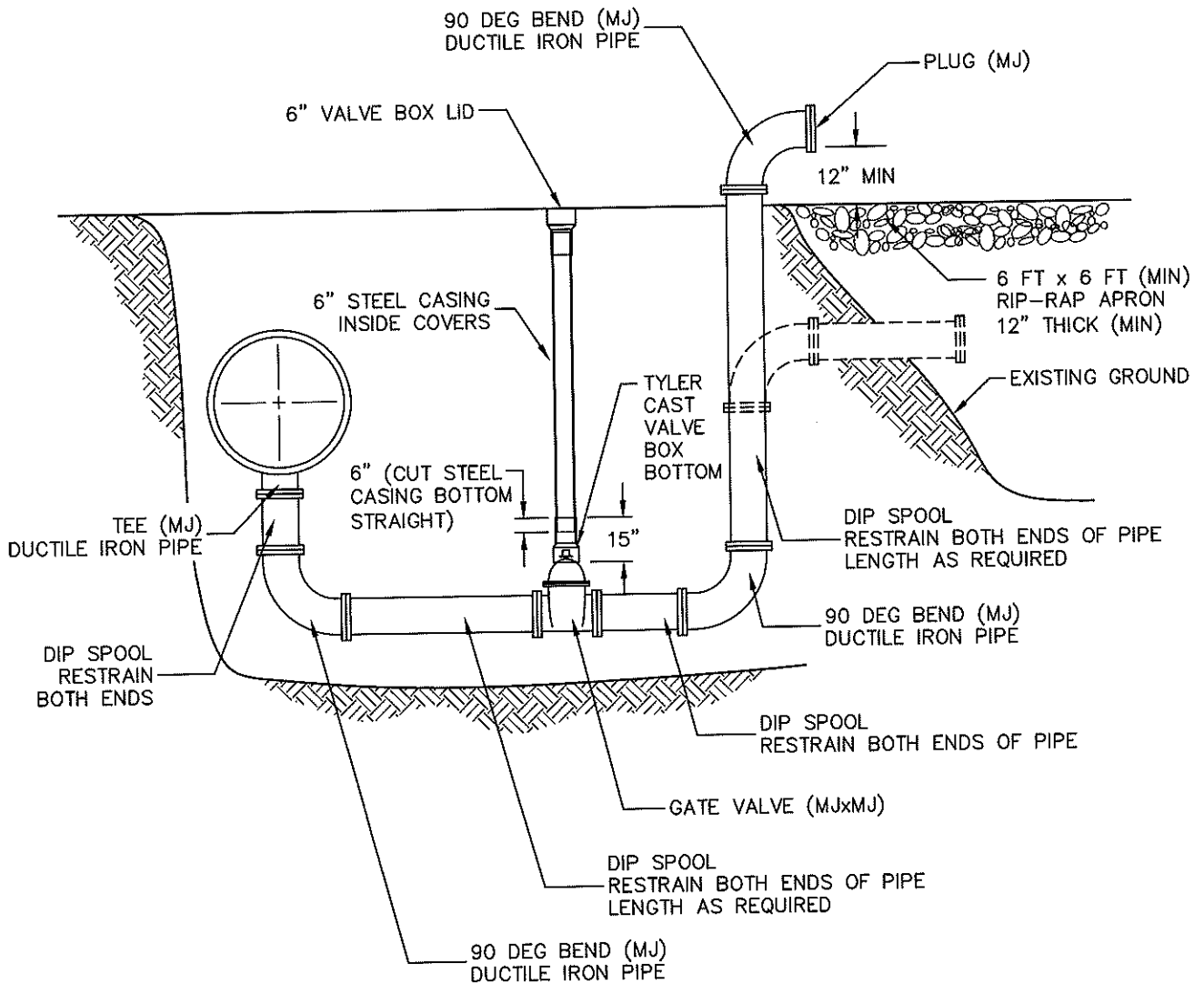

9/22/09 108.DWG



REV	MAINLINE BLOWOFF ASSEMBLY
10/09	STANDARD DETAIL NO. 108

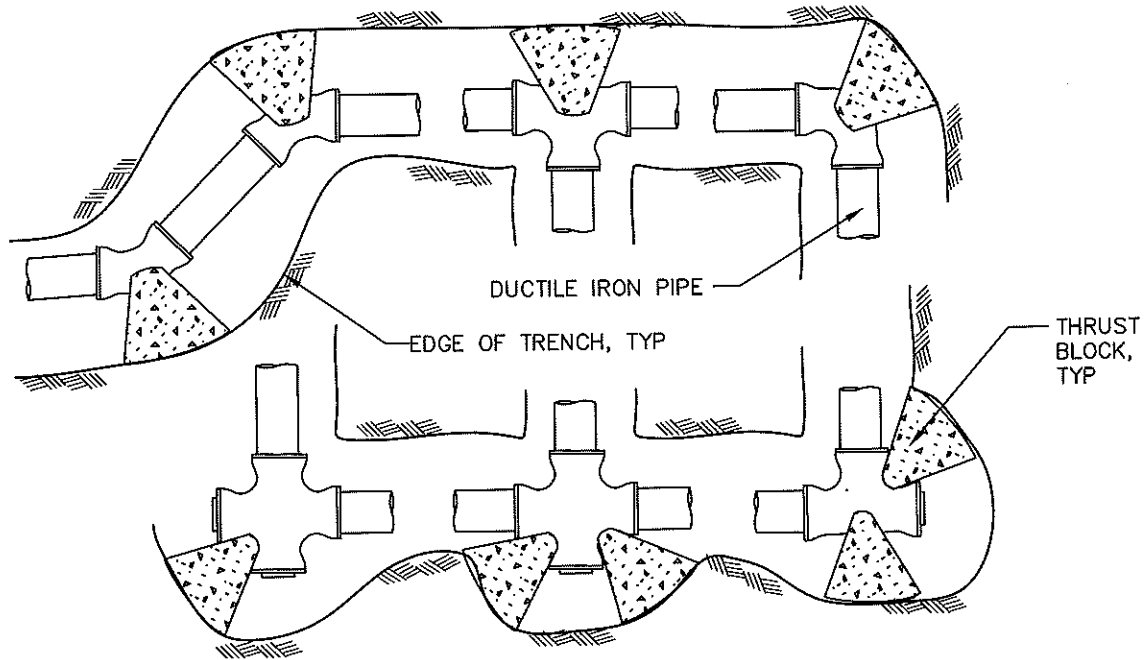

THRUST BLOCK SIZING TABLE

PIPE SIZE (INCHES)	<u>90° BEND</u>		<u>45°, 22.5°, 11.25° BEND</u>		<u>VALVES, TEES, DEAD ENDS</u>	
	<u># THRUST</u>	<u>BEARING AREA</u>	<u># THRUST</u>	<u>BEARING AREA</u>	<u># THRUST</u>	<u>BEARING AREA</u>
4	2700	2.0	1650	1.5	1950	1.5
6	6000	4.0	3450	2.5	4350	3.0
8	10800	7.5	6150	4.5	7650	5.5
12	24000	16.0	13650	9.5	16950	11.5

NOTE:
 THRUST CALCULATIONS ARE BASED ON TEST PRESSURE OF 150 PSI AND A SOIL BEARING CAPACITY OF 1500 PSF. DESIGNER IS CAUTIONED TO ENSURE THE BEARING CAPACITY OF THE SOIL IS AT LEAST 1500 PSF.

NOTES:

1. THE BEARING AREA SHOWN IN THE TABLE ARE MINIMUM VALUES.
2. ALL THRUST BLOCKS BEARING AREAS SHALL BE POURED AGAINST UNDISTURBED EARTH.
3. THE THRUST BLOCK THICKNESS SHALL BE A MINIMUM OF 12" OR TWICE THE PIPE DIAMETER, WHICHEVER IS GREATER.
4. AN 8 MIL SHEET OF PLASTIC SHALL BE WRAPPED AROUND PIPE AND FITTINGS WHEREVER PIPE WILL COME IN CONTACT WITH CONCRETE.
5. ENSURE ALL BOLTS ARE EXPOSED AND NOT COVERED WITH CONCRETE.
6. ALL CONCRETE SHALL BE 3,300 PSI MINIMUM.



REV	THRUST BLOCKS
10/09	STANDARD DETAIL NO. 109

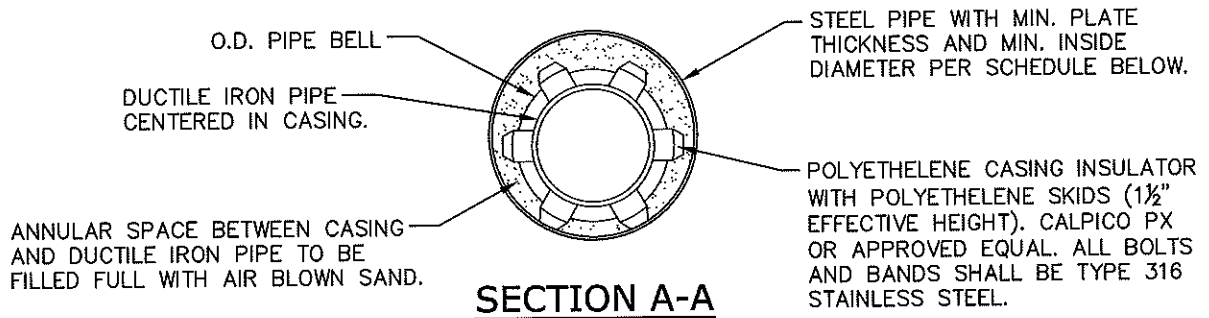
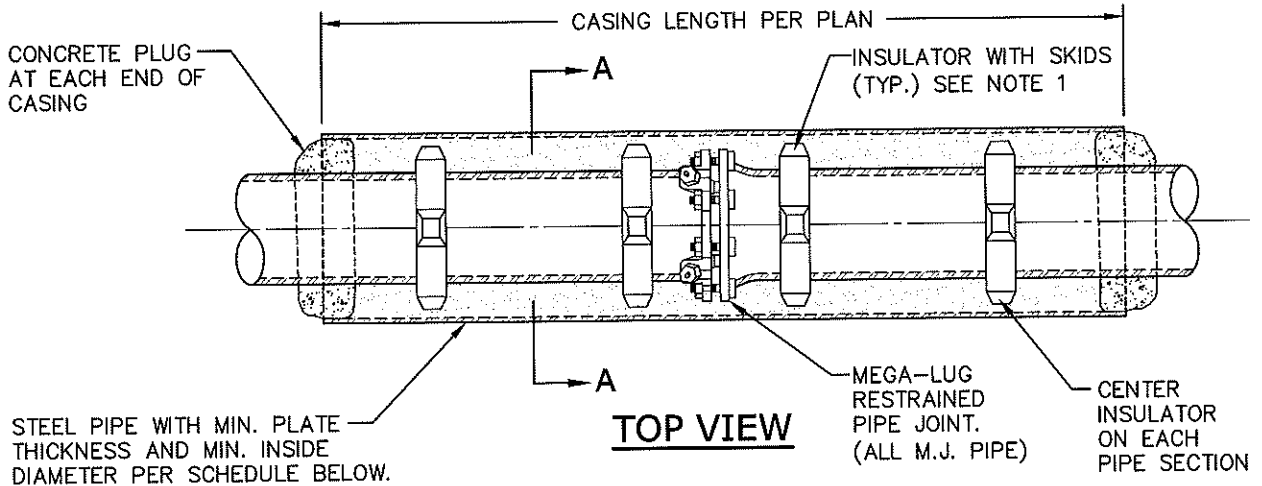

NOTES:

1. SPACING BETWEEN THE CASING INSULATORS SHALL BE PER THE MANUFACTURERS RECOMMENDATIONS, EXCEPT THAT THERE SHALL BE AT LEAST 3 CASING INSULATORS PER PIPE SECTION, ONE 12" FROM EACH JOINT AND ONE CENTERED ON THE PIPE SECTION. ADDITIONALLY, ONE INSULATOR SHALL BE INSTALLED 12" FROM EACH END OF CASING.
2. BOTH ENDS OF THE CASING BETWEEN THE CASING AND THE CARRIER PIPE MUST BE SEALED WATERTIGHT USING CONCRETE.
3. ALL STEEL CASING PIPE JOINTS SHALL BE WELDED FULL CIRCUMFERENCE.
4. SIZE AND THICKNESS OF CASING SHALL BE AS SHOWN IN SCHEDULE BELOW.
5. THE STEEL CASING SHALL BE LINED AND COATED WITH HOT APPLIED COAL TAR ENAMEL OR EQUAL.
6. RESTRAINED JOINT PIPE SHALL EXTEND BEYOND BOTH ENDS OF THE CASING FOR ONE FULL LENGTH OF PIPE.

SCHEDULE OF STEEL CASING FOR DUCTILE IRON PIPELINES

CARRIER PIPE NOMINAL SIZE (INCHES)	CASING WALL THICKNESS (INCH)	MINIMUM CASING O.D. (INCHES)
8	3/8	20
10	3/8	22
12	3/8	24
16	1/2	30
18	1/2	32
20	1/2	34
24	1/2	42
30	5/8	48

110.DWG
9/22/08



REV	CASING DETAIL
10/09	STANDARD DETAIL NO. 110

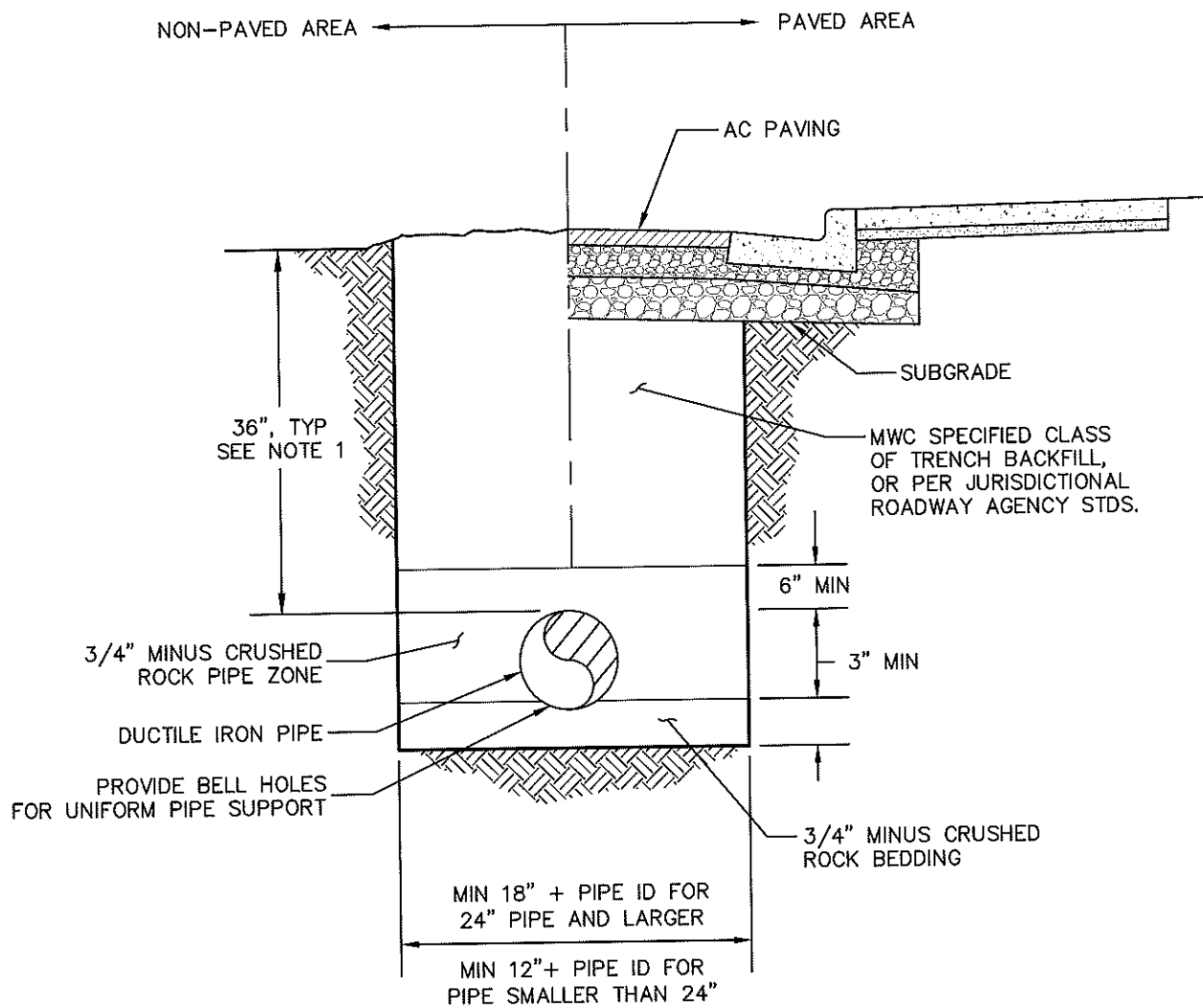

NOTES:

- COVER OVER PIPE MAY VARY FROM 36" MIN TO 42" MAX UPON APPROVAL FROM MWC.

111.DWG
9/22/09



REV	TYPICAL TRENCH DETAIL
10/09	STANDARD DETAIL NO. 111

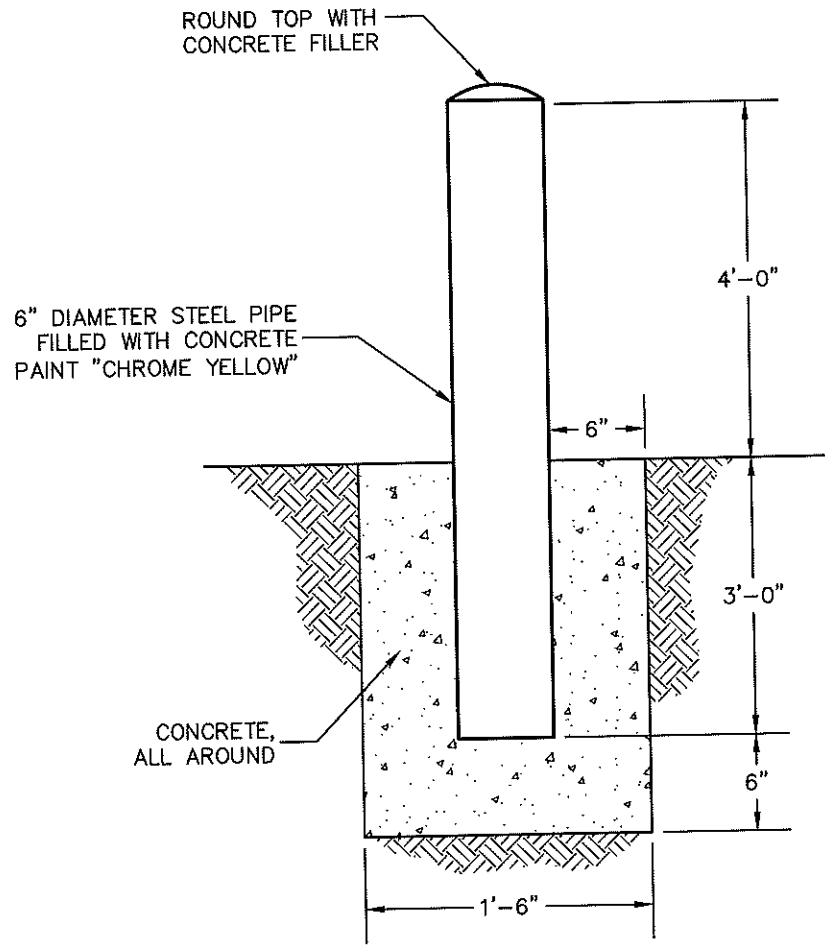
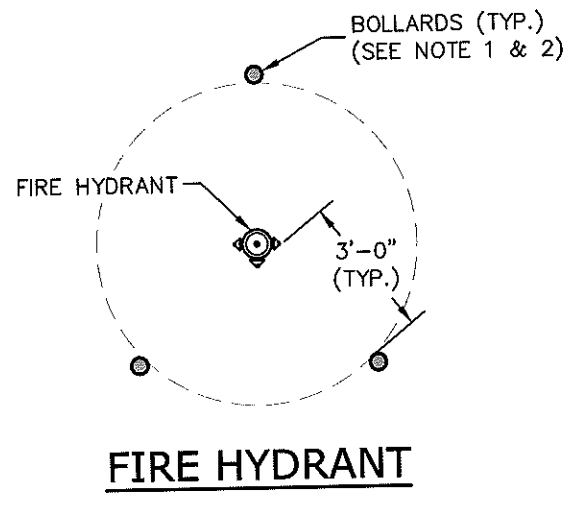
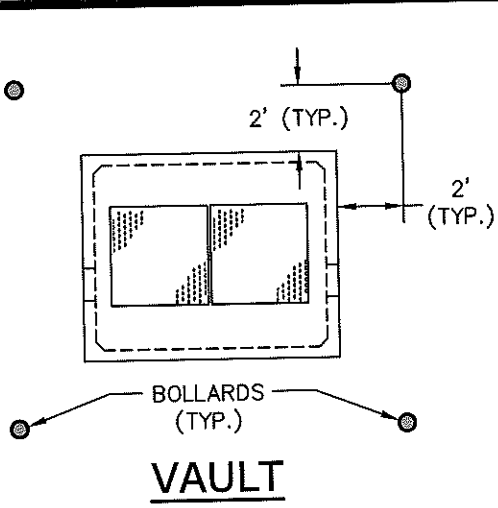

NOTES:

1. FINAL APPROVAL OF QUANTITY AND LOCATION OF BOLLARDS AT DISCRETION OF MWC.
2. IF HYDRANT IS LOCATED IN LANDSCAPED, CURBED PLANTER WITH A MINIMUM OF 5' FROM CURB FACE TO HYDRANT IN EACH DIRECTION, THEN BOLLARDS ARE NOT REQUIRED.

112.DWG
9/22/09



REV	BOLLARD DETAIL
10/09	STANDARD DETAIL NO. 112

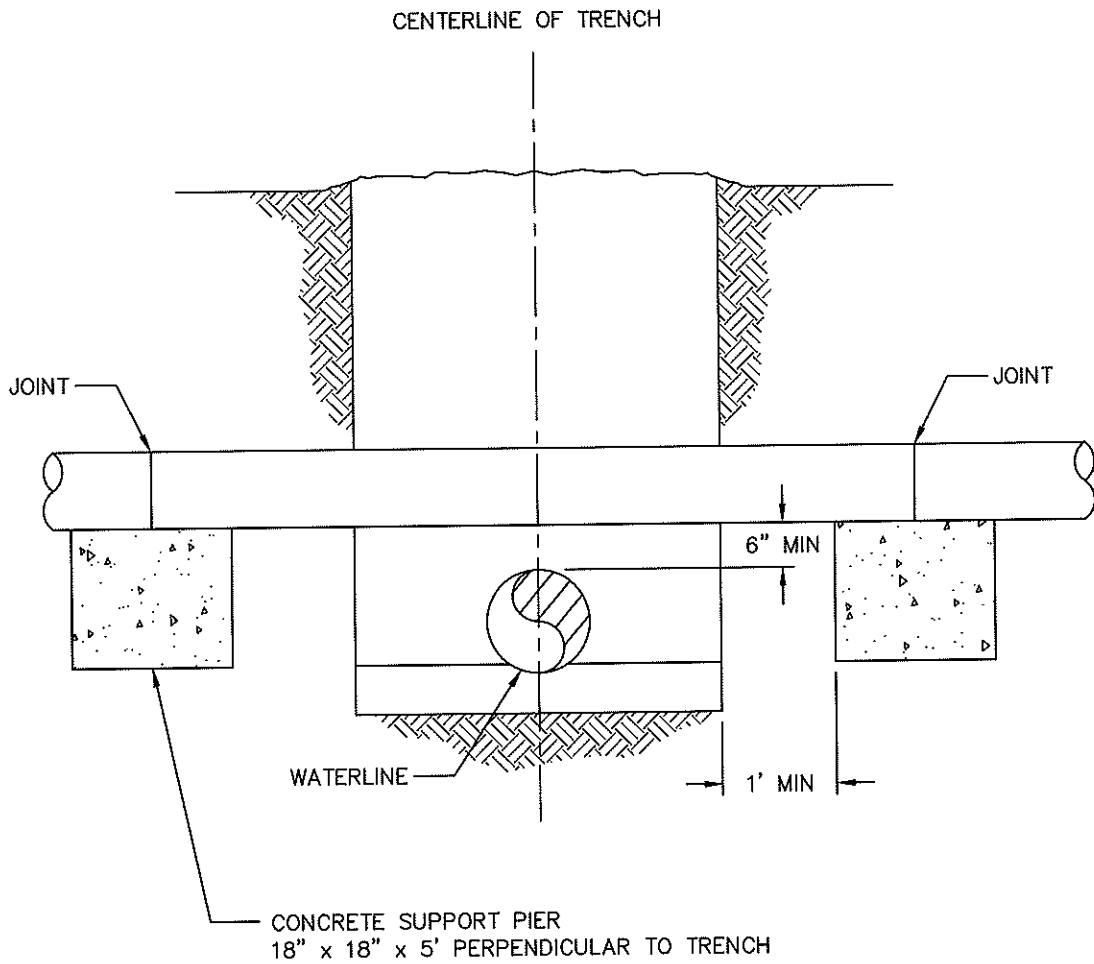

NOTES:

1. SUPPORT PIERS ARE REQUIRED FOR 18" AND LARGER PIPE CROSSINGS.

9/22/09 113.DWG



REV	PIPE SUPPORT PIER DETAIL
10/09	STANDARD DETAIL NO. 113

DUCTILE IRON POLYWRAP ENCASEMENT

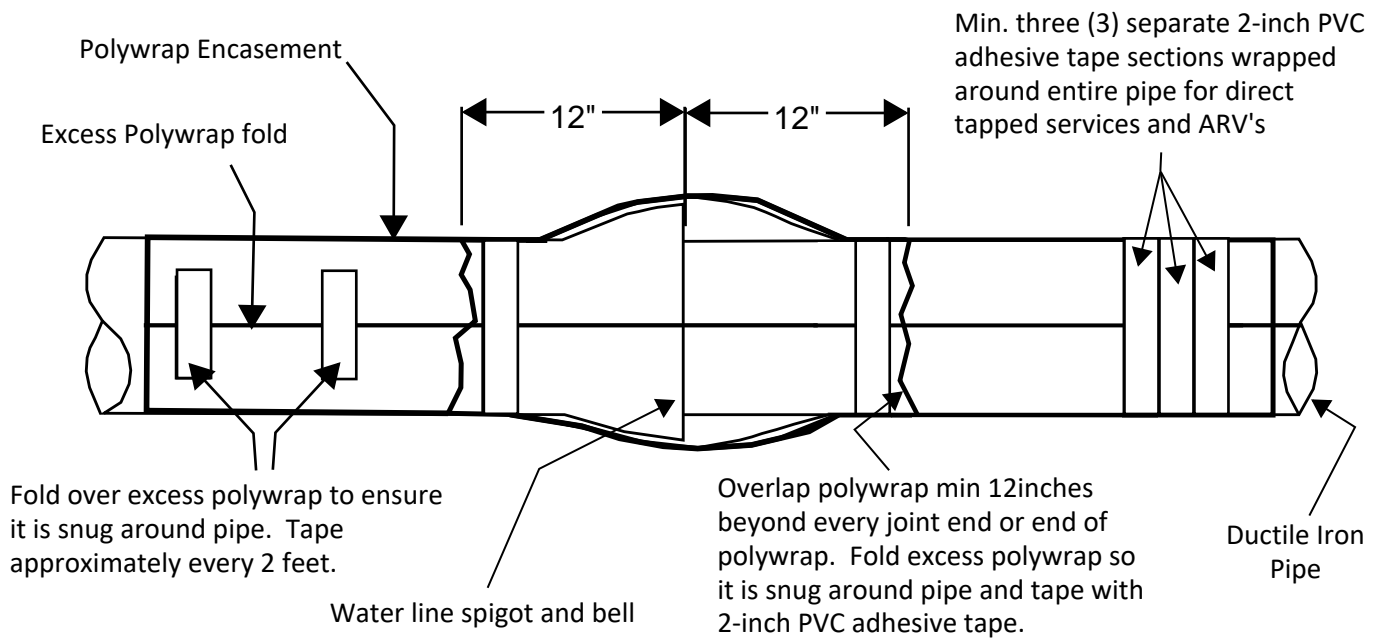

COPPER SERVICE LINE POLYWRAP ENCASEMENT

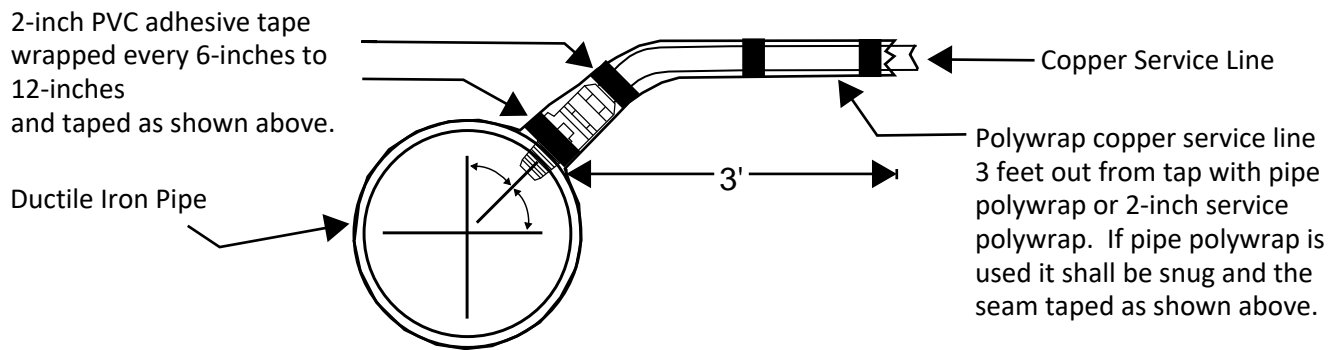

NOTES:

1. Polywrap shall conform to the requirements of ANSI/AWWA C105/A21.5 ASTM A674.
2. For correct sizing of polywrap refer to Figure 1 in the Section IV Standard Specification for Materials and Installation, Section IV STANDARD SPECIFICATION FOR POLYETHYLENE ENCASEMENT.
3. Reference DUCTILE IRON PIPE RESEARCH ASSOCIATION (DIPRA) installation guide for further installation notes and instructions.



MEDFORD WATER

REV	POLYETHYLENE ENCASEMENT (POLYWRAP) INSTALLATION
6/13/23	STANDARD DETAIL NO. 114

APPENDIXES

APPENDIX A

*Leave a blank area at least 2" x 3"
on first page for Jackson County
Recorder's label*

**SAMPLE
EASEMENT
(INDIVIDUAL)**

_____, GRANTOR, grants to the CITY OF MEDFORD, by and through its Board of Water Commissioners, Grantee, a perpetual easement for the installation and maintenance of water mains and water facilities in the following location:

A strip of land ____ feet in width and lying five feet on each side of the following described line:

[enter description here or attach separate page as Exhibit "A"]

Said easement is for the purpose of constructing, reconstructing, maintaining, using, operating and repairing pipeline facilities of the municipal water system of grantee together with the right to make such excavation therein as grantee may require and deem convenient for the installation, repair or maintenance of such facilities; including such reasonable right of ingress and egress to and from such easement as may be necessary to carry out its purposes. No other facility shall be placed within five (5) feet of the water main when running parallel to or within six (6) inches when crossing perpendicular to the water main except sanitary sewer, which is ten feet and eight inches correspondingly.

Grantor reserves the right to use and possess such land within the easement as shall not interfere with Grantee's use thereof for the purposes above set forth, but grantor shall not cause any buildings or permanent structures to be constructed over any part of the easement without grantee's consent.

This easement touches and concerns the land and is intended to bind grantor, its heirs, successors and assigns.

DATED this ____ day of _____, _____.

(Print name)

(Print name)

(Signature)

(Signature)

STATE OF OREGON)
) ss.
County of _____)

This instrument was acknowledged before me on the _____ day of _____,

by _____

Notary Public for Oregon

My Commission Expires: _____

APPENDIX B

Leave a blank area at least 2" x 3"
on first page for Jackson County
Recorder's label

**SAMPLE
EASEMENT
(CORPORATION)**

_____, GRANTOR, grants to the CITY OF MEDFORD, by and through its Board of Water Commissioners, GRANTEE, a perpetual easement for the installation and maintenance of water mains and water facilities in the following location:

A strip of land _____ feet in width and lying _____ feet on each side of the following described line:

[enter description here or attach separate page as Exhibit "A"]

Said easement is for the purpose of constructing, reconstructing, maintaining, using, operating and repairing pipeline facilities of the municipal water system of Grantee together with the right to make such excavation therein as grantee may require and deem convenient for the installation, repair or maintenance of such facilities; including such reasonable right of ingress and egress to and from such easement as may be necessary to carry out its purposes. No other facility shall be placed within five (5) feet of the water main when running parallel to or within six (6) inches when crossing perpendicular to the water main except sanitary sewer, which is ten feet and eight inches correspondingly.

Grantor reserves the right to use and possess such land within the easement as shall not interfere with Grantee's use thereof for the purposes above set forth, but Grantor shall not cause any buildings or permanent structures to be constructed over any part of the easement without Grantee's consent.

This easement touches and concerns the land and is intended to bind grantor, its heirs, successors and assigns.

DATED this _____ day of _____, _____.

(Name of organization; corporation, etc.)

By _____
(Print name(s) and title)

(Signature)

(Signature)

STATE OF OREGON) ss.
County of Jackson)

This instrument was acknowledged before me on the _____, day of _____

_____, by _____,

as _____
(type of authority, e.g., officer, trustee, etc.)

for _____
(name of party {i.e., corporation or company} on behalf of whom instrument was executed)

Notary Public for Oregon
My Commission Expires: _____

Mail Tax Statements To:
(No Change)

Leave a blank area at least 2" x 3" on first page for Jackson County Recorder's label

APPENDIX C

**SAMPLE
QUITCLAIM DEED**

_____ ("Grantor"), does hereby remise, release and forever quitclaim to _____ ("Grantee"), all of its rights, title and interest in and to the hereinafter described real property in the County of Jackson, City of Medford, State of Oregon.

That portion of the real property subject to the easement granted _____, pursuant to that certain Easement from the Grantee to the Grantor, recorded on _____, as Document No. _____ of the Official Records of the County Clerk's Office of Jackson County, Oregon, legally described on Exhibit "A" attached hereto and shown on the map attached as Exhibit "B."

_____ hereby agrees that the Water Easement is hereby terminated, released and discharged with respect to the Released Easement Area and shall remain in effect as to the remaining portions of the property in the Water Easement.

Before signing or accepting this instrument, the person transferring fee title should inquire about the person's rights, if any, under ORS 197.352. This instrument does not allow use of the property described in this instrument in violation of applicable land use laws and regulations. Before signing or accepting this instrument, the person acquiring fee title to the property should check with the appropriate city or county planning department to verify approved uses, to determine any limits on lawsuits against farming or forest practices as defined in ORS 30.930 and to inquire about the rights of neighboring property owners, if any, under ORS 197.352.

The consideration for this conveyance: good and valuable (\$ 0.00).

IN WITNESS WHEREOF, said Grantor has executed this Quitclaim Deed this ____ day of _____, 20__.

By (Printed Name): _____

Signature: _____

Its: _____

STATE OF OREGON) ss
County of Jackson)

This instrument was acknowledged before me on the ____ day of _____, 20__, by _____, as _____, and that said instrument is the free act and deed of such _____.

BY: _____
Notary Public for Oregon

My Commission Expires: _____

APPENDIX D

SAMPLE – EXHIBIT 'A'

WATER LINE EASEMENT

A strip of land 10-feet in width lying 5 feet on each side of the following described centerline.

Commencing at the East quarter corner of Section 19 Township 37 South, Range 1 West of the Willamette Meridian in the City of Medford, Jackson County, Oregon; thence along the Easterly boundary of said Section 19, North 0° 10' 00" West, 421.02 feet; thence West, 803.52 feet to the Southeast corner of tract described in Inst. No. 97-36361 of the Official Records of said county; thence along the Easterly boundary of said tract, North 0° 10' 15" West (record = North 0° 10' 00" West), 258.07 feet to THE TRUE POINT OF BEGINNING; thence leaving said tract boundary, North 89° 15' 19" East, 76.87 feet; thence North 1° 06' 39" East, 163.51 feet; thence North 11° 51' 57" East, 135.90 feet; thence North 0° 20' 31" West, 28.97 feet to Point "A"; thence North 0° 22' 32" West, 153.90 feet; thence North 36° 15' 24" West, 52.98 feet and there terminating on the Southerly right-of-way line of McAndrews Road.

The sidelines of said 10' wide strip are to be lengthened or shortened to terminate on the Easterly boundary of tract described in Instrument No. 97-36361 of the Official Records of Jackson County, Oregon, and the Southerly right-of-way line of McAndrews Road.

ALSO a strip of land 15 feet in width lying 7.5 feet on each side of the following described centerline: Beginning at the hereinbefore described point "A"; thence East, 41.29 feet and there terminating.

APPENDIX E

SAMPLE

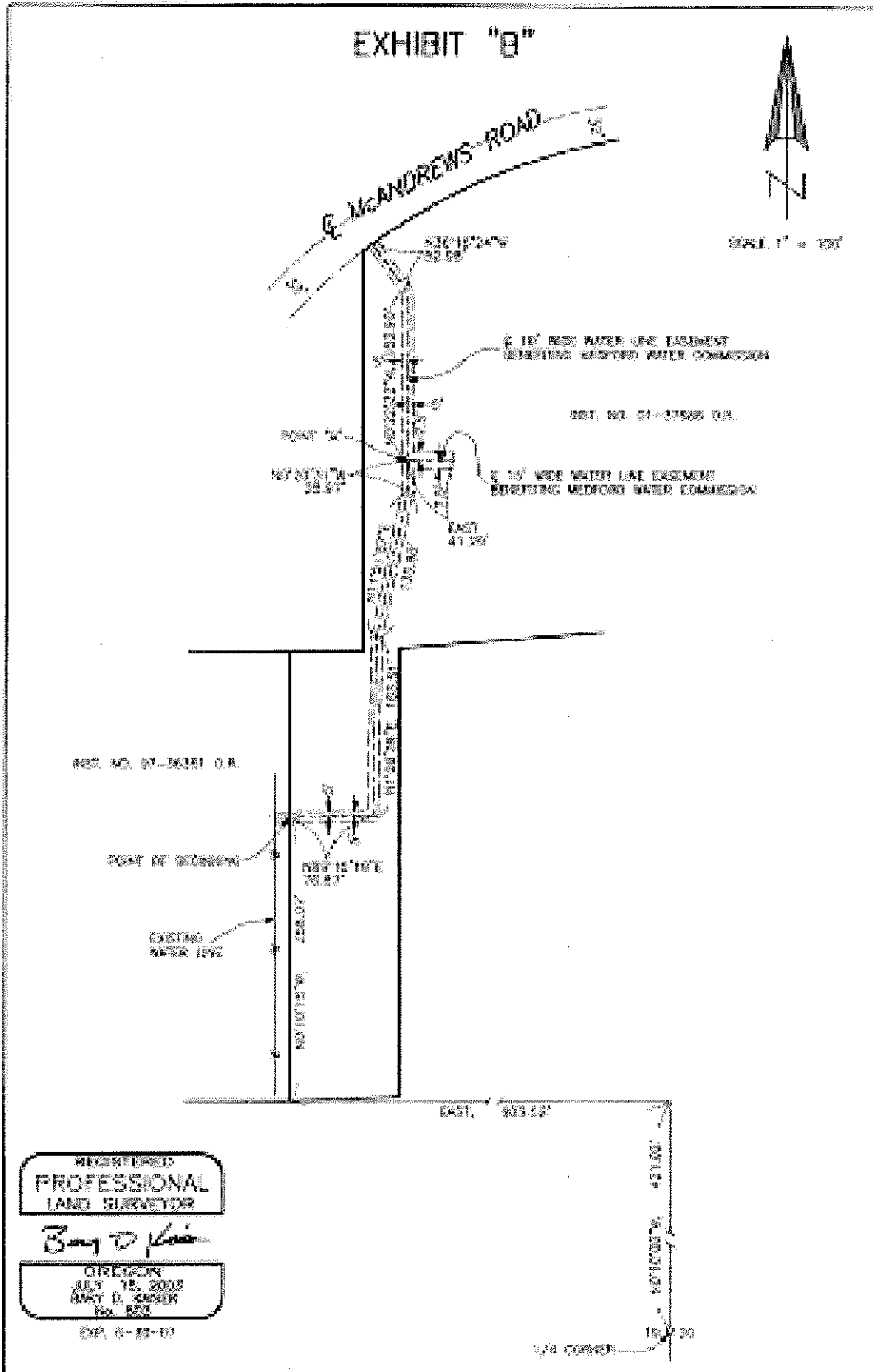

APPENDIX F
SAMPLE
DEDICATION AND DECLARATION OF WATER SYSTEM FACILITIES FORM



REMIT TO: Medford Water Commission, 200 S. Ivy St. – Room 177, Medford OR 97501

PROJECT NO. XXXXX
CIPXX-XX

DEDICATION AND DECLARATION OF ACCEPTANCE OF
WATER SYSTEM FACILITIES

The water system facilities described below are hereby dedicated to public use and all rights, title and interest of the undersigned are hereby vested in the City of Medford, acting by and through its Board of Water Commissioners.

Water system facilities for [Project Name] water lines located in the vicinity of [Street Name] @ [Street Name] and described as follows:

X feet of X-inch ductile iron pipe \$ _____ (cost)
and [Number] (X) fire hydrant(s) \$ _____ (cost)
and all appurtenances including valves and fittings.

The undersigned hereby certifies that all persons due any amounts for furnishing of materials or labor or for the use of equipment for the installation of the above described facilities have been paid and that no liens have been filed and the undersigned agrees to indemnify and save harmless the city from any and all defects appearing or developing in the workmanship performed or material furnished for the water system facilities described above for a **period of one year after the date of acceptance by the City.**

Dated this _____ day of _____, 200__.

(Firm or Corporation)

(Address)

(City, State, Zip)

By _____
(Signature of person authorized to sign on behalf of above firm or corporation)

(Print Name)

State of Oregon)
) ss:
County of Jackson)

This instrument was acknowledged before me on _____, 200__, by

(Name of person whose signature appears above)

as _____ of _____
(Title of person whose name appears above) (Firm or Corporation whose name appears above)

(Signature of Notarial Officer) (Seal, if any)

I, Eric C. Johnson, Principal Engineer of the Medford Water Commission, having inspected the above-described water system facilities, do hereby find that said project has been completed substantially in accordance with the plans and specifications therefore, and based upon said finding, I hereby certify said findings and on behalf of the Medford Water Commission do hereby accept the dedication in fee contained herein, and declare such project accepted by the City of Medford acting by and through its Board of Water Commissioners.

Dated this _____ day of _____, 200__.

Eric C. Johnson, Principal Engineer

APPENDIX G

PROCEDURES CHECKLIST

- Developer submits a copy of a preliminary site plan.
- MWC provides a preliminary water line layout review.
- Developer's engineer designs water system in accordance with current MWC standards, with Plan and Profile and in engineer land scale measure units (e.g., feet).
- Developer's engineer furnishes MWC one (1) complete set of plans for checking. This set is to include a utility plan showing, if available, main utility routing (i.e., power, telephone, gas, cable T.V.), street lights, driveways, mailbox locations, transformer pads, telephone pedestals, cable T.V. closures, etc. Plans are to be done using computer-aided drafting.
- Developer's engineer, after receiving submitted plan set and a letter outlining fees and subsequent steps back from MWC, arranges a pre-design meeting in which all utilities coordinate their facilities. Engineer makes necessary corrections and submits three (3) sets of water plans, two (2) complete set of plans, and the original correction set for approval of and prior to starting the project. MWC's conversion to a Geographic Information System (GIS) requires the developer's engineer to supply coordinate data information on all waterline facilities in a form compatible with MWC's system. This system shall be a CD using the latest AUTOCAD .DWF format.
- Developer submits deposit for estimated cost of plan check work to be performed by MWC (inspection, flushing, testing, disinfection, dechlorination, sampling, air release valves, record drawings, hydrant painting) water service fees, system development charges, charges in lieu of assessment, etc.
- Developer submits all necessary easements. Easements must be in written form unless shown on a final recorded plat, in which case, a statement concerning construction and maintenance as worded in Appendix A shall be included on the plat. Water is not covered under a Public Utility Easement (P.U.E.) notation and must be stated separately.
- Developer signs a pre-development agreement acknowledging what responsibilities are required for finalization and acceptance of the water facilities.
- Developer's prequalified contractor arranges preconstruction meeting with MWC at least 48 hours prior to start of project.
- MWC returns two sets of stamped approved plans to the contractor. One set "must" be at the job site during construction.
- DEVELOPER'S SURVEYOR SETS OFFSET HUBS FOR HORIZONTAL AND VERTICAL CONTROL WITH CUT STAKES FOR GRADE ELEVATIONS. WATER LINE GRADES SHALL BE CALCULATED FOR 36" OF COVER AND NOT TAKEN FROM PROFILE AS EXACT ELEVATIONS.**
- Developer's prequalified contractor furnishes MWC with 48 hours notice prior to start construction.
- The contractor and the person installing the pipe are prequalified by MWC to install water facilities.
- Water facilities installed upon notification of the MWC 's inspector, and nothing buried or concealed until the MWC 's inspector has viewed and approved of. All uninspected lines

will be required to be uncovered in its entirety for approval and acceptance.

- Air valves installed by MWC upon payment of the standard fee and as required by MWC Standards (Standard Detail Numbers 106 and 107). Contractor is to provide excavation and backfill. Finished grade stakes for exact air valve location must be supplied by the developer's surveyor prior to their installation.
- Fire hydrants to be installed as required by MWC Standards (Standard Detail Numbers 104 and 105).
- Service connections installed for each parcel per MWC standards (Standard Detail Numbers 100A & B and 101A & B). Finished grade stakes for exact service connection location must be supplied by the developer's surveyor prior to their installation.
- New water mains pressure tested, disinfected, and dechlorinated by MWC forces and proven to be bacteriologically safe prior to placing in service. MWC's inspector will decide the acceptable procedure for testing, disinfection, and dechlorination.
- Developer's contractor notifies MWC 48 hours in advance of desired final inspection.
- Upon final inspection, finished surfacing and completion of any discrepancies, MWC furnishes the developer with the *Dedication & Declaration of Acceptance of Water System Facilities* forms.
- The developer supplies MWC a statement of actual cost of the water facilities as noted on the dedication form.
- Developer signs MWC's form for *Dedication & Declaration of Acceptance of Water System Facilities*.
- MWC accepts water system facilities and will allow metered service to parcels within the project.
- A final billing or refund prepared by MWC to close the project.
The final bill must be paid in full before all water meters as set by MWC.
- After a one-year period, MWC releases developer from responsibility. Developers should note that until this point is reached, they carry the responsibility and liability of the water facilities even though water is provided through the system by MWC. If a leak or problem occurs during this period, MWC will repair the water facilities and bill the developer. The surfacing and/or restoration of the damaged surrounding area will be the responsibility of the developer and his contractor to repair.

APPENDIX H

RESPONSIBLE PARTY

The responsible party is the person or company that is liable for all charges/fees incurred by the project. The following information must be completed prior to any work order being issued by MWC to perform any work on the project.

Print or Type all information:

Name of Project: _____

Name of Company: _____

Name of Person: _____ Date: _____

Street Address: _____

City, State and Zip code: _____

Phone Number: _____ Cell Number: _____

Fax Number: _____ Email Address: _____

All invoice and or refunds will be sent to the above party. The party signing this form must be the same as the above party (person).

Sign: _____ Date: _____